

TED(21) 1005 A & TED(21) 1005 B

Scoring Indicators

COURSE NAME: ENGINEERING GRAPHICS

COURSE CODE: 1005

QID: 2110220186 A

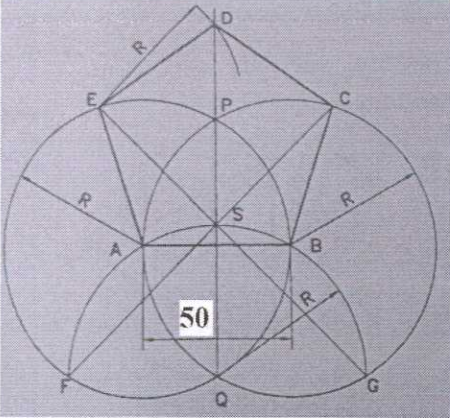
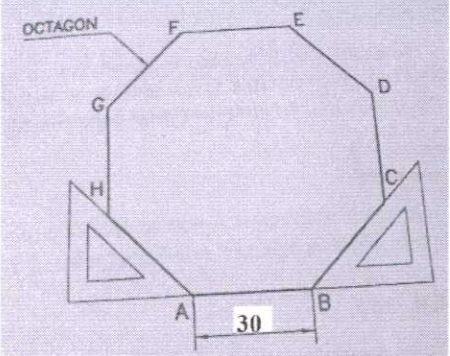
Q.No	Scoring Indicators	Split score	Sub Total
PART A			5
I.1	Visible out lines, visible edges	0.5 × 2	1
I.2	Equal to one	1	1
I.3	A straight line drawn from a point on the contour of an object to the plane on which the image of the object is obtained.	1	1
I.4	It is a pictorial orthographic projection of an object on the vertical plane of projection in which the transparent cube containing the object is tilted in such a way that its three mutually perpendicular edges make equal angles with the plane of projection.	1	1
I.5	Method of preparing engineering drawings by using computer software is called Computer Aided Design and Drafting.	1	1
PART B			40
II.1		Drg. 4 Dim. 2 Labelling. 1 Neatness. 1 (using any method)	8
II. 2		Drg. 4 Dim. 2 Labelling 1 Neatness. 1 (using any method)	8

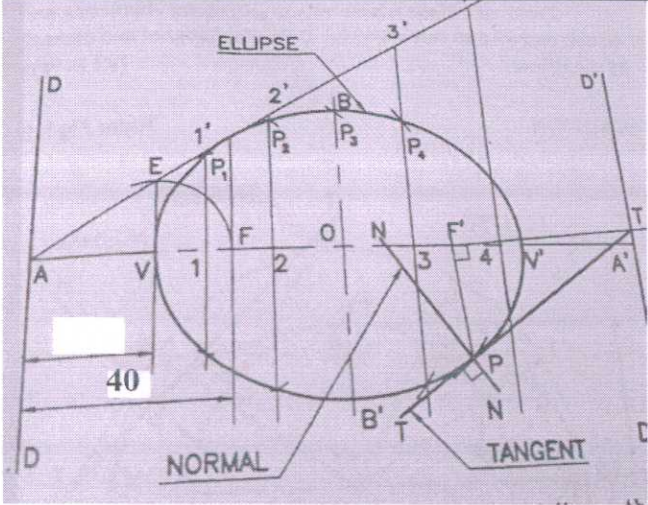
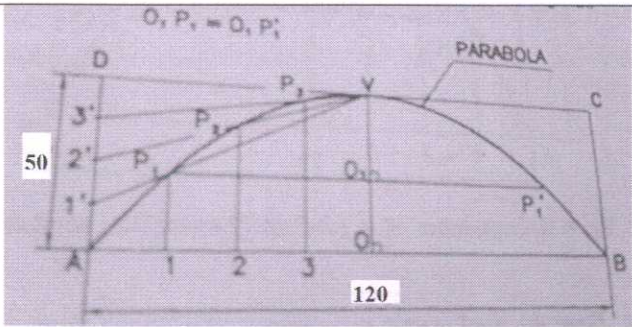
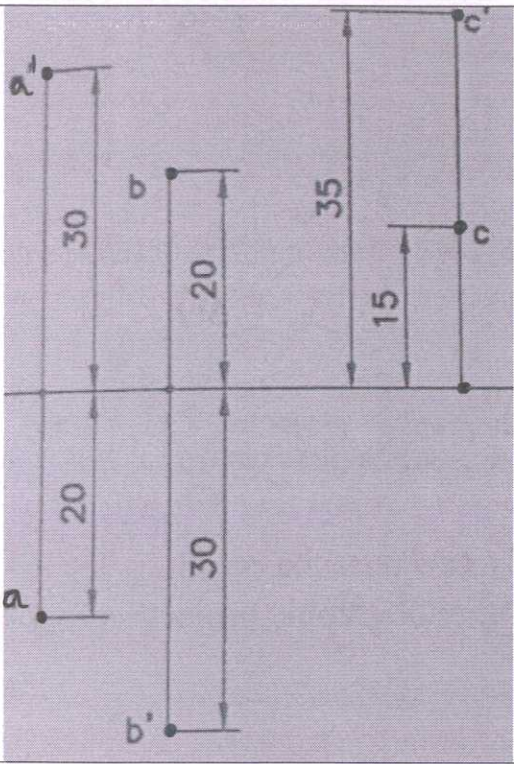
<p>II. 3</p>		<p>Drg. 6 Labelling. 1 Neatness. 1</p> <p>Normal & Tangent not required</p>	<p>8</p>
<p>II. 4</p>		<p>Drg. 4 Dim. 2 Labelling. 1 Neatness. 1</p>	<p>8</p>
<p>II. 5</p>		<p>Points 2x3 Dim 1 Neatness 1</p>	<p>8</p>

II.6

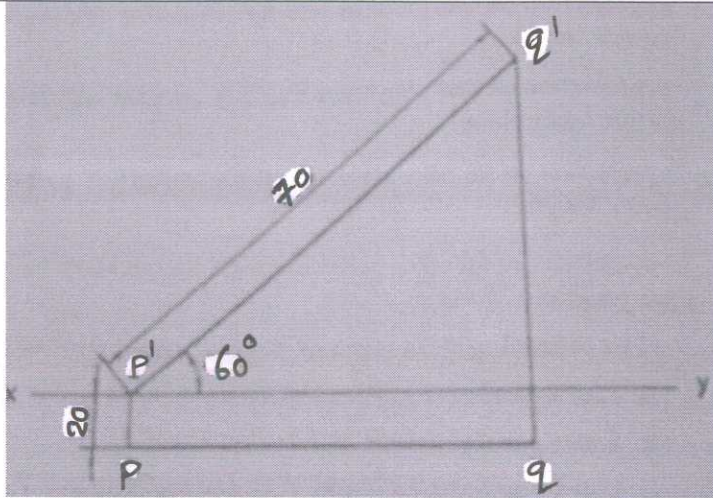

Proj 6
Dim 1
Neatness 1

8

II.7

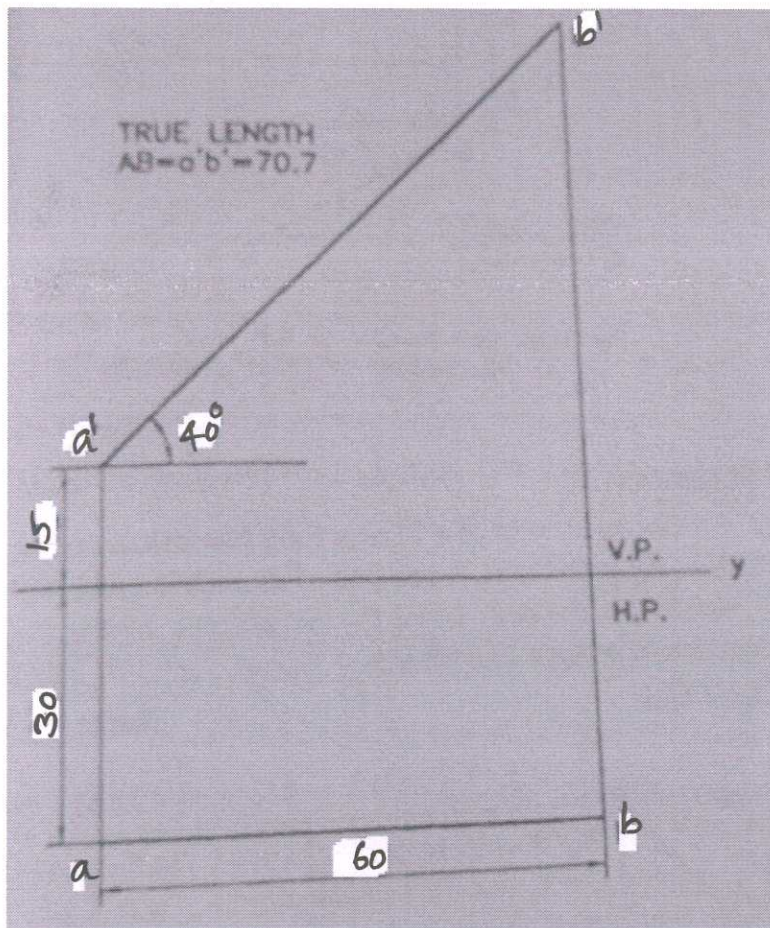

Proj 5
True length
1
Dim 1
Neatness 1

8

PART C

30

III.1

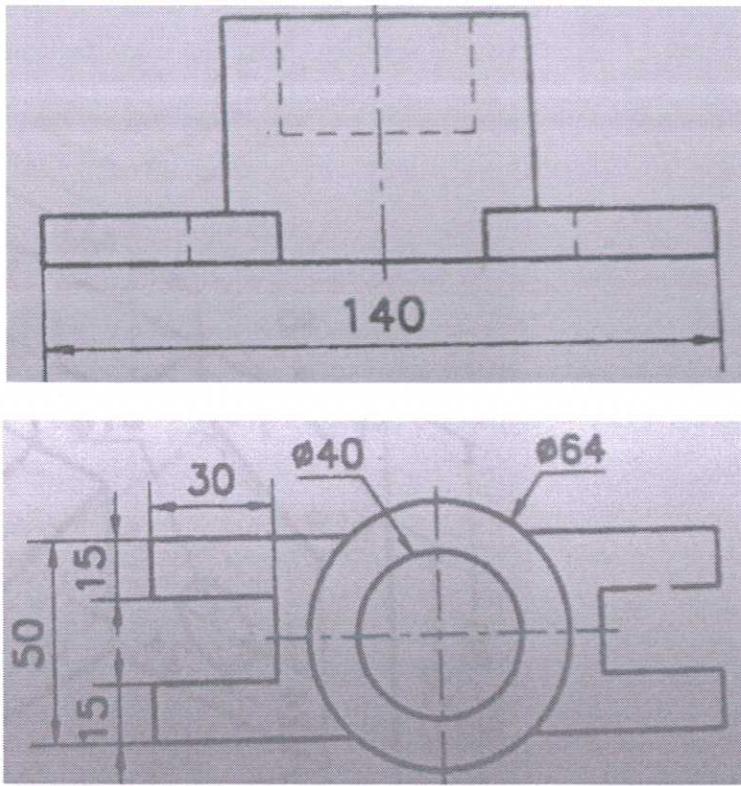

Front view 7
Top view 5
Dim 2
Neatness 1

15

III.2

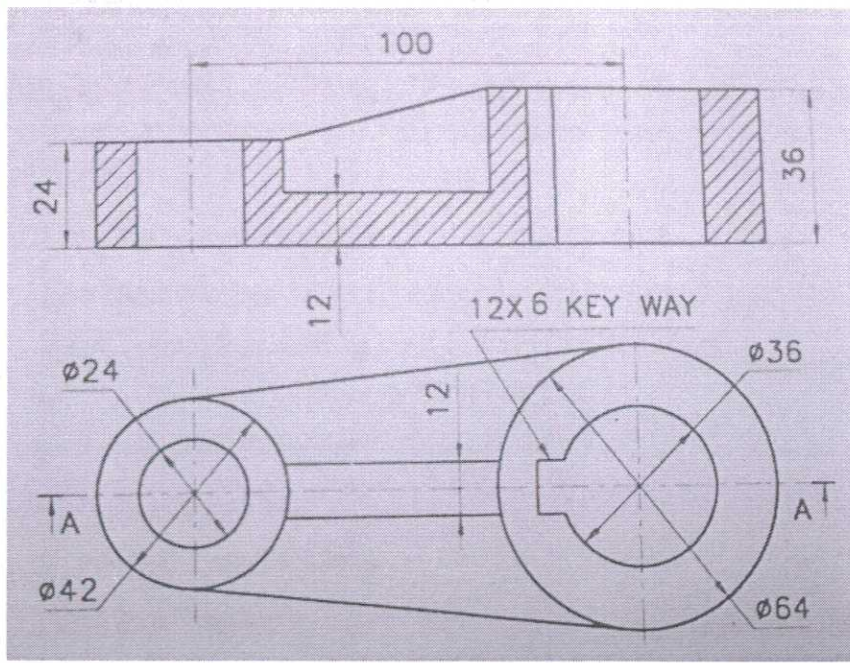

Section 7
Top view 5
Dim 2
Neatness 1

15

III.3

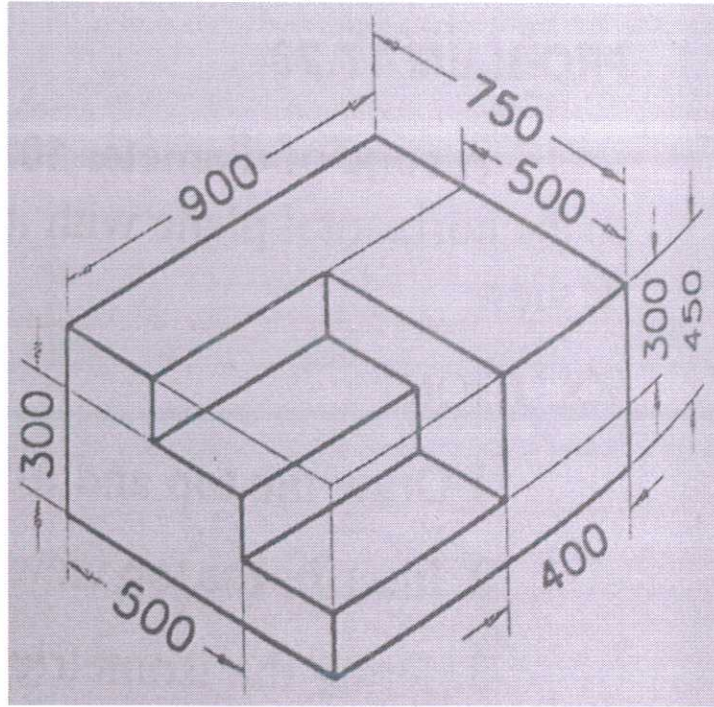

Isometric
view 10
Isometric
angle line
2
Dim 2
Neatness
1

15

Scoring Indicators
ENGINEERING GRAPHICS

1005

Q.No

Scoring Indicators

Split
Score

Subtotal Score

PART-A

I.1	Plain scale, Diagonal scale, Vernier scale, Isometric	0.25 x 4		1
I.2	Third quadrant	1		1
I.3	Lines of intersection of horizontal plane and vertical plane	1		1
I.4	Circle, Ellipse, Parabola, Hyperbola	0.25 x 4		1
I.5	Absolute coordinate system, Relative coordinate system, Polar coordinate system			1

PART-B

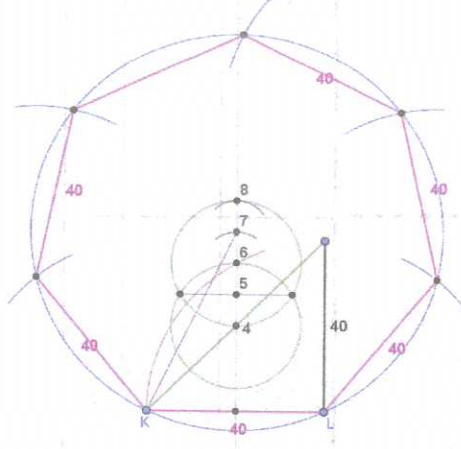
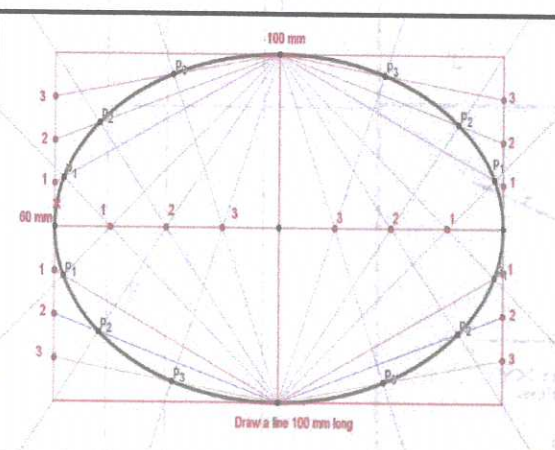
II.1		7+1 (Dimension and neatness)		8
II.2		7+1 (Dimensioning)		8

<p>II.3</p>		<p>7+1(Dimensioning and neatness)</p>	<p>8</p>
<p>II.4</p>		<p>7+1(Dimensioning)</p>	<p>8</p>
<p>II.5</p>		<p>2+2+2+2</p>	<p>8</p>
<p>II.6</p>	<p>Front view having true length</p> <p>70</p> <p>35°</p> <p>VP</p> <p>HP</p> <p>Top view lies in XY since the line lies in the VP</p> <p>End M lying in both HP & VP</p>	<p>8</p>	<p>8</p>

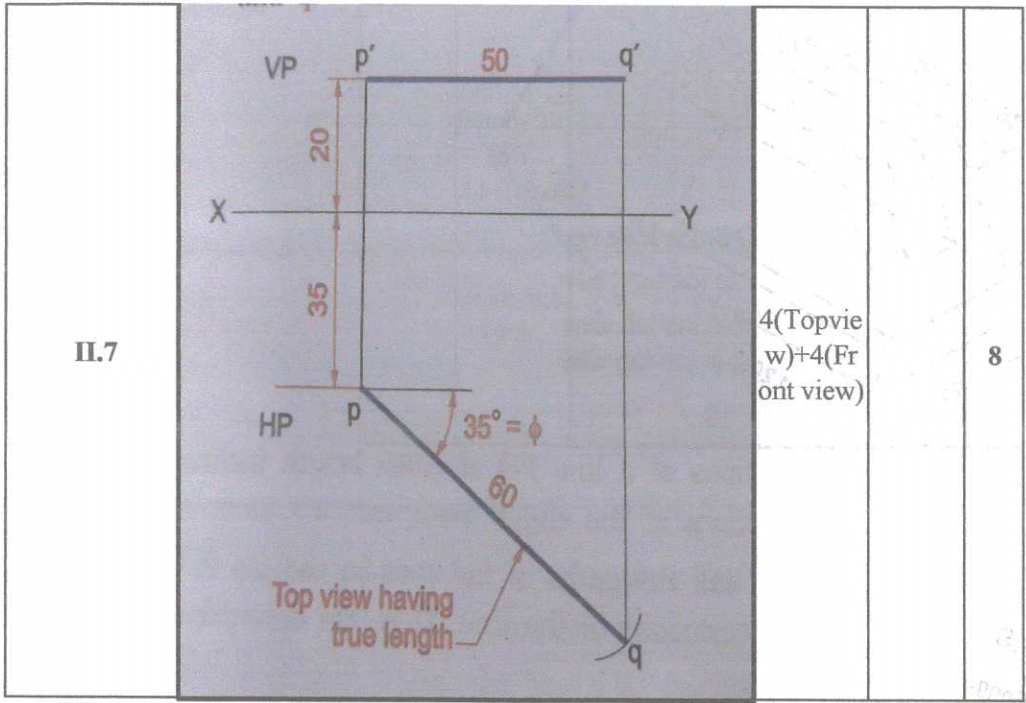

PART-C
(Maximum Marks:30)

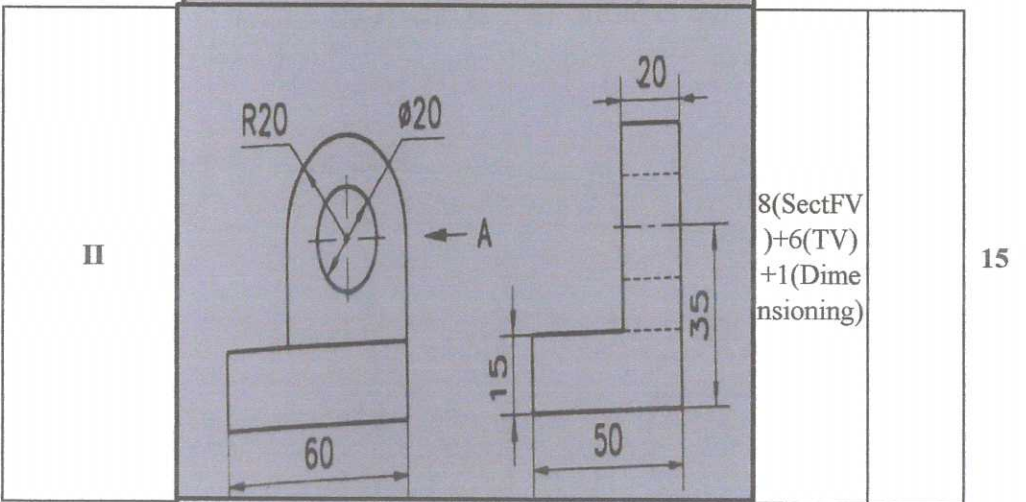
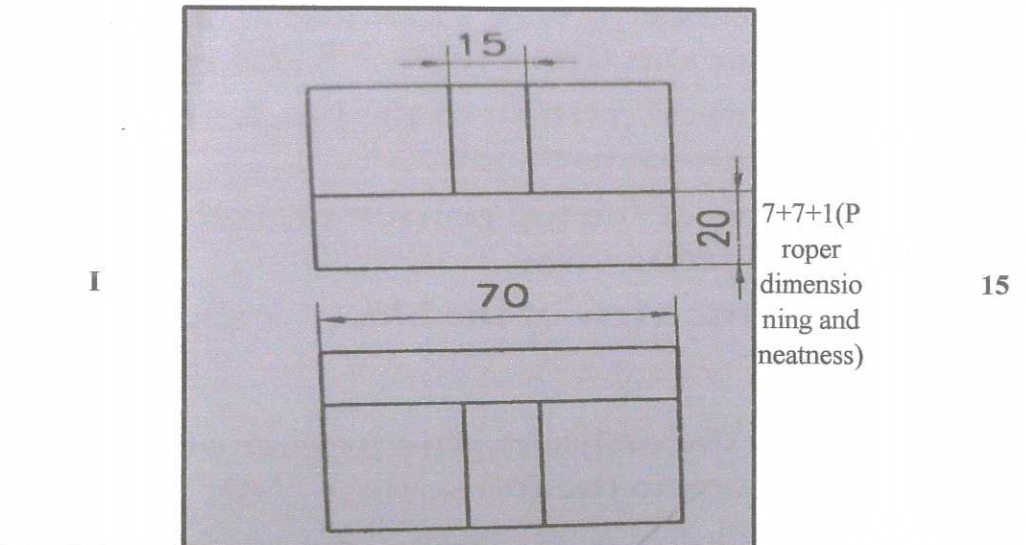

K. S. CHANDRAN, B.E.
 Lecturer in Mechanical Engg.
 Central Polytechnic College
 Thiruvananthapuram - 13

III

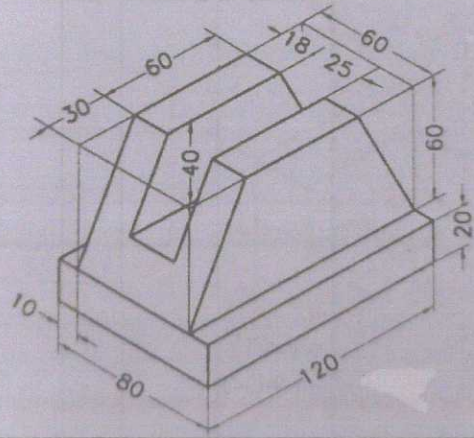

2(isometric axes)+11
+2(Proper dimensioning)

