

(34) 8/11/23

SET 2

Scoring Indicators

(12) NOV-8

COURSE NAME: ELECTRIC CIRCUITS & NETWORKS

COURSE CODE: 3041

QID: 2110220232

Q. No	Scoring Indicators	Split Score	Sub Total	Total Score
PART A				9
I. 1	It is the ratio of the r.m.s value to the average value.	1	1	1
I. 2	$X_L = X_C$ or $X_L - X_C = 0$ or net reactance = 0.	1	1	1
I. 3	According to Ohm's law. $I = V/R$	1	1	1
I. 4	Autotransformer.	1	1	1
I. 5	$E_g = \frac{P\Phi ZN}{60A}$	1	1	1
I. 6	Torque.	1	1	1
I. 7	Salient Pole Rotor and Cylindrical Rotor.	0.5*2= 1	1	1
I. 8	Stepper motor.	1	1	1
I. 9	Universal motors.	1	1	1
PART B				24
II. 01	<p>Power factor: The ratio of the actual electrical power dissipated by an AC circuit to the product of the r.m.s. values of current and voltage. The range is from 0 to 1. It is given by $PF = \cos\phi$, where ϕ is the phase lead or lag caused by the reactive loads.</p> <p>Reactive Power: reactive power is the imaginary power or apparent power, which does not do any useful work. It is a by product of AC systems and produced from inductive and capacitive loads. It exists when there is phase displacement between voltage and current. It is measured in units of volt-ampere reactive (VAR). It is given by $VI\sin\phi$.</p>	1.5*2 = 3	3	3

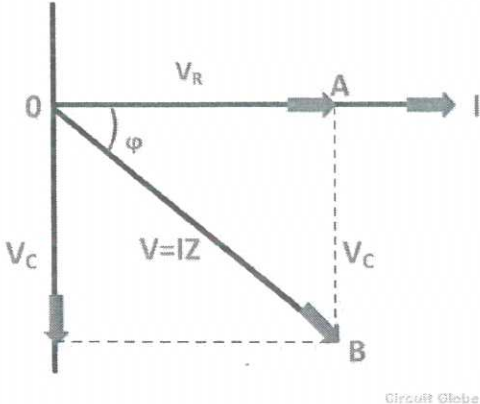
II. 02	 <p style="text-align: center; font-size: small;">Circuit Globe</p>	1.5	3	3																				
	<ul style="list-style-type: none"> • Take the current I as a reference vector. • Voltage drop in resistance $V_R = I_R$ is taken in phase with the current vector. • Voltage drop in capacitive reactance $V_C = I X_C$ is drawn 90 degrees behind the current vector, as current leads voltage by 90 degrees (in the pure capacitive circuit). • The vector sum of the two voltage drops is equal to the applied voltage V. 	1.5																						
II. 03	<table border="1" style="width: 100%; border-collapse: collapse;"> <thead> <tr> <th style="width: 10%;">Sl.no</th> <th style="width: 20%;">Item</th> <th style="width: 15%;">series</th> <th style="width: 15%;">parallel</th> </tr> </thead> <tbody> <tr> <td>1</td> <td>Z at resonance</td> <td>Minimum</td> <td>Maximum</td> </tr> <tr> <td>2</td> <td>I at resonance</td> <td>Maximum</td> <td>Minimum</td> </tr> <tr> <td>3</td> <td>p.f at resonance</td> <td>unity</td> <td>unity</td> </tr> <tr> <td>4</td> <td>Magnifies</td> <td>Voltage</td> <td>Current</td> </tr> </tbody> </table>	Sl.no	Item	series	parallel	1	Z at resonance	Minimum	Maximum	2	I at resonance	Maximum	Minimum	3	p.f at resonance	unity	unity	4	Magnifies	Voltage	Current	3*1=3(Any Three)	3	3
Sl.no	Item	series	parallel																					
1	Z at resonance	Minimum	Maximum																					
2	I at resonance	Maximum	Minimum																					
3	p.f at resonance	unity	unity																					
4	Magnifies	Voltage	Current																					
II. 04	<p>(i) A node is a point in the network or circuit where two or more circuit elements are joined.</p> <p>(ii) The most elementary form of a loop which cannot be further divided is called a mesh.</p> <p>(iii) A resistive load, being connected to a DC network, receives maximum power when the load resistance is equal to the internal resistance known as (Thevenin's equivalent resistance) of the source network as seen from the load terminals. $R_{TH} = R_L$.</p>	3*1 = 3	3	3																				
II. 05	<p>(i) Hysteresis Loss:- The core of the transformer is subjected to an alternating magnetizing force, and for each cycle of emf, a hysteresis loop is traced out. Power is dissipated in the form of heat known as hysteresis loss and given by the equation.</p> $P_h = K \eta B_{max}^{1.6} f V \text{ watts}$	1.5*2= 3	3	3																				

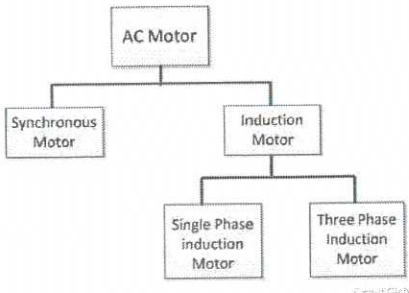
	<p>(ii)Eddy Current Loss:-The core is made of conducting material, EMFs circulate currents within the body of the material. These circulating currents are called Eddy Currents. They will occur when the conductor experiences a changing magnetic field. As these currents are not responsible for doing any useful work, and it produces a loss (I^2R loss) in the magnetic material known as an Eddy Current Loss. The equation of the eddy current loss is given as:</p> $P_e = K_e B_m^2 t^2 f^2 V \quad \text{watts}$			
<p>II. 06</p>	<p>Types & applns:- 1.Power Transformer-substations, equipment etc. 2.Auto Transformer-UPS, Stabilizers etc. 3.Instrument Transformer- (i) Current Tranformer. (ii)Voltage Transformer. -used for measurement of high voltage as in the case of distribution and transmission lines.</p>	<p>3*1=3</p>	<p>3</p>	<p>3</p>
<p>II. 07</p>	<p>When the generator is loaded, the armature carries the current. The armature current sets tip its own magnetic field. The effect of this armature flux on the distribution of main field flux is called Armature Reaction. It reduces the generated voltage by distorting the main flux and it causes sparking at the brushes. <u>Effects of Armature Reaction</u> 1.The armature reaction will reduce the generated EMF due to decrease in value of flux per pole. 2.The iron losses in the teeth and pole shoes are determined by the maximum value of flux density at which they work. Due to distortion in main field flux the maximum density at load increases above no load. 3.Thus more iron losses are observed on load than no load. 4.Due to this process the maximum value of gap flux density increases.</p>	<p>1+ 2(Any Two) =3</p>	<p>3</p>	<p>3</p>
<p>II. 08</p>	<p>The AC motor is mainly classified into two types. They are the synchronous motor and the induction motor.</p>  <pre> graph TD A[AC Motor] --> B[Synchronous Motor] A --> C[Induction Motor] C --> D[Single Phase induction Motor] C --> E[Three Phase Induction Motor] </pre>	<p>3</p>	<p>3</p>	<p>3</p>

II. 09	<p>A universal motor works on either DC or single phase AC supply. When the universal motor is fed with a DC supply, it works as a DC series motor. When current flows in the field winding, it produces a magnetic field. The same current also flows from the armature conductors. When a current carrying conductor is placed in an electromagnetic field, it experiences a mechanical force. Due to this mechanical force, or torque, the rotor starts to rotate. The direction of this force is given by Fleming's left hand rule. If the supply is DC, the polarity never reverses. So we get the field and the current in the same direction always and hence a net force in a particular direction on the conductors due to which the rotor rotates. If the supply is AC, the polarity changes between +ve and -ve, 50 times per second. So, the direction of current as well as the Magnetic Field changes and hence we get the Resultant Force in different directions.</p>	3	3	3
II. 10	<p>1. In Industries they are used in machine tools, packaging, factory automation, material handling, printing converting, assembly lines, and many other demanding applications robotics, CNC machinery, or automated manufacturing. 2. They are also used in radio-controlled airplanes to control the positioning and movement of elevators. 3. They are used in robots because of their smooth switching on and off and accurate positioning. 4. They are also used by the aerospace industry to maintain hydraulic fluid in their hydraulic systems. 5. They are used in many radio controlled toys. 6. They are used in electronic devices such as DVDs or Blue-ray Disc players to extend or replay the disc trays. 7. They are also being used in automobiles to maintain the speed of vehicles.</p>	6 * 0.5 marks = 3	3	3
PART C				42
III. 01	<p>$V_{max} = 230\sqrt{2} = 325$ $\omega = 2\pi \times 50 = 314.$ $X_c = \frac{1}{\omega C} = \frac{1}{314 \times 26.5 \times 10^{-6}} = 12\Omega.$ $I_{max} = \frac{V_{max}}{X_c} = \frac{325}{12} = 27A. \quad \phi = \frac{\pi}{2} \text{ (lead).}$ (i)v(t) = 325sin314t and i(t) = 27sin(314t+π/2)</p>	4+ 1.5+ 1.5 =7	7	7

III.02	$X_L = \omega L = 2 \times 3.14 \times 50 \times 0.2 = 63 \Omega.$ $X_C = \frac{1}{\omega C} = \frac{1}{2 \times 3.14 \times 50 \times 100 \times 10^{-6}} = 32 \Omega.$ <p>Therefore $X = X_L - X_C = 63 - 32 = 31 \Omega$ (inductive)</p> <p>(i) Impedance, $Z = \sqrt{R^2 + X^2} = \sqrt{(20)^2 + (31)^2} = 37 \Omega$</p> <p>(ii) $I = \frac{V}{Z} = \frac{220}{37} = 5.95 \text{ A}.$</p> <p>(iii) $V_R = I \times R = 5.95 \times 20 = 119 \text{ V}.$ $V_L = I \times X_L = 5.95 \times 63 = 375 \text{ V}.$ $V_C = I \times X_C = 5.95 \times 32 = 190 \text{ V}.$</p> <p>(iv) Power factor $= \cos \phi = \frac{R}{Z} = \frac{20}{37} = 0.54$</p>	2 1 3 1	7	7
III.03	<p>(i) Thevenin resistance is found by opening the circuit between the specified terminal and shorting all voltage sources. When the 10V source is shorted, we get: $R_{th} = (1 2) + 3 = 3.67 \text{ ohm}.$</p> <p>(ii) 4 ohm is removed and then v across 2 ohm is calculated by voltage divider $2 \times 10 / (2 + 1) = 6.67 \text{ V}.$ Voltage between A and B i.e. V_{th} is equal to voltage across 4 ohm resistance since no current flow through 3 ohm resistance. So, $V_{th} = 6.67 \text{ V}.$</p> <p>(iii) On drawing the Thevenin equivalent circuit, we get R_{th}, 4 ohm and V_{th} in series. Applying Ohm's law, $I = V_{th} / (4 + R_{th}) = 0.87 \text{ A}.$</p> <p>(iv) load voltage $= 0.87 \times 4 = 3.48 \text{ V}.$</p>	2 + 2 + 2 + 1 = 7	7	7
III.04	<p>(i) Here at first let's consider the 10 A current source and replace the 5 V voltage source with a short circuit as shown below.</p>	3+3+1 =7	7	7

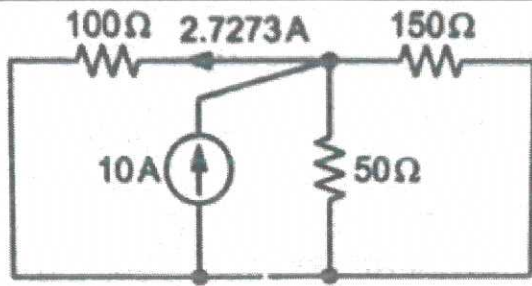

Now the current through 100 Ω resistor is calculated as

$$I_1 = 10 \times \frac{\frac{1}{100}}{\frac{1}{100} + \frac{1}{50} + \frac{1}{150}} = \frac{0.1}{0.01 + 0.02 + 0.00667} = 2.7273 \text{ Amps}$$

(ii) Now let's consider a 5 V voltage source and replace the 10 A current source with open circuits shown below.

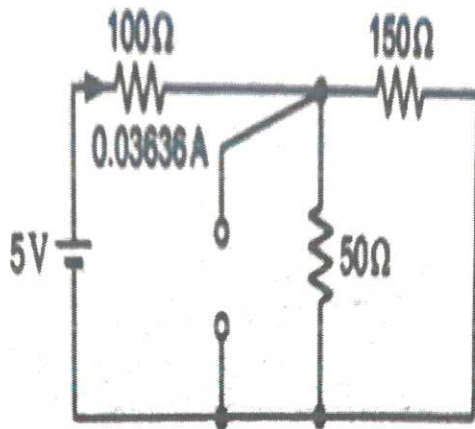

Then current through 100 Ω resistor is calculated as

$$I_2 = \frac{V}{R''}$$

Where, R'' is the equivalent resistance given by,

$$R'' = 100 + 50 || 150 = 100 + \frac{50 \times 150}{50 + 150} = 137.5 \Omega$$

$$\text{Then, } I_2 = \frac{5}{137.5} = 0.03636 \text{ Amps}$$

(iii) The total current through 100 Ω resistor with the reference direction as shown in Figure: 2 is given by

$$I_{100\Omega} = I_1 + I_2 = -2.7273 + 0.03636 = -2.691 \text{ Amps}$$

Kirchhoff's Current Law states that "the algebraic sum of all the currents at any node point or a junction of a circuit is zero". $\Sigma I = 0$

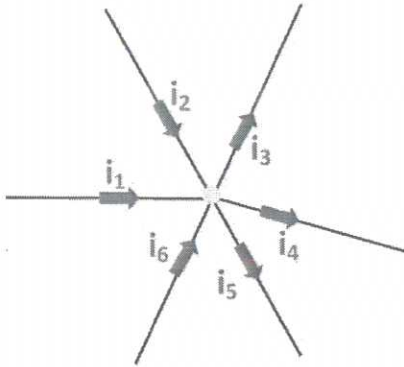

Circuit Globe

Considering the above figure as per the Kirchhoff's Current Law: $i_1 + i_2 - i_3 - i_4 - i_5 + i_6 = 0 \dots\dots\dots (1)$

III.
05

The direction of incoming currents to a node is taken as positive while the outgoing currents are taken as negative. That is $i_1 + i_2 + i_6 = i_3 + i_4 + i_5$

Sum of incoming currents = Sum of outgoing currents

Kirchhoff's Voltage Law states that in a closed circuit, the algebraic sum of all the EMFs and the algebraic sum of all the voltage drops (IR) is zero. That is $\Sigma IR + \Sigma e.m.f = 0$.

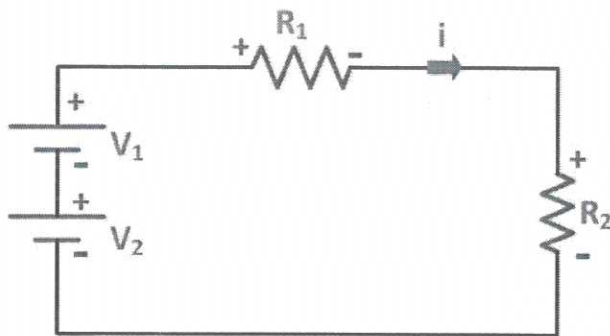

Circuit Globe

The above figure shows closed-circuit also termed as a mesh. As per the Kirchhoff's Voltage Law:

7

7

3.5*2
=
7

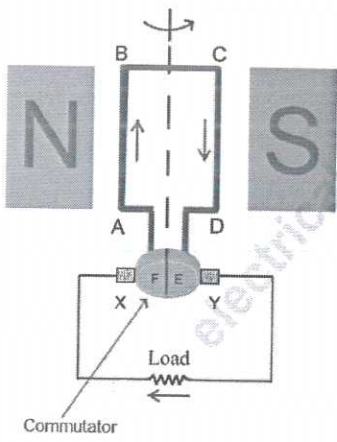
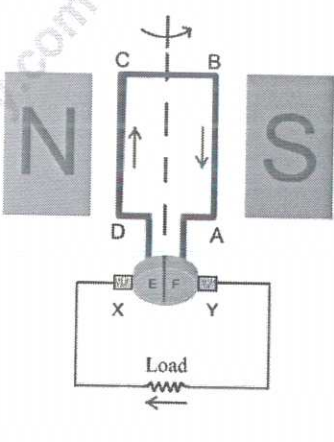
	$-V_1 + (-V_2) + iR_1 + iR_2 = 0 \dots\dots\dots (2)$ <p>Here, the assumed current I causes a positive voltage drop when flowing from the positive to negative potential while negative potential drop when the current flowing from negative to the positive potential.</p>			
III. 06	<p>Let N_1 = no of primary turns and N_2 = no of secondary turns. Φ_m = max flux in core in Wb and f = frequency in Hz. The flux increase from zero value to max value Φ_m in $\frac{1}{4}$ of cycle ie; $\frac{1}{4f}$ second. Then average rate of change of flux = $\Phi_m / (\frac{1}{4f}) = 4 \Phi_m f$ Wb.</p> <p>Rate of change of flux/turns = e.m.f induced in volts. Average e.m.f/turn = $4 \Phi_m f$ volt. r.m.s value of e.m.f/turn = form factor x average value. $= 1.11 \times 4 \Phi_m f = 4.444 \Phi_m f$</p> <p>EMF induced in the whole primary winding, $E_1 = 4 \Phi_m f N_1$ volts and EMF induced in the whole secondary winding, $E_2 = 4 \Phi_m f N_2$ volts.</p>	7	7	7
III. 07	<div style="display: flex; justify-content: space-around;"> <div style="text-align: center;">  <p>Case 1</p> </div> <div style="text-align: center;">  <p>Case 2</p> </div> </div> <p>The DC generator working principle is based on Faraday's laws of electromagnetic induction. When a conductor is located in an unstable magnetic field, an electromotive force gets induced within the conductor. The induced e.m.f magnitude can be measured from the equation of the electromotive force of a generator. If the conductor is present with a closed lane, the current which is induced will flow in the lane. In this generator, field coils will generate an electromagnetic field as well as the armature conductors are turned into the field. Therefore, an electromagnetically</p>	Dia -3 Exp-4	7	7

induced electromotive force (e.m.f) will be generated within the armature conductors. The path of induced current will be provided by Fleming's right-hand rule. According to Fleming's right hand rule, the direction of induced current changes whenever the direction of motion of the conductor changes. Let's consider an armature rotating clockwise and a conductor at the left is moving upward. When the armature completes a half rotation, the direction of motion of that particular conductor will be reversed to downward. Hence, the direction of current in every armature conductor will be alternating. If you look at the above figure, you will know how the direction of the induced current is alternating in an armature conductor. But with a split ring commutator, connections of the armature conductors also gets reversed when the current reversal occurs. And therefore, we get unidirectional current at the terminals.

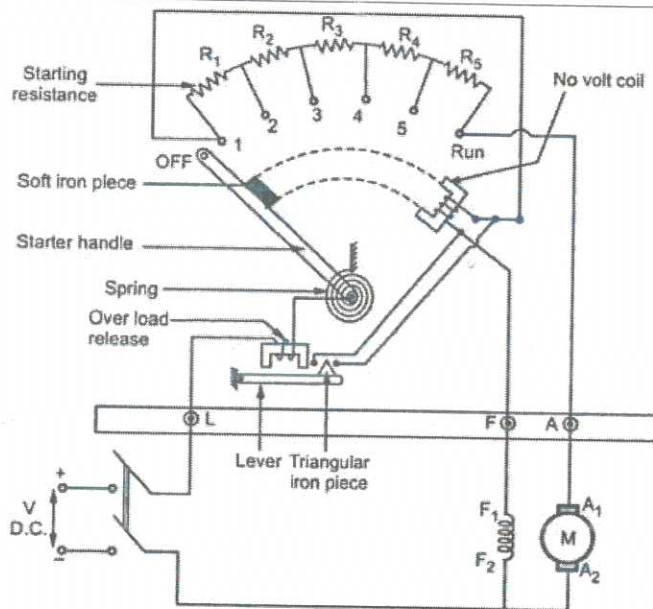

III.
08

The handle is in OFF position: When power is switched on to the motor. The handle is slowly moved to stud '1' against the spring force, the following will happen: Field winding will get supply via parallel path provided through stud 1 and PVC. Entire starting resistance is series with the armature and limits the starting current. As the motor picks up speed, the back emf develops and the armature current drops down. As the handle moves further to stud 2, it cuts the resistance between 1 and 2 and so the armature current increases. As the motor gains speed, again backemf raises which lowers the current. The handle is then moved tp

Dia-4
Exp-3

7

7

	<p>points 3,4,5 and finally RUN position, where it gets locked magnetically by the holding coil. It bypasses the starting resistance and the motor rotates at normal speed. The handle comes back to the initial starting position with the help of the helical spring.</p>			
<p>III. 09</p>	<div data-bbox="395 398 1082 757" data-label="Diagram"> </div> <p>A machine that converts DC electrical power into mechanical power is known as a Direct Current motor. DC motor working is based on the principle that when a current carrying conductor is placed in a magnetic field, the conductor experiences a mechanical force. The direction of this force is given by Fleming's left-hand rule and magnitude is given $F = BIL$ Newton. Consider a part of a multipolar DC motor as shown in the figure below. When the terminals of the motor are connected to an external source of DC supply the field magnets are excited developing alternate North and South poles. The armature conductors carry currents. All conductors under North-pole carry currents in one direction while all the conductors under South-pole carry currents in the opposite direction.</p>	<p>Dia-3 Exp-4</p>	<p>7</p>	<p>7</p>
<p>III. 10</p>	<p>Separately Excited:- A DC generator whose field winding or coil is energized by a separate or external DC source is called a separately excited DC Generator</p> <div data-bbox="300 1456 670 1758" data-label="Diagram"> </div> <p>Self Excited These are the generators whose field magnets are energized by the current supplied by themselves. In these type of machines field coils are internally connected with the armature. According to the position of the field coils the Self-excited DC generators may be classified as</p>	<p>Dia-5 Exp-2</p>	<p>7</p>	<p>7</p>

- A. Series wound generators
- B. Shunt wound generators
- C. Compound wound generators

Series Wound Generator

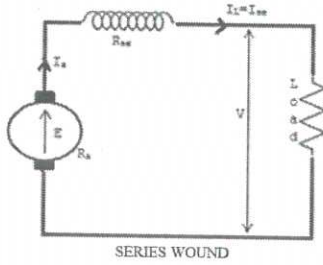

Shunt Wound DC Generators

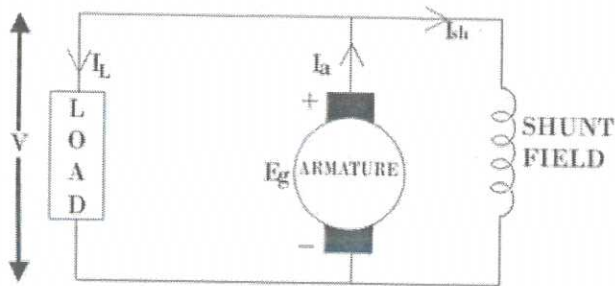

Short Shunt Compound Wound DC Generator

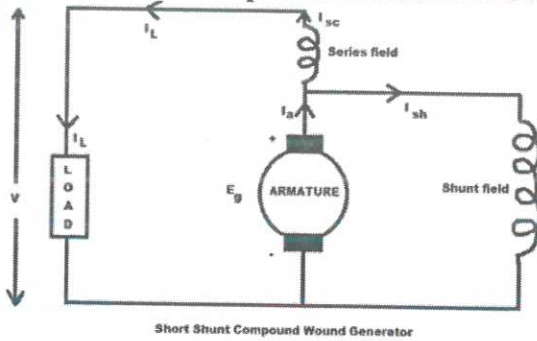

Long Shunt Compound Wound DC Generator

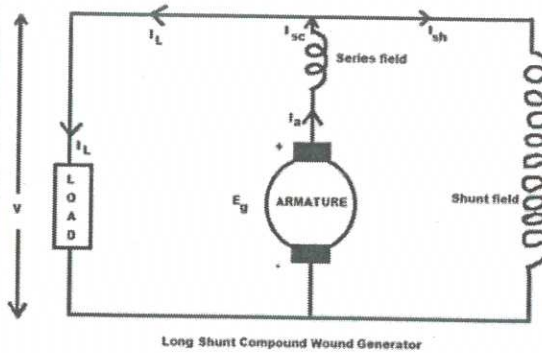

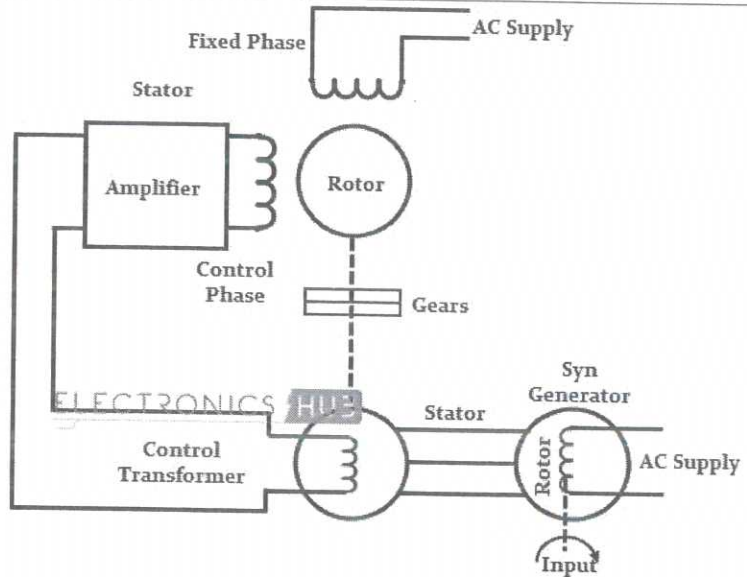

III.
11

Dia-3
Exp-4

7

7

The reference input is given to the rotor of synchro generator as mechanical input. This rotor is connected to the electrical input at rated voltage at a fixed frequency. The three stator terminals of a synchro generator are connected correspondingly to the terminals of control transformer. The angular position of the two-phase motor is transmitted to the rotor of control transformer through gear train arrangement. Initially, there exist a difference between the synchro generator shaft position and control transformer shaft position. This error is reflected as the voltage across the control transformer. This error voltage is applied to the servo amplifier and then to the control phase of the motor. With the control voltage, the rotor of the motor rotates in required direction till the error becomes zero. This is how the desired shaft position is ensured in AC servo motors.

III.
12

Sl. No	Particulars	Squirrel-cage Induction motor	Slip-ring Induction motor
1	construction	simple	Not simple
2	cost	low	high
3	efficiency	high	low
4	Starting torque	low	high
5	Maintenance cost	Very less	more
6	Speed control	difficult	easy
7	reliability	Very reliable	reliable

1*7=7

7

7