

112

112

13/11/23

14

Nov-23

SET2

QID:2109230093

Course : OPTICAL COMMUNICATION AND NETWORKING
TED(21)-5043A

Blue Print

Mark Distribution

Module	hr / Module	Marks/Module ($h_i / \sum H_i$) * 123 ($\pm 5\%$)	Type of Questions							
			Part A		Part B		Part C		Total	
			No of Questions	Marks	No of Questions	Marks	No of Questions	Marks	No of Questions	Marks
1	14	29.69	2	2	4	12	2	14	8	28
2	16	33.93	3	3	1	3	4	28	8	34
3	14	29.69	2	2	4	12	2	14	8	28
4	14	29.69	2	2	1	3	4	28	7	33
Total	58	123	9	9	10	30	12	84	31	123

COGNITIVE LEVEL WISE QUESTION ANALYSIS

Mark Distribution

CognitiveLevel	%Marks	Mark s	TYPEOFQUESTIO NS							
			PARTA		PARTB		PARTC		TOTAL	
			No of Questions	Marks	No of Questions	Marks	No of Questions	Marks	No of Questions	Marks
R	20	24.6	8	8	4	12	0	0	12	20
U	60	73.8	0	0	5	15	12	84	17	99
A	20	24.6	1	1	1	3	0	0	2	4
Total	100	123	9	9	10	30	12	84	31	123

SET2

SCHEME OF VALUATION



Scoring Indicators

COURSE NAME : OPTICAL COMMUNICATION AND NETWORKING REV 2021

COURSE CODE :5043A

QID : 2109230093

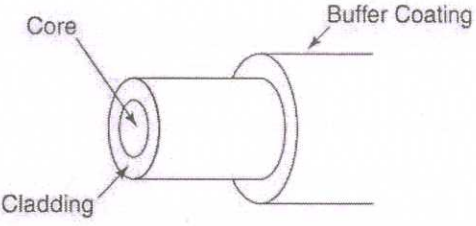
Q No	Scoring Indicators	Split score	Sub Total	Total score
PART A				9
I. 1	$\eta = C/V$, $V = C/\eta$, $C = 3 \times 10^8$ m/sec, $\eta = 1.31$ $V = \left(\frac{C}{\eta}\right) = (3 \times 10^8)/1.31 = 2.29 \times 10^8$ m/sec	1	1	
I. 2	1.The Refractive Index of core > Refractive Index of cladding ie: ($\eta_1 > \eta_2$) 2.At core-cladding interface the angle of incidence >critical angle	0.5*2=1	1	
I. 3	LED, LASER	0.5*2	1	
I. 4	Avalanche photo diode(APD)	1	1	
I. 5	Stimulated	1	1	
I. 6	To achieve population inversion	1	1	
I. 7	Modal dispersion (Inter-modal dispersion) Chromatic Dispersion (Intra-modal dispersion) Polarization mode dispersion (PMD) (any two)	0.5*2=1	1	
I. 8	Synchronous optical network	1	1	
I. 9	Y coupler, T coupler ,star coupler, directional coupler, WDM coupler, tree coupler, two port coupler, four port coupler, combiner, splitter(any two)	0.5*2=1	1	
PART B				24
II. 1	Advantages System performances- high bandwidth and capacity, Low signal attenuation loss, Immunity to electrical noise, high Signal security, good Electrical isolation, reduced size and weight, resistant to radiation and corrosion, Resistant to temperature variations, high flexibility Applications: Medical industry ,Communication, Defense, Broadcasting , Decorations and lighting, Bio medical research, computer networking, automotive industry, telephone, mechanical inspections, cable TV, CCTV (Any3)	Applications: 0.5*3=1.5 Adv: 0.5*3=1.5	3	

II. 2	$n_2/n_1 = \frac{\sin\theta_i}{\sin\theta_r} = \sin 40^\circ / \sin 27^\circ = 1.42$	3	3	
II. 3	Acceptance angle is the maximum angle of a ray (against the fiber axis) hitting the fiber core which allows the incident light to be guided by the core. Only light that enters the fiber at or less than the acceptance angle will be totally internally reflected at core-cladding interface	3	3	
II. 4	 <p style="text-align: center;">Optical fiber construction</p> <p>An optical fiber is made of three sections: The fibre consists of very thin layer of glass or silica called core having high refractive index which carries the light signals. The core is surrounded by a layer of glass or plastic having R.I. less than that of core known as cladding which keeps the light in the core. The buffer coating protects the cladding The RI of cladding (n_2) is always less than RI of core (n_1) The refractive index is the measure of bending of a light ray when passing from one medium to another.</p>	Fig:1.5 Expln:1.5	3	
II. 5	 <p>In order to extend the region of carrier extraction an intrinsic layer or a slightly doped layer is usually introduced between the p- and the n-region. Conversion efficiency of PN photo diode can be improved by including a lightly doped (nearly intrinsic) n layer between heavily doped p & n regions.</p>	Fig:1.5 Expln:1.5	3	
II. 6	WDM is a fiber-optic transmission technique that enables the use of multiple light wavelengths (or colors) to send data over the same medium. It is a technique in which signals of different wavelength are multiplexed together in order to get transmitted over an optical link. The advantages of WDM are: provides greater bandwidth, it allows secured transmission of optical signal, increases the signal carrying capacity of the system.	3	3	

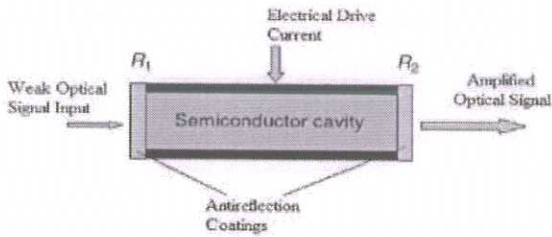
<p>II. 7</p>	<p>SOAs amplify incident light through stimulated emission. When the light traveling through the active region, it causes these electrons to lose energy in the form of photons and get back to the ground state. Those stimulated photons have the same wavelength as the optical signal, thus amplifying the optical signal.</p>  <p>The diagram illustrates a Semiconductor Optical Amplifier (SOA). It features a central rectangular 'Semiconductor cavity' flanked by mirrors labeled R_1 and R_2. Below the cavity, 'Antireflection Coatings' are indicated. An arrow labeled 'Weak Optical Signal Input' enters from the left. An arrow labeled 'Electrical Drive Current' points downwards into the top of the cavity. An arrow labeled 'Amplified Optical Signal' exits to the right.</p>	<p>Fig:1.5 Expln:1.5</p>	<p>3</p>	
<p>II. 8</p>	<p>Scattering losses in glass arise from microscopic variations in the material density, from compositional fluctuations, and from structural inhomogeneities or defects occurring during fiber manufacture. Two types of scattering losses: Linear scattering: cause the transfer of some or all of the optical power contained within one propagating mode to be transferred linearly into a different mode. This process tends to result in attenuation of the transmitted light as the transfer may be to a leaky or radiation mode which does not continue to propagate within the fiber core, but is radiated from the fiber. Three types of linear scattering are Reyleigh scattering, losses, Mie scattering losses, Waveguide scattering losses. NON- Linear scattering: The nonlinear scattering effects in optical fibers are due to the inelastic scattering of a photon to a lower energy photon. The energy difference is absorbed by the molecular vibrations or phonons in the medium. Types of non linear scattering are Stimulated Brillouin scattering, Stimulated Ramon scattering</p>	<p>3</p>	<p>3</p>	

II.9		3	3	
II.10	<p>An optical isolator is a passive device which allows the flow of optical signal power (for a particular wavelength or a wavelength band) in only one direction preventing reflections in the backward direction. Ideally, an optical isolator should transmit all the signal power in the desired forward direction. An isolator is a modified circulator with one port terminated with a matched impedance. RF isolators are two-port units that allow signals to pass in one direction while providing high isolation for reflected energy in the reverse direction.</p>	3	3	
PART C				
III	<p>According to modes optic fibers can be classified into two types. i) Single mode fiber ii) Multimode fiber.</p> <p>Single mode fiber: Single mode fiber allows propagation to light ray by only one path. Single mode fibers are best at retaining the fidelity of each light pulse over longer distance also they do not exhibit dispersion caused by multiple modes.</p> <div data-bbox="359 1411 1029 1803" style="border: 1px solid black; padding: 10px; margin: 10px 0;"> </div> <p>Multimode fiber: The term multimode simply refers to the fact that numerous modes (light rays) are carried</p>	<p>Modes: 3.5 marks (Fig: 2, explanation: 1.5)</p> <p>Profile: 3.5 marks (Fig: 2, explanation: 1.5)</p>	<p>3.5 +3. 5=7</p>	<p>42</p> <p>7</p>

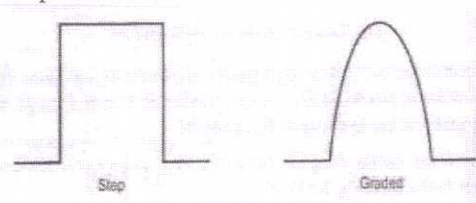
	<p>simultaneously through the waveguide. Multimode fiber has a much larger diameter, compared to single mode fiber, this allows large number of modes.</p> <p>The index profile is a graphical representation of value of refractive index across the core diameter.</p> <p>There are two basic types of index profiles. •</p> <p>1. Step index fiber</p>  <p>Fig. 1.6.12 Index profiles</p> <p>The step index (SI) fiber has a uniform refractive index of n_1 and the core is surrounded by outer cladding with uniform refractive index of n_2. The cladding refractive index (n_2) is less than the core refractive index (n_1). But there is an abrupt change in the refractive index at the core cladding interface</p> <p>2) Graded index fiber: In the graded index (GRIN) fiber the refractive index is not uniform within the core, it is highest at the center and decreases smoothly and continuously with distance towards the cladding. The refractive index profile across the core takes the parabolic nature</p>			
IV	<p>RI of core (n_1)=1.50, RI of cladding (n_2)=1.45</p> <p>$NA = \sqrt{n_1^2 - n_2^2} = \sqrt{1.50^2 - 1.45^2} = 0.38$</p> <p>Acceptance angle = $\sin^{-1} NA = \sin^{-1} 0.38 = 22.58^\circ$</p> <p>Critical angle = $\sin^{-1} (n_2/n_1) = 75.16^\circ$</p>	3+2+2	7	7
V	<p>The basic detection process is shown in fig below with a p-n photodiode. The device is reverse biased so the holes and electrons moves towards to their majority sides, creating a depletion region on either side of junction. This barrier stops further diffusion of charge carriers across the junction .</p> <p>When a photon incident in the depletion region of this device which has an energy equal or greater than band gap energy(E_g) ie: $h\nu > E_g$, an electron is excited from valence band into conduction band. This process leaves an empty hole in conduction band and is known as photo generation of electron – hole pair. Shown in fig a</p>	Fig:4 Expln:3	7	7

	<p>The carriers so generated near the junction are separated and drift under the influence of electric field to produce a current in external circuit as in fig:b Photogeneration and the separation of a carrier pair in the depletion region of this reverse-biased p-n junction is illustrated in Figure (c)</p>			
VI	<p>Absorption:</p> <p>Stimulated Absorption: happens when a photon of light having energy $E_2 - E_1 = h\nu$ (as shown in the figure) is incident on an atom in the ground state, the atom in the ground state E_1 may absorb the photon and jump to a higher energy state E_2. This process is called stimulated absorption or induced absorption. This is called so because the incident photon has stimulated the atom to absorb the energy.</p> <p><u>Spontaneous emission:</u> Spontaneous emission is an energy conversion process in which an excited electron or molecule decays to an available lower energy level and in the process gives off a photon. This process occurs naturally and does not involve interaction of other photons. Consider an atom initially at excited state E_2 as in fig. Excited state with higher energy is unstable and so the atom cannot stay for a long time ,it jumps to lower level by emitting a photon of frequency ν</p>	2+ 2.5+ 2.5	7	7

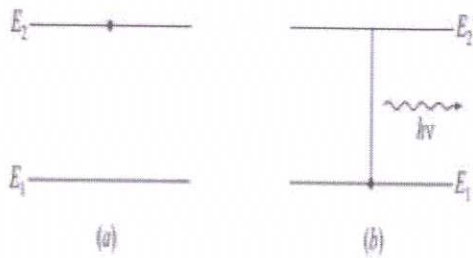

Stimulated emission:

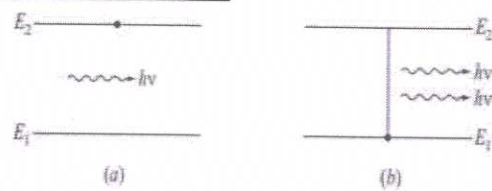

If an atom is in an excited state of energy E_2 and an incident photon of suitable energy ($h\nu = E_2 - E_1$) may cause the atom (electron) to jump to lower energy state ($\approx E_1$) emitting an additional photon of same frequency, same phase and in the same direction. Thus now two photons each of energy equal to $E_2 - E_1$ are present. This kind of transition is called stimulated emission of radiation.

VII	PIN diode :	APD :	Any 7 1*7=7m arks	7	7
	PIN photodiode does not have a high-intensity electric field region.	APD is a high-intensity electric field region.			
	An undoped intrinsic(i) layer is placed between two heavily doped regions	an intrinsic π layer is placed between p and p+ layer			
	Sensitivity is very low	Sensitivity is very high			
	The responsibility of a PIN diode is limited	The responsibility of APD can have much larger values,			
	S/N ratio is very poor.	S/N ratio is better.			
	Conversion efficiency is 0.5 to 1.0 amps/watt.	Conversion efficiency is 0.5 to 100 Amps/watt.			
	The response time of PIN is half that of APD	The response time of APD is almost double that of the PIN			
	The detector circuit is very simple.	The detector circuit is complex			
Photo current generated is less than that of APD	Photo current generated is higher				

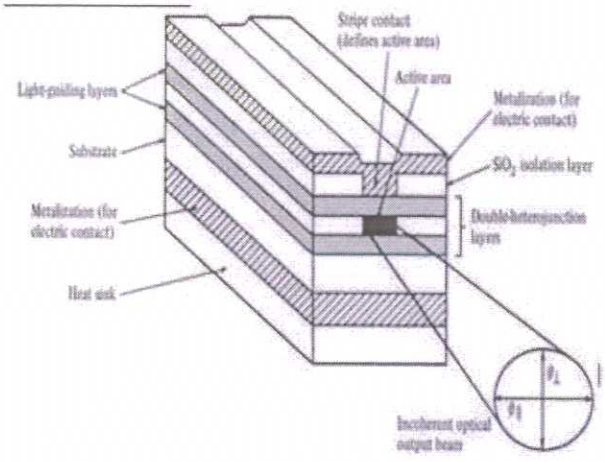
	Exhibit lower noise levels	exhibit higher noise levels as compared to PIN			
VIII	 <p>The edge emitter LED consists of an active pn junction region where the photons are generated and two light-guiding layers that function in the same manner as an optical fiber. This structure forms a waveguide channel that directs the optical radiation toward the edge of the device, where it can be coupled into an optical fiber.</p> <p>The emission pattern of the edge emitter is more directional than that of a surface emitter, which allows a greater percentage of the emitted light to be coupled into a fiber. The emitting area is smaller as a result of which the coupling to the end of a fiber is more efficient.</p> <p>In the case of edge emitter, the light is more directional. In this case the double heterostructure is surrounded by a semiconductor having a larger band gap than that of the active layer. This makes the process of recombination to be confined to the active layer.</p> <p>The surrounding layer acts as a dielectric waveguide. The light coming out of the waveguide is coupled to the optical fiber by a lens system.</p>		Fig:4 Expln:3	4+3 =7	7
IX	<p>The carrier is modulated using analog information signal. The variation of light emitting from the optical source is a continuous signal. The information source provides an electrical signal to the transmitter. The transmitter comprises electrical stage. The electrical stage (circuits) drives an optical source. The optical source output is a light which is intensity modulated by the information. The optical source converts the electrical signal into an optical signal. The source may be either semiconductor laser or Light Emitting Diode (LED). The</p>		Fig:4+ Expln:3	7	7

intensity modulated light signal is coupled to fiber. The fiber acts as a channel between the transmitter and receiver. At the receiver the optical signal is detected by the optical detectors such as PIN diode and Avalanche photodiode. Repeaters and Optical Amplifier: To compensate for signal degradation in long distance convert optical signal to electrical

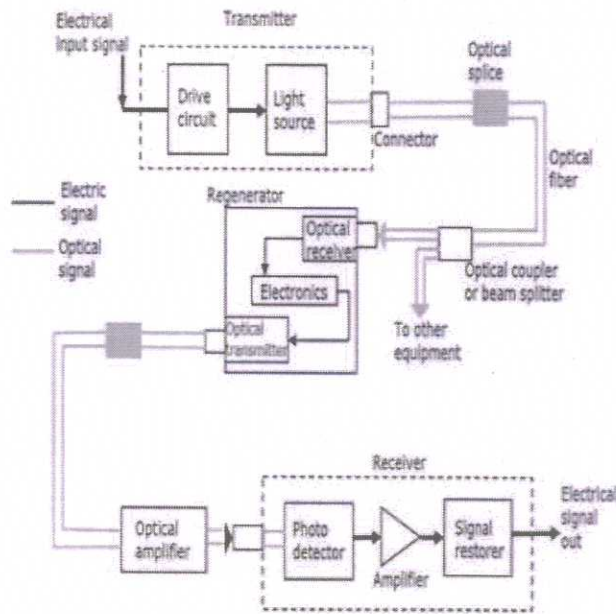

X The active medium in an optical fiber amplifier consists of a 10-30m length of optical fiber that is lightly doped with Erbium(Er+).
 The active medium in an optical fiber amplifier consists of a 10-30m length of optical fiber that is lightly doped with Erbium(Er+).
 Pump laser using wavelength 980 & 1480nm is used
 In normal operation pump laser emitting 980 nm is used to excite electrons from ground state to pump level by transition 1
 The excited electrons decay quickly to metastable level as by transition 2 which is radiated as mechanical vibrations
 The absorption of pump photon excite electron from ground state to metastable state by transition 3. These electrons tend to move towards the lower end of metastable level by transition 4.
 Some of electrons at metastable level decays to ground level by spontaneous emission by transition 5
 Spontaneous absorption by transition 6
 Stimulated emission and amplification by transition 7

Fig:4+
Expln:3

7

7

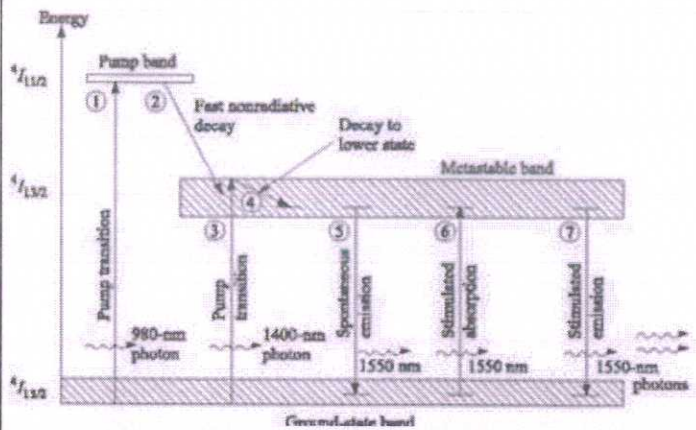

Or

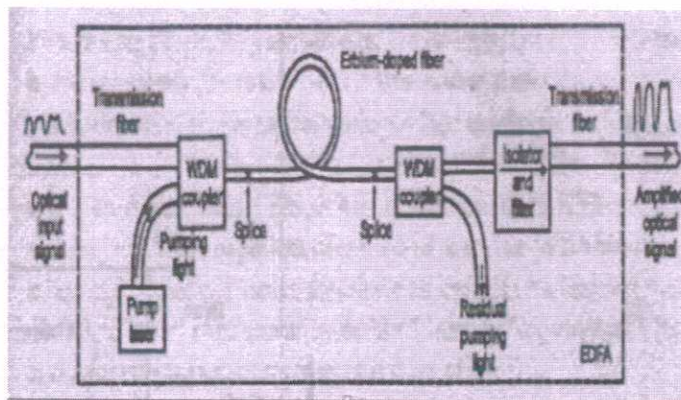

<p>XI</p>	<p>Optical splices: A fiber optic splice is a permanent fiber joint whose purpose is to establish an optical connection between two individual optical fibers. Fiber optic splices also permit repair of optical fibers damaged during installation, accident, or stress. These are typically used to create long optical links or in situations where frequent connection and disconnection are not needed</p> <p>Optical beam splitters: optical components used to split incident light at a designated ratio into two separate beams. Beam splitters can be used in reverse to combine two different beams into a single one . Beam splitters are a basic element of many optical fiber communication systems often providing a Y-junction by which signals from separate sources can be combined, or the received power divided between two or more channels.</p>	<p>2+ 2.5+ 2.5</p>	<p>7</p>	<p>7</p>
-----------	--	----------------------------	----------	----------

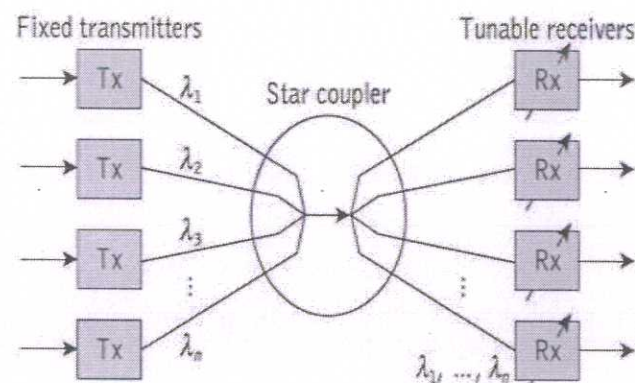
	<p>Optical modulator is a device that modulates or varies the amplitude of an optical signal in controlled manner. These devices manipulate some properties of light beams, such as the optical power or phase. It generates desired intensity, colour in the passing light by changing parameters such as transmission factor, refractive index, reflection factor, and degree of deflection in the optical system according to modulating signal</p>			
<p>XII</p>	<p>Optical circulators are nonreciprocal multiport passive device that directs light sequentially from port to port in only one direction .In optical circulators, the light is transmitted between the ports in a predefined sequence in Fig. where a 3-port configuration is presented A basic optical circulator is a three-terminal device as illustrated in Fig. where terminal 1 is the input port and terminal 2 is the output port, while the reflected signal back into terminal 2 will be redirected to terminal 3 instead of terminal 1.</p>	<p>Fig:3+ expln=4</p>	<p>7</p>	<p>7</p>
<p>XIII</p>	 <p>Broadcast-and-select optical networks consist of a number of nodes. These nodes are connected through optical fibers to a passive star coupler. In broadcast-and- select optical networks, nodes are equipped</p>	<p>Fig:3+ expln:4</p>	<p>7</p>	<p>7</p>

	<p>with fixed or tunable transmitters to transmit signals on different wavelengths. These signals are combined into a single signal by the passive star coupler. Then, this combined signal is broadcasted to all the nodes in the network.</p> <p>A tunable receiver at the destination node extracts the desired signal from the entire group of wavelength multiplexed transmitted signals (i.e. $\lambda_1, \lambda_2, \lambda_3, \dots, \lambda_n$).</p> <p>The power of the transmitted signal is split equally among all the output ports leading to all nodes in the network. Each node can select a required wavelength to receive the desired signal by tuning its receiver to that wavelength.</p>			
XIV	<div data-bbox="363 636 820 824" data-label="Diagram"> </div> <p>Directional couplers are multiple waveguide couplers used for co-directional coupling. They are used in power splitters, optical switches, wavelength filters etc. Their basic function is to sample RF signals at a predetermined degree of coupling, with high isolation between the signal ports and the sampled ports. Since they are passive devices, they also operate in the reverse direction, with signals injected into the main path according to the devices' directionality and degree of coupling. Directional couplers are devices that will pass signal across one path while passing a much smaller signal along another path. The circuit symbol for a directional coupler is shown in Fig. No. There are three outputs and one input. The IN-OUT path is low-loss and is the principal path between the signal source and the load. The coupled output is a sample of the forward path while the isolated port shows very low signal. If the IN and OUT are reversed, then the roles of the coupled and isolated ports also reverse.</p>	Fig:3+ expln:4	7	7