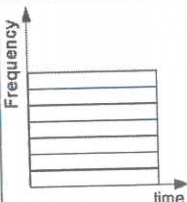
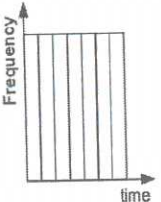
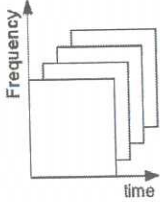

Q No	Scoring Indicators	Split score	Sub Total	Total score
<b>PART A</b>				<b>9</b>
I. 1	Cell		1	
I. 2	Frequency Division Multiple Access (FDMA)		1	
I. 3	Visitor Location Register(VLR)		1	
I. 4	General Packet Radio Service		1	
I. 5	3 <sup>rd</sup> Generation Partnership Projects (3GPP)		1	
I. 6	IEEE 802.16		1	
I. 7	2.4 GHz ISM Band		1	
I. 8	Release 8		1	
I. 9	eNodeB		1	
<b>PART B</b>				<b>24</b>
II. 1	Telecom regulatory body in India is called TRAI- Telecom regulatory authority of India. Established in 1997. Works under Union Govt. Aims to provide fair and transparent environment in Industry. Board consists of one chairperson and maximum two full time and two part-time members.	(Any general information about TRAI can be given Mark)	3	
II. 2	Analogue Technology, Low Capacity, Limited coverage, Large cell size, Analogue Roaming.	Any three of this can be given one mark each.	3	
II. 3	Home Location Register(HLR), Visitor Location Register(VLR), EIR(Equipment Identity Register)	One mark Each	3	
II. 4	1. Televoting, 2. Call screening, 3. Local number portability, 4. Toll-free calls/Free phone, 5. Prepaid calling, 6. Account card calling, 7. Virtual private networks (such as family group calling), 8. Centrex service (Virtual PBX), 9. Private-number plans (with numbers remaining	Any three of this can be awarded mark. One mark each	3	

	<p>unpublished in directories), Universal Personal Telecommunications service (a universal personal</p> <ol style="list-style-type: none"> <li>10. telephone number),</li> <li>11. Mass-calling service,</li> <li>12. Prefix free dialing from cellphones abroad,</li> <li>13. Seamless MMS message access from abroad,</li> <li>14. Reverse charging,</li> <li>15. Home Area Discount,</li> <li>16. Premium Rate calls</li> <li>17. Call distribution based on various criteria associated with the call</li> <li>18. Location-based routing, Time-based routing,</li> <li>19. Proportional call distribution (such as between two or more call centres or offices)</li> <li>20. Call queueing,</li> <li>21. Call transfer</li> </ol>			
II. 5	<ul style="list-style-type: none"> <li>• EDGE-Enhanced Data Rate for GSM Evolution</li> <li>• Considered as 2.75G</li> <li>• It provides an evolutionary migration path from GPRS to UMTS.</li> <li>• It is standardized by 3GPP.</li> <li>• EDGE is used for any packet switched application, like an Internet connection.</li> <li>• It uses 8PSK modulation in order to achieve a higher data transmission rate. The modulation format is changed to 8PSK from GMSK (GMSK is used in GSM)</li> <li>• EDGE delivers higher bit-rates per radio channel and it increase the capacity and performance.</li> </ul>	Any 3 points. One mark for each point.	3	
II. 6	<ul style="list-style-type: none"> <li>• UTRAN-UMTS Terrestrial Radio Access Network</li> <li>• Connects mobile user to Core network of UMTS.</li> <li>• Consists of NodeB and RNC.</li> <li>• NodeB ( Same function of BTS in GSM)</li> <li>• RNC- Radio Network Controller- which controls a number of Node Bs.</li> </ul>	Any 3 points can be awarded mark. One mark for each	3	
II. 7	<ul style="list-style-type: none"> <li>• OVVSF stands for orthogonal variable spreading factor codes.</li> <li>• The OVVSF codes are used as the channelization codes in</li> </ul>	Any 3 points can be awarded mark. One mark for	3	

	<p>WCDMA system.</p> <ul style="list-style-type: none"> <li>• These codes are orthogonal to each other.</li> <li>• Used to spread data signal in the system.</li> <li>• At Transmitter data multiplied with OVSF Code its bandwidth increases, that is spreading happens.</li> <li>• At receiver the spread signal multiplied by same OVSF code, therefore we will get the de-spread code</li> </ul>	each.																																									
II. 8	<table border="1"> <thead> <tr> <th>Specifications</th> <th>LTE</th> <th>LTE Advanced</th> </tr> </thead> <tbody> <tr> <td>Standard</td> <td>3GPP Release 8</td> <td>3GPP Release 10</td> </tr> <tr> <td>Bandwidth</td> <td>supports 1.4MHz, 3.0MHz, 5MHz, 10MHz, 15MHz, 20MHz</td> <td>70MHz Downlink(DL), 40MHz Uplink(UL)</td> </tr> <tr> <td>Data rate</td> <td>300 Mbps Downlink(DL) 4x4MIMO and 20MHz, 75 Mbps Uplink(UL)</td> <td>1Gbps Downlink(DL), 500 Mbps Uplink(UL)</td> </tr> <tr> <td>Theoretical Throughput</td> <td>About 100Mbps for single chain(20MHz,100RB,64QAM), 400Mbps for 4x4 MIMO. 25% os this is used for control/signaling(OVERHEAD)</td> <td>2 times than LTE</td> </tr> <tr> <td>Maximum No. of Layers</td> <td>2(category-3) and 4(category-4,5) in the downlink, 1 in the uplink</td> <td>8 in the downlink, 4 in the uplink</td> </tr> <tr> <td>Maximum No. of codewords</td> <td>2 in the downlink, 1 in the uplink</td> <td>2 in the downlink, 2 in the uplink</td> </tr> <tr> <td>Spectral Efficiency(peak,b/s/Hz)</td> <td>16.3 for 4x4 MIMO in the downlink, 4.32 for 64QAM SISO case in the Uplink</td> <td>30 for 8x8 MIMO in the downlink, 15 for 4x4 MIMO in the Uplink</td> </tr> <tr> <td>PUSCH and PUCCH transmission</td> <td>Simultaneously not allowed</td> <td>Simultaneously allowed</td> </tr> <tr> <td>Modulation schemes supported</td> <td>QPSK, 16QAM, 64QAM</td> <td>QPSK, 16QAM, 64QAM</td> </tr> <tr> <td>Access technique</td> <td>OFDMA (DL),DFTS-OFDM (UL)</td> <td>Hybrid OFDMA(DL), SC-FDMA(UL)</td> </tr> <tr> <td>carrier aggregation</td> <td>Not supported</td> <td>Supported</td> </tr> <tr> <td>Applications</td> <td>Mobile broadband and VOIP</td> <td>Mobile broadband and VOIP</td> </tr> </tbody> </table>	Specifications	LTE	LTE Advanced	Standard	3GPP Release 8	3GPP Release 10	Bandwidth	supports 1.4MHz, 3.0MHz, 5MHz, 10MHz, 15MHz, 20MHz	70MHz Downlink(DL), 40MHz Uplink(UL)	Data rate	300 Mbps Downlink(DL) 4x4MIMO and 20MHz, 75 Mbps Uplink(UL)	1Gbps Downlink(DL), 500 Mbps Uplink(UL)	Theoretical Throughput	About 100Mbps for single chain(20MHz,100RB,64QAM), 400Mbps for 4x4 MIMO. 25% os this is used for control/signaling(OVERHEAD)	2 times than LTE	Maximum No. of Layers	2(category-3) and 4(category-4,5) in the downlink, 1 in the uplink	8 in the downlink, 4 in the uplink	Maximum No. of codewords	2 in the downlink, 1 in the uplink	2 in the downlink, 2 in the uplink	Spectral Efficiency(peak,b/s/Hz)	16.3 for 4x4 MIMO in the downlink, 4.32 for 64QAM SISO case in the Uplink	30 for 8x8 MIMO in the downlink, 15 for 4x4 MIMO in the Uplink	PUSCH and PUCCH transmission	Simultaneously not allowed	Simultaneously allowed	Modulation schemes supported	QPSK, 16QAM, 64QAM	QPSK, 16QAM, 64QAM	Access technique	OFDMA (DL),DFTS-OFDM (UL)	Hybrid OFDMA(DL), SC-FDMA(UL)	carrier aggregation	Not supported	Supported	Applications	Mobile broadband and VOIP	Mobile broadband and VOIP	Any 3 points can be awarded mark. One mark for each.	3	
Specifications	LTE	LTE Advanced																																									
Standard	3GPP Release 8	3GPP Release 10																																									
Bandwidth	supports 1.4MHz, 3.0MHz, 5MHz, 10MHz, 15MHz, 20MHz	70MHz Downlink(DL), 40MHz Uplink(UL)																																									
Data rate	300 Mbps Downlink(DL) 4x4MIMO and 20MHz, 75 Mbps Uplink(UL)	1Gbps Downlink(DL), 500 Mbps Uplink(UL)																																									
Theoretical Throughput	About 100Mbps for single chain(20MHz,100RB,64QAM), 400Mbps for 4x4 MIMO. 25% os this is used for control/signaling(OVERHEAD)	2 times than LTE																																									
Maximum No. of Layers	2(category-3) and 4(category-4,5) in the downlink, 1 in the uplink	8 in the downlink, 4 in the uplink																																									
Maximum No. of codewords	2 in the downlink, 1 in the uplink	2 in the downlink, 2 in the uplink																																									
Spectral Efficiency(peak,b/s/Hz)	16.3 for 4x4 MIMO in the downlink, 4.32 for 64QAM SISO case in the Uplink	30 for 8x8 MIMO in the downlink, 15 for 4x4 MIMO in the Uplink																																									
PUSCH and PUCCH transmission	Simultaneously not allowed	Simultaneously allowed																																									
Modulation schemes supported	QPSK, 16QAM, 64QAM	QPSK, 16QAM, 64QAM																																									
Access technique	OFDMA (DL),DFTS-OFDM (UL)	Hybrid OFDMA(DL), SC-FDMA(UL)																																									
carrier aggregation	Not supported	Supported																																									
Applications	Mobile broadband and VOIP	Mobile broadband and VOIP																																									
II.9	Connectivity, interoperable communication protocol, identity of things, scalability, Dynamic or Self-Adapting Architecture, Safety, Intelligence, Embedded Sensors and Actuators, Data transfer, End point management, Active engagement, etc	Any 3 points can be awarded mark. One mark for each.	3																																								
II.10	<ul style="list-style-type: none"> <li>• Voice over LTE (VoLTE) is a technology that enables voice calls to be made over the Long-Term Evolution (LTE) network, which is the standard for high-speed wireless communication commonly referred to as 4G.</li> <li>• VoLTE represents a significant advancement in telecommunications and has several advantages over traditional circuit-switched voice calls</li> <li>• VoLTE is based on the IP Multimedia Subsystem (IMS) architectural framework.</li> </ul>	Explaining What is VoLTE-2mark Any two features-1 mark	3																																								

	<ul style="list-style-type: none"> <li>• Superior voice quality, faster call setup,</li> <li>• Can use voice and data service simultaneously</li> </ul>			
	<b>PART C</b>			<b>42</b>
III.	<p>Multiple access techniques used to access channel in a communication system.</p> <p><b>FDMA</b>-allots a different sub-band of frequency to each different user to access the network. In FDMA a channel is not in use, the channel is left idle instead of allotting to the other users. Continuous transmission possible.</p> <p><b>TDMA</b>-Used when continuous transmission not required. Time slot given for each user. Full bandwidth can be allotted to a user. Handoff process simple.</p> <p><b>CDMA- Code Division Multiple Access (CDMA)</b>-Code division multiple access technique is an example of multiple access where several transmitters use a single channel. Full spectrum can be used by a single user. Continuous transmission possible. Provides soft handoff.</p> <div style="display: flex; justify-content: space-around; align-items: flex-end;"> <div style="text-align: center;">  <p>FDMA</p> </div> <div style="text-align: center;">  <p>TDMA</p> </div> <div style="text-align: center;">  <p>CDMA</p> </div> </div> <p><b>Space Division Multiple Access (SDMA)</b>- Space division multiple access or spatial division multiple access is a technique which is MIMO (multiple-input multiple-output) architecture and used mostly in wireless and satellite communication</p> <p><b>Spread Spectrum Multiple Access(SSMA)</b>- Spread spectrum multiple access (SSMA) uses signals which have a transmission bandwidth whose magnitude is greater than the minimum required RF bandwidth. Two type Spread spectrum techniques- <b>FHSS, DSSS</b></p>	<p>Figure- 3 marks. Explaining any 3 multiple access techniques and naming other can be give 4 marks. Explaining all the techniques without figure can be given 7 marks</p>	7	

**Cellular network organization** refers to the hierarchical structure and arrangement of cellular networks for efficient and reliable communication. It typically consists of three main components: cell, base station, and Mobile Switching Center (MSC). The network is divided into small geographical areas called cells, each served by a base station. These cells are designed to minimize interference and maximize coverage. Shape of a cell in a network is assumed to be **Hexagon**.

IV. **FREQUENCY REUSE**-- The design process of selecting and allocating channel groups for all of the cellular base stations within a system is called frequency reuse or frequency planning. Adjacent channels allocated different frequency groups.

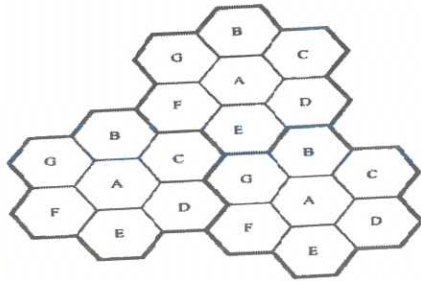

Figure shows diagram of seven cell cluster system. 7 cells allocated seven different group of frequencies from A to G. Nearby cells given different frequency groups.

3 marks cellular network organization and 4 marks for frequency re-use

7

**Reflection**-Reflection occurs when a propagating electromagnetic wave impinges upon an obstacle that has very large dimensions compared to the wavelength of the propagating wave. During propagation, the electromagnetic wave usually encounters obstacles such as: walls, buildings, Earth's surface, water surface, etc. Depending on the reflecting surface (obstacle surface), the reflected signal suffers additional attenuation.

V.



**Diffraction**- Diffraction happens when radio waves encounters obstacle of sharp edges. In diffraction, the electromagnetic wave "breaks" on the sharp edge of the obstacle and continues to propagate further weakened.

Explanation- 4 marks

Figures 3 marks

Explanation without figures also can give full mark if sufficient information given

7

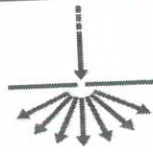

**Scattering-** Scattering occurs when the medium through which the wave propagates consists of objects with dimensions that are small compared to the wavelength, and where the number of obstacles per unit volume is large.

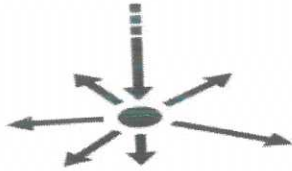

**Multipath propagation-** The multi path propagation effect is a propagation phenomenon which implies that electromagnetic waves reach the receiving antenna by multiple paths

Multi path propagation effect

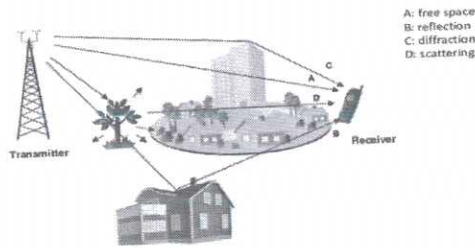

Capacity improvement Techniques are **splitting, sectoring, and coverage zone** .

VI. **Cell Splitting-** Cell splitting is the process of subdividing a congested cell into smaller cells, each with its own base station and a corresponding reduction in antenna height and transmitter power. Cell splitting increases the capacity of a cellular system since it increases the number of times that channels are reused

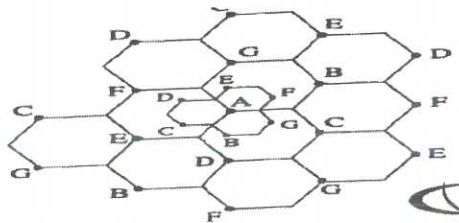

**Cell sectoring**

Replacing a single omni-directional antenna at the base station by

Explanation  
4 marks  
Figures 3  
marks

7

several directional antennas, each radiating within a specified sector. The factor by which the co-channel interference is reduced depends on the amount of sectoring used. A cell is normally partitioned into three 120 degree sectors or six 60° sectors

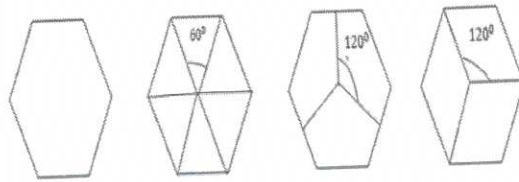
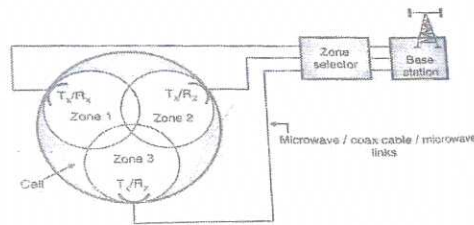

Fig. omni-directional 60° sectoring 120° sectoring

### Micro cell or coverage zone

A microcell is a cell in a mobile phone network served by a low power cellular base station (tower), covering a limited area such as a mall, a hotel, or a transportation hub. A microcell is usually larger than a picocell, though the distinction is not always clear.



VII.

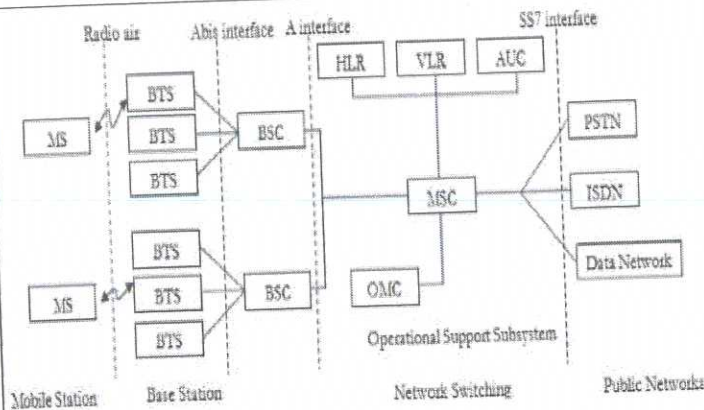

Fig: GSM Architecture

Figure shows the block diagram of architecture of GSM.

MS- Mobile station. Consists of mobile handset and SIM card.

BTS- Base Transceiver Station. MS connected to BTS through air interface called Um interface. A number of BTS connected to BSC(Base Station Controller) via Abis interface.

MSC-Mobile switching Center is the heart of a GSM network.

Registers like HLR,VLR,EIR and Authentication Center connected

Block diagram 4 marks  
Explanation 3 marks

7

to MSC.

MSC or GMSC can connect a GSM network to other networks such as PDN or PSTN.

VIII

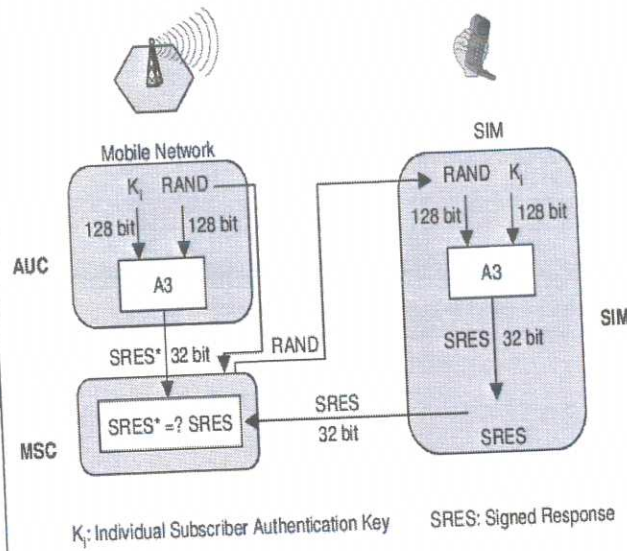

Authentication process in GSM is to authenticate a user in the network.

Each user has got a 128 Bit secret Key  $K_i$ . RAND is 128 Bit Random number is send to Mobile station. Using A3 algorithm a 32 Bit Signed Response (SRES) generated.

Authentication Center also having the same  $K_i$  and RAND. There also SRES generated. In MSC both SRES compared. If both of them are equal Authentication is successful.

Figure 4 mark  
Explanation  
3 mark.  
Whole  
process can  
be explained  
without  
figure also.

7

IX.

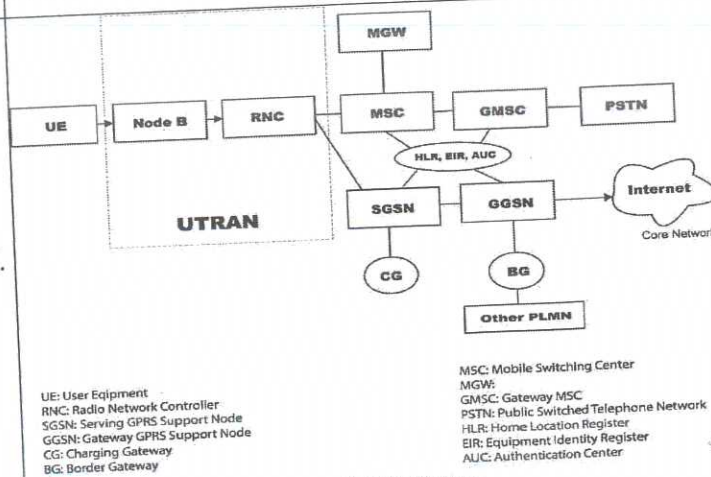

UE- user equipment( SIM+Handset) connected to NodeB. BTS in GSM replaced by NodeB in UMTS.

RNC-Radio Network Controller- Control several NodeBs and

Block  
Diagram-4  
Explanation-  
3

7

allocate radio resources. RNC-Radio Network Controller.  
 The RNC is a functional element of the UMTS RNS (Radio Network System) which controls a number of Node Bs.  
 Responsibilities of the RNC include  
**radio resource management and control,**  
**air interface security,**  
**mobility procedures and system synchronization**  
 UTRAN-(UMTS terrestrial Random Access Network) Is a collective name for NodeB and RNC. UMTS is backward compatible therefore all network elements of GSM and GPRS are there, like MSC, SGSN, GGSN etc. Gateway MSC connects UMTS networks to other Networks.

Bluetooth is universal for short-range wireless voice and data communication. It is a Wireless Personal Area Network (WPAN) technology and is used for exchanging data over smaller distances. It operates in the unlicensed, industrial, scientific, and medical (ISM) band from 2.4 GHz to 2.485 GHz. Maximum devices that can be connected at the same time are 7. Bluetooth ranges up to 10 meters. The spreading technique that it uses is FHSS (Frequency-hopping spread spectrum). A Bluetooth network is called a **piconet** and a collection of interconnected piconets is called **scatternet**.

X.

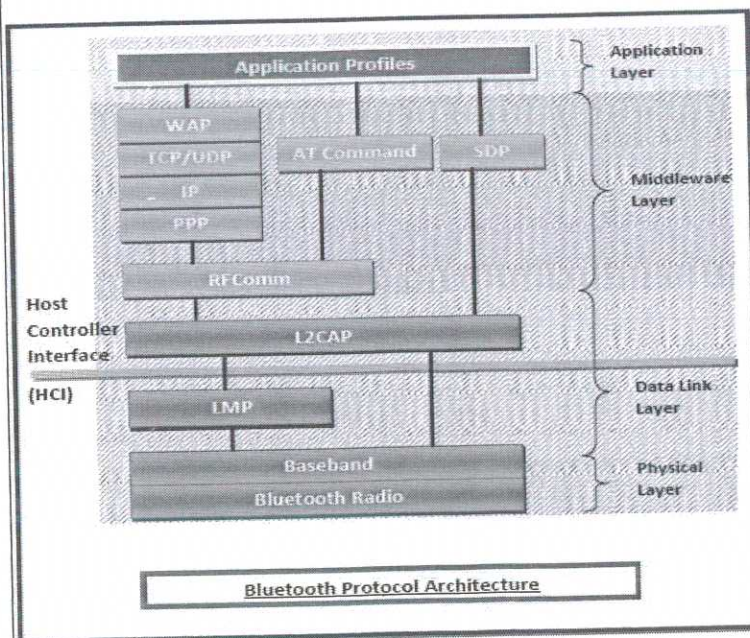

Explanation  
 3 marks  
 Figure 4  
 marks

7

The Bluetooth protocol stack is a layered architecture comprising

	<p>Bluetooth Core Protocols (HCI, L2CAP, LMP) for low-level communication, Bluetooth Profiles (e.g., A2DP, HFP) that define specific use cases (audio streaming, hands-free calling), and Application Layers for user-level interactions. These layers work together to enable wireless connections between devices, facilitating data exchange, audio streaming, and control commands, making Bluetooth a versatile wireless communication technology for various applications.</p>			
<p>XI.</p>	<p>UMTS uses <b>wideband code-division multiple access (W-CDMA) radio access technology</b> to offer greater spectral efficiency and bandwidth to mobile network operators.</p> <p>WCDMA uses spread spectrum technology, which allows multiple users to share bandwidth with no interference.</p> <p>It employs a <b>5 MHz</b> channel bandwidth (Normal CDMA only 1.25MHz)</p> <p>Using this bandwidth it has the capacity to carry over 100 simultaneous voice calls, or it is able to carry data at speeds up to 2 Mbps in its original format.</p> <p>WCDMA provides following data speeds</p> <ul style="list-style-type: none"> <li>- Stationary- 2 Mbps</li> <li>- Slow moving- 384 Kbps</li> <li>- Fast moving- 128 Kbps.</li> </ul> <p>WCDMA is considered to be more efficient than its second-generation predecessors, as well as more secure.</p> <p>Because it provides built-in encryption and relies on spread spectrum technology, WCDMA signals are much more difficult to detect. As a result, WCDMA provides more privacy for users</p> <p>To spread the signal OVSF (Orthogonal variable spreading factor codes) Codes are used.</p> <p>Data signal multiplied with a code at the transmitter. So the signal get spread. Using same code multiplied at the receiver. So original data retrieved.</p>	<p>Explaining basic concepts-4 marks</p> <p>Figure-3 marks</p>	<p>7</p>	

## Spreading/Despreading

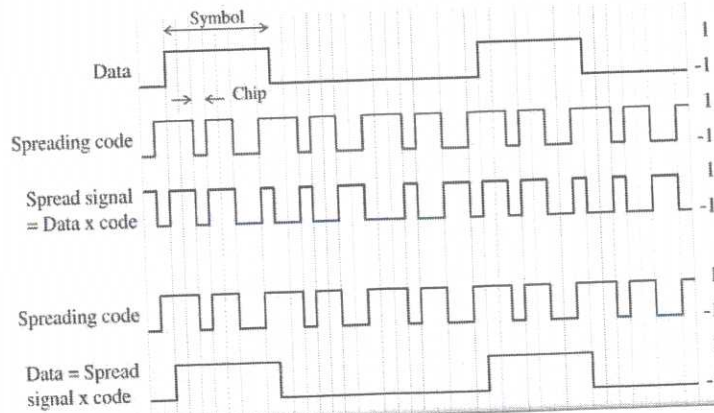

WiMAX is a technology based on the IEEE 802.16 specifications to enable the delivery of last-mile wireless broadband access as an alternative to cable and DSL. Acronym for **Worldwide Interoperability for Microwave Access**. Based on Wireless MAN technology. A wireless technology optimized for the delivery of IP centric services over a wide area. A scalable wireless platform for constructing alternative and complementary broadband networks. A certification that denotes interoperability of equipment built to the IEEE 802.16 or compatible standard.

XII. Wi-max is operated at 2.5Ghz frequency band. There will be Wi-Max antenna in the tower, and there will be customer premise equipment(CPE). CPE receives signal from the tower and then goes to a LAN network.

**Features of wimax are**

**High-Speed Data:** WiMAX offers broadband speeds, comparable to wired connections, supporting data-intensive applications like video streaming and online gaming.

**Long-Range Coverage:** It covers larger areas, reducing the need for numerous base stations, making it cost-effective for network providers.

**Scalability:** WiMAX can scale easily to accommodate more users or expand network coverage.

**Quality of Service (QoS):** It supports QoS for prioritizing different types of traffic, ensuring reliable performance for voice, video, and data.

Overall  
Explanation-  
3  
Features-4

7

**Non-Line-of-Sight (NLOS) Capability:** It can work through obstacles like buildings, enhancing its reach and usability.

**Last-Mile Connectivity:** WiMAX bridges the digital divide by providing internet access to remote and underserved areas.

LTE (Long-Term Evolution) is a 4G wireless communication standard known for its high-speed data transmission and low latency. Its architecture can be represented by a simplified block diagram, which typically consists of the following key components

## 4G | LTE ARCHITECTURE

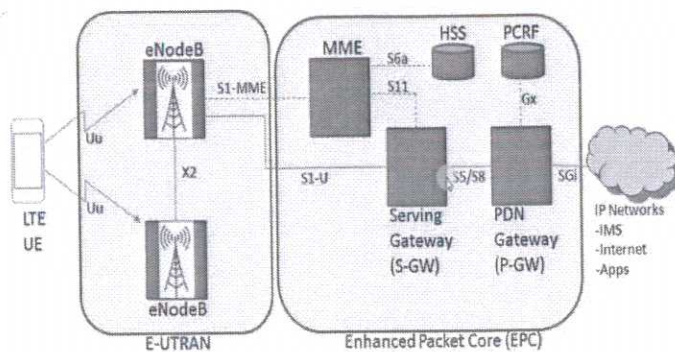

XIII

### User Equipment (UE):

- Represents the end-user device, such as a smartphone, tablet, or modem.
- Contains the LTE modem and the antenna for wireless communication.

### eNodeB (Evolved NodeB):

- Also known as the base station or cell tower.
- Responsible for radio communication with the UE.
- Handles tasks like radio resource management and handover procedures.
- Connected to the EPC (Evolved Packet Core) via an interface called S1 (for user plane) and X2 (for control plane) for communication with other eNodeBs.

### Evolved Packet Core (EPC):

- The core network of LTE, responsible for handling data and signaling traffic.
- Comprises several functional elements:
  - **MME (Mobility Management Entity):**

Block diagram 4 marks

Explanation 3 marks

7

	<p>Handles UE tracking and signaling for mobility.</p> <ul style="list-style-type: none"> <li>○ <b>SGW (Serving Gateway):</b> Routes data packets between the UE and the PDN (Packet Data Network).</li> <li>○ <b>PGW (Packet Data Network Gateway):</b> Connects the EPC to external networks, like the internet or private networks.</li> <li>○ <b>HSS (Home Subscriber Server):</b> Stores user subscription and authentication data.</li> <li>○ <b>PCRF (Policy and Charging Rules Function):</b> Enforces QoS policies and handles charging for data usage.</li> <li>○ <b>DNS (Domain Name System):</b> Resolves domain names to IP addresses.</li> </ul> <ul style="list-style-type: none"> <li>● <b>Public Data Network (PDN):</b> <ul style="list-style-type: none"> <li>• Represents the external networks, such as the internet or enterprise networks, that the UE accesses.</li> <li>• Data traffic between the UE and PDN is routed through the EPC.</li> </ul> </li> <li>● <b>Backhaul Network:</b> <ul style="list-style-type: none"> <li>• Connects eNodeBs to the core network and may include optical fibers, microwave links, or other high-capacity links.</li> </ul> </li> </ul>			
XIV	<p>5G NR (New Radio) is a new radio access technology (RAT) developed by the 3rd Generation Partnership Project (3GPP) for the 5G (fifth generation) mobile network. It was designed to be the global standard for the air interface of 5G networks. It is based on orthogonal frequency-division multiplexing (OFDM), as is the 4G (fourth generation) long-term evolution (LTE) standard.</p> <p>5G NR employs a raft of new engineering techniques that move more data through the core network faster and revolutionize the discrete operations of the air interface, which is the client device's interaction with the network provider radio hardware. Some of the improvements that 5G NR introduces are the following</p> <p>diversity of spectrum that ranges from several hundred kilohertz to millimeter wave to enable various use cases, cell sizes and data rates;</p> <p>modulation -- new orthogonal frequency-division multiplexing</p>	<p>Explanation- 3 marks Any 4 features- 4 marks</p>	7	

methods -- and channel-coding techniques;  
frequency reuse algorithms, even in dense environments;  
massive multiple input, multiple output and evolved beamforming  
capabilities; and slot time operations developed to deliver ultralow-  
latency communications.

1. **Higher Data Rates:** Data rates upto 20Gbps
2. **Low Latency:** ultra-low latency,critical for applications like real-time gaming, autonomous vehicles, and remote surgery.
3. **Massive Device Connectivity:** It supports a massive number of connected devices (IoT), offering efficient use of network resources for diverse applications.
4. **Enhanced Mobile Broadband (eMBB)**
5. **Ultra-Reliable Low Latency Communications (URLLC):** It offers highly reliable connections for mission-critical applications such as industrial automation and public safety.
6. **Network Slicing:** 5G enables the creation of virtual network slices
7. **Beamforming and MIMO:** 5G utilizes advanced antenna technologies like beamforming and massive MIMO to enhance coverage, capacity, and overall network performance.
8. **Millimeter Wave (mmWave):** Utilizes higher-frequency spectrum, such as mmWave bands, to achieve ultra-fast speeds, but with shorter propagation distances requiring more base stations.
9. **Dynamic Spectrum Sharing (DSS):** Allows for more efficient spectrum utilization by sharing spectrum resources with existing 4G LTE networks during the transition to 5G.
10. **Network Function Virtualization (NFV) and Software-Defined Networking (SDN):** 5G networks leverage virtualization and software-defined approaches to enhance network flexibility and scalability.
11. **Security Enhancements:** 5G incorporates improved security measures, including stronger encryption and authentication protocols, to protect data and user privacy.
12. **Global Standardization:** 5G NR is developed following global standards, ensuring compatibility and interoperability across different networks and devices.