

101

Page: 12
April: 2024

SCHEME OF VALUATION

Scoring Indicators

Revision : 2021

QID : 2109230087

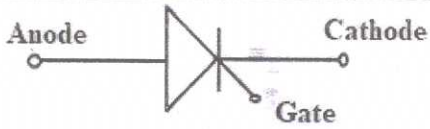

Course Title : INDUSTRIAL AUTOMATION

Course Code : 5042

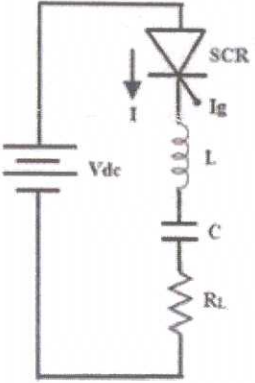
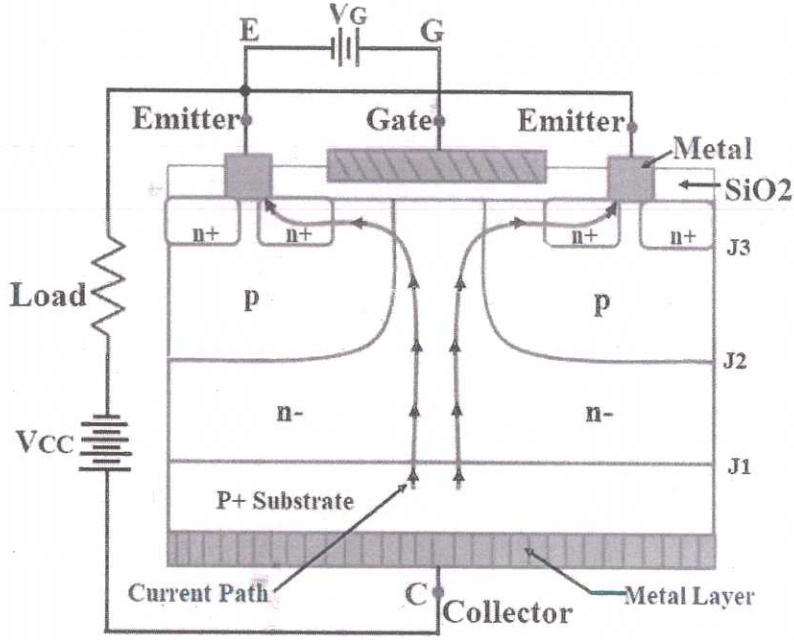
Question No.	Scoring Indicator	Split Score	Sub Total	Total
	<u>PART A</u>			9
I 1	IGBT	1	1	
I 2		1	1	
I 3	Chopper	1	1	
I 4	<ul style="list-style-type: none">• UPS• SMPS• Solar power system• Electric motor speed controller	2*0.5 (any 2)	1	
I 5	Cycloconverter	1	1	
I 6	<ol style="list-style-type: none">1. Induction heating2. Dielectric heating3. Resistance heating / Resistance welding	2*0.5 (any 2)	1	
I 7	Uninterruptable Power Supply	1	1	
I 8	Timer ON Delay, Timer OFF Delay, Retentive Timer	2*0.5 (any 2)	1	
I 9	Ladder diagram	1	1	

<u>PART B</u>				30
II 1	<ul style="list-style-type: none"> • Speed control of dc motor and induction motor • Heat control • Triggering device for SCR • Light dimmer • AC Power control 	4*0.75 (any 4)	3	
II 2		2	3	
	<p>When a DC voltage is applied, the forward current starts flowing through the SCR and the capacitor is charged up to the value of V_{dc}. Then inductor opposes the flow of current and the current begins to decrease. When the current becomes zero, the SCR turns OFF.</p>	1		
II 3		3	3	

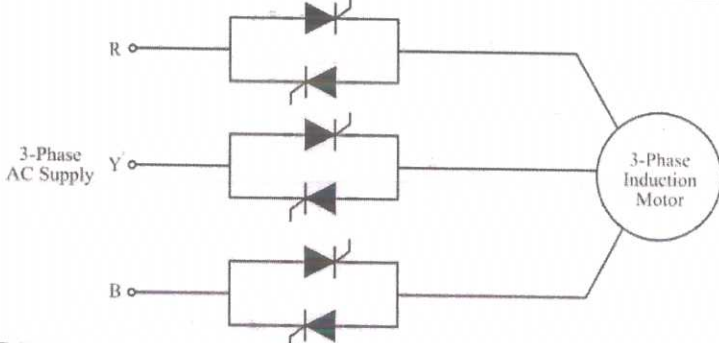
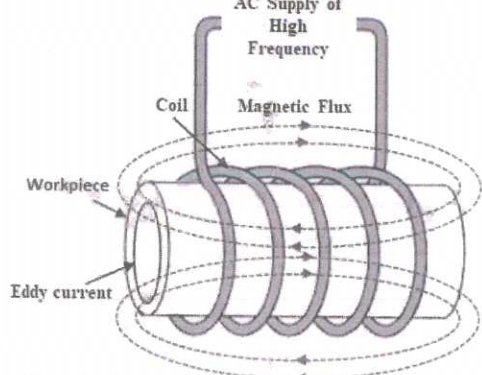
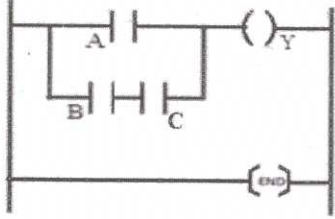
<p>II 4</p>		<p>3</p>	<p>3</p>
<p>II 5</p>	<p>The circuit consists of an inductor, diode, a switch and load.</p>	<p>2</p>	<p>3</p>
<p>II 6</p>	<ul style="list-style-type: none"> •Cement mill drives •Rolling mills •Ship propulsion drivers •Water pumps •Washing machines •Mine winders •Industries 	<p>6*0.5 (any 6)</p>	<p>3</p>

II 7		2	3
	<p>The speed of the induction motor is directly proportional to the square of the supply voltage. Hence, when the supply voltage is decreased, the speed of the motor is reduced. Each pair of the SCR controls the voltage of the phase to which it is connected. Speed control is obtained by varying the conduction period of the SCR.</p>	1	
II 8		2	3
	<p>When a high-frequency alternating current is given to the coil, an alternating magnetic field is developed. This flux induces an emf in the workpiece resulting in the flow of eddy current through it. According to the Joule heating effect, heat is produced in a conductor when current flow through it. Thus eddy current induced in the workpiece develops heat in it.</p>	1	
II 9		3	3
II 10	<p>Input instructions are</p> <ul style="list-style-type: none"> • Normally open switch • Normally closed switch 	1	3
	<p>Normally open switch</p> 	1	

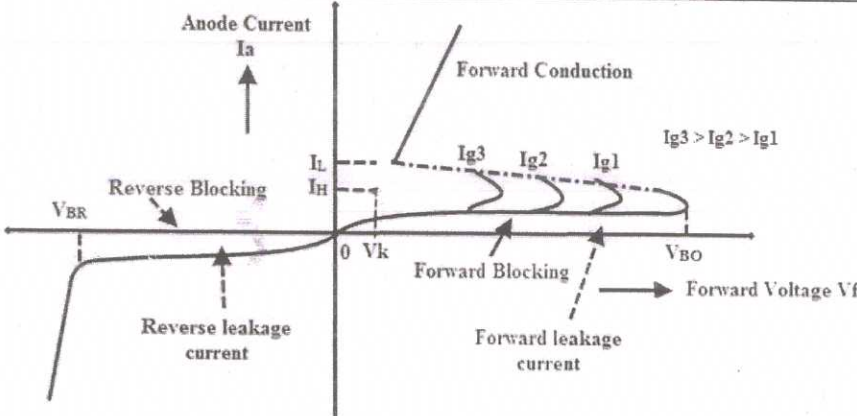
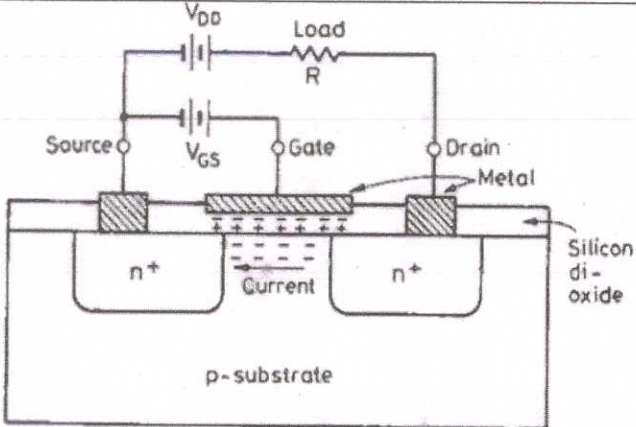
	Normally closed switch 	1		
	PART C			42
III		4	7	
	<p>When the anode is made positive with respect to cathode, SCR is forward biased and only a small leakage current flows and SCR is OFF. The forward applied voltage is then increased. At a particular forward voltage, avalanche breakdown occurs. Then SCR conducts heavily and is in ON state. Then the voltage across the SCR suddenly drops.</p> <p>When the cathode is made positive with respect to anode, SCR is reverse biased. Then only a small leakage current flows and SCR is OFF. The reverse applied voltage is then increased. At a particular reverse voltage called Reverse Breakdown Voltage, avalanche breakdown occurs. This increases the reverse current flowing through the SCR.</p>	3		
IV		4	7	

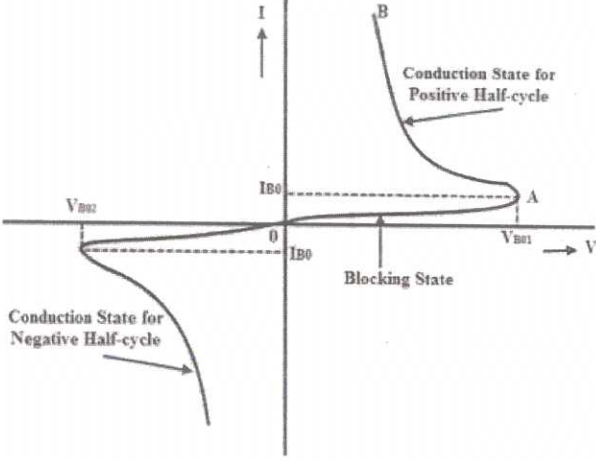
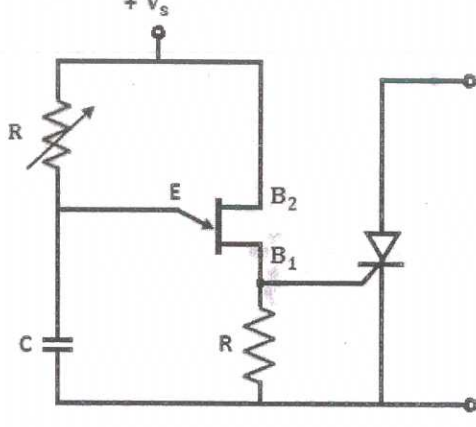
	<p>On a lightly doped P substrate, two heavily doped N-type materials are diffused to form Source and Drain. An insulating layer of silicon dioxide is placed over the substrate. Metallic contacts are made in contact with Source and Drain. In between Source and Drain terminals, a metallic plate is placed over the silicon dioxide layer and Gate terminal is taken out.</p>	3	
V		4	7
	<p>When a positive or negative voltage is applied across the diac, only a small leakage current flows. Then diac is in either forward or reverse blocking mode. As the applied voltage is increased, the leakage current continues to flow until the voltage reaches the breakover voltage. At this point, avalanche breakdown of the reverse-biased junction occurs and the device exhibits negative resistance i.e. current through the device increases with the decreasing values of applied voltage. The voltage across the device then drops. Then the current flow increases quickly and the diac comes into the conduction mode.</p>	3	
VI		3	7

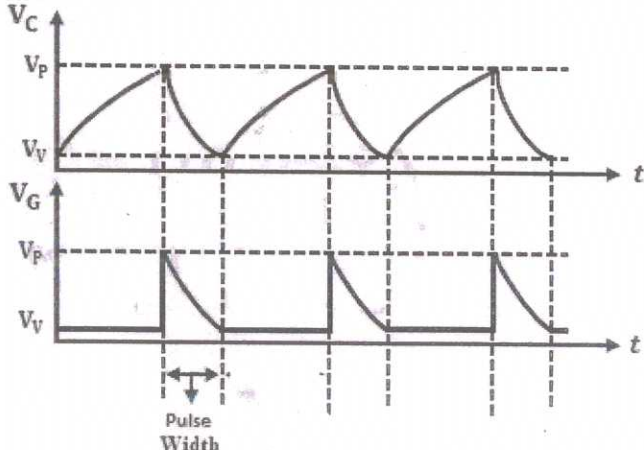
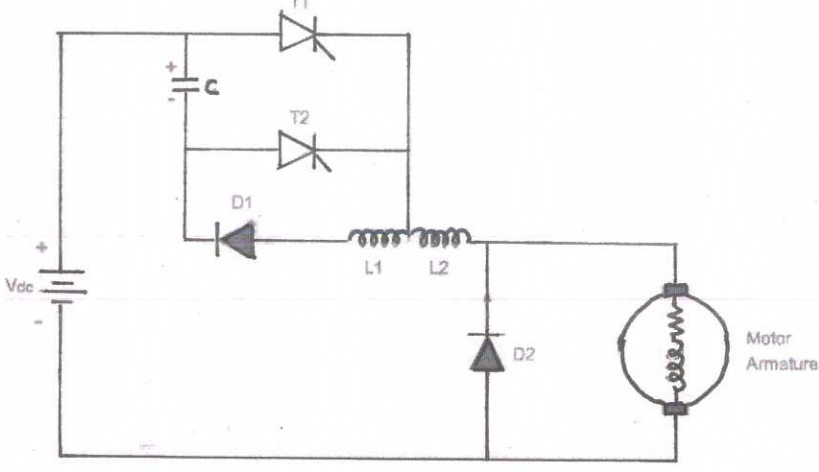
	<p>When the voltage is applied, the capacitor charges through the variable resistance R. The UJT starts conducting once the capacitor voltage is equal to the peak voltage value of the UJT. Then the capacitor starts discharging, and once its voltage decreases to the valley voltage of UJT, the UJT is turned OFF. The process repeats. Thus whenever UJT conducts, it produces pulses which are applied to the gate terminal of the SCR. The capacitor charging time depends upon the value of variable resistance. Therefore, by varying the value of variable resistance, the firing angle can be varied.</p>	2	
		2	
VII		4	7
	<p>The capacitor initially charges with upper plate positive and lower plate negative. When SCR T1 is turned on, the load current flows. The capacitor discharges. When capacitor is fully discharged, its polarity is reversed with upper plate negative and lower plate positive. Then SCR T1 gets reverse voltage and turned off. Then SCR T2 is turned on. The load current. Then the capacitor again charges with upper plate positive and lower plate negative and SCR T2 is turned off.</p>	3	

VIII

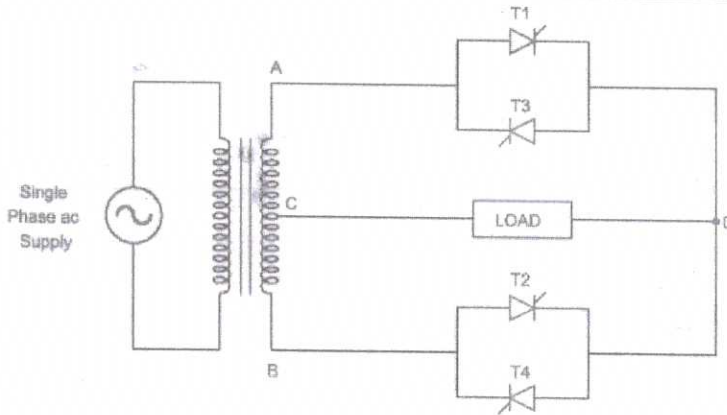

3 7

During positive half cycle, SCR T1 is turned on. The output voltage becomes positive. During negative half cycle, SCR T2 is turned on. The output voltage becomes positive. During positive half cycle, SCR T1 is turned on. Therefore the load current flows The output voltage becomes positive. Thus positive half cycle of the load voltage is obtained.

2

During negative half cycle, SCR T3 is turned on. Then the output voltage becomes negative. During positive half cycle, SCR T4 is turned on. Then the output voltage becomes negative. During negative half cycle, SCR T3 is turned on. Then the output voltage becomes negative. Thus negative half cycle of the load voltage is obtained.

Thus the output frequency is lesser than the supply frequency.

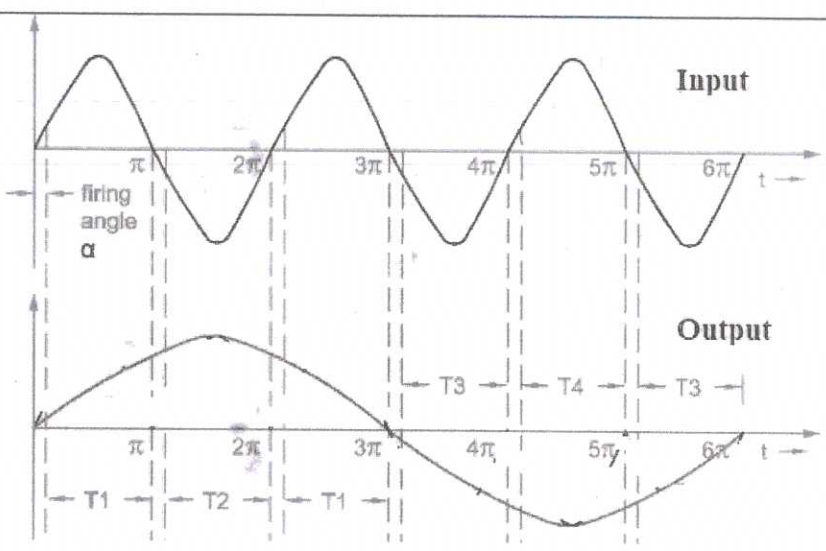

2

IX		3	7	
	<p>During the positive half cycle, SCRs T1 and T2 are forward biased and if they are triggered simultaneously at a firing-angle α, then current flows through the path L-T1-R-T2-N.</p> <p>During the negative half cycle of the ac input, SCRs T3 and T4 are forward biased and if they are triggered simultaneously at $\pi+\alpha$, current flows through the path N-T3-R-T4-L.</p>	2		
		2		
X		3	7	

	<p>Mode 1: Initially both T1 and T2 are off. Then T1 is turned on and T2 is turned off. As T1 is turned ON, the current starts flowing. The capacitor starts charging.</p> <p>Mode 2: Before switching from mode1 to mode2, a time delay is provided so that T1 can be switched off completely. After T1 is completely switched OFF, T2 is turned ON. The capacitor discharges and the current starts flowing in the opposite direction. This change of direction of current in the load shows that DC current has been converted into AC.</p>	2		
		2		
XI		4	7	

	The primary source is the filtered AC mains. When the power breakage occurs, the transfer switch will select the backup source. The stand by system will start working only when there is any failure in mains. In this system, the AC voltage is first rectified and stored in the storage battery connected to the rectifier. When power breakage occurs, this DC voltage is converted to AC voltage by means of a power inverter, and is transferred to the load connected to it.	3	
XII	Resistance welding are of 5 types. 1. Spot Welding 2. Projection Welding 3. Seam Welding 4. Butt Welding 5. Flash Butt Welding	1 (any 3)	7
	<u>1. SPOT WELDING</u> It is used for joining two or more sheets of metal. The sheets to be welded are held overlapping between the two electrodes. Heavy current is passed through the electrodes. Pressure is applied from the top electrode by moving it downward. The fusion of material takes place at the spot. The sheet is then moved to have another spot weld at the desired place. <u>2. PROJECTION WELDING</u> One of the pieces to be welded has projections produced by pressure. The electrodes are placed on work piece and current is passed between them. Heat is produced at the contacts and work piece gets welded at these points. <u>3. SEAM WELDING</u> Wheel or roller type electrodes are used. The two sheets on which welding is required are placed overlapping each other. The current is passed between the two moving electrodes. <u>4. BUTT WELDING</u> The two parts to be welded together are placed touching each other end to end. A pressure is also applied in the axial direction of weld. Heavy current is passed through them. The heat produced raises the temperature of material to plastic state and fusion takes place at the points of contact when pressure is applied on both sides. <u>5. FLASH BUTT WELDING</u> The parts to be welded are joined together under light pressure and a heavy current is passed through the joint. Due to poor contact at the joint, arcing takes place. When sufficient heat has been produced, the two parts are suddenly pressed together. A thin film is produced around the joint which is removed to give a weld of this type.	2+2+2 (any 3)	

<p>XIII</p>		<p>4</p>	<p>7</p>	
	<p>CPU is the brain of the PLC used for implementing the logic and controlling the communications among the modules that convert input signals into output signals.</p> <p>Memory unit has system program memory and user program memory. It can store programs containing control actions and data. ROM stores the data permanently for the operating system. RAM stores the information of the input and output devices.</p> <p>Power supply unit provide continuing current for the CPU and circuits and other modules.</p> <p>Input/output section provides isolation and signal conditioning functions so that sensors and actuators can be directly connected to them without the need for other circuitry.</p> <p>Outputs have relay, transistor and triac types. I/O interface's function is to convey the information and data between logic program controller and external devices.</p>	<p>3</p>		
<p>XIV</p>		<p>7</p>	<p>7</p>	