

Scoring Indicators

COURSE NAME : Medical Electronics

COURSE CODE :6041 A

QID:2102240070

| Q No. | Scoring Indicators | Split score | Sub total | Total score |
|-------|--|-------------|-----------|-------------|
| | PART A | | | 9 |
| I. 1 | Limb electrodes, Suction electrodes, Floating electrodes, Pregelled disposal electrode, Pasteless electrode. | Any two | 1 | |
| I. 2 | 0.5Hz to 50Hz | | 1 | |
| I. 3 | Hematology | | 1 | |
| I. 4 | Blood Pressure is the pressure exerted by Blood on the walls of the arteries. Normal range 120/80mmHg | | 1 | |
| I. 5 | 80-100mmHg | | 1 | |
| I. 6 | External, Internal | | 1 | |
| I. 7 | Haemodialysis | | 1 | |
| I. 8 | Macro shock ,Micro shock | | 1 | |
| I. 9 | Computed Tomography | | 1 | |
| | PART B | | | 24 |
| II. 1 | Bioelectric potentials are ionic voltages produced as a result of electro chemical activity of certain cells such as nerve cells and muscle cells. Eg:ECG,EEG,EMG | | 3 | |

9

Scoring Indicators

COURSE NAME : Medical Electronics

COURSE CODE :6041 A

QID:2102240070

| Q No. | Scoring Indicators | Split score | Sub total | Total score |
|-------|--|-------------|-----------|-------------|
| | PART A | | | 9 |
| I. 1 | Limb electrodes, Suction electrodes, Floating electrodes, Pregelled disposal electrode, Pasteless electrode. | Any two | 1 | |
| I. 2 | 0.5Hz to 50Hz | | 1 | |
| I. 3 | Hematology | | 1 | |
| I. 4 | Blood Pressure is the pressure exerted by Blood on the walls of the arteries. Normal range 120/80mmHg | | 1 | |
| I. 5 | 80-100mmHg | | 1 | |
| I. 6 | External, Internal | | 1 | |
| I. 7 | Haemodialysis | | 1 | |
| I. 8 | Macro shock ,Micro shock | | 1 | |
| I. 9 | Computed Tomography | | 1 | |
| | PART B | | | 24 |
| II. 1 | Bioelectric potentials are ionic voltages produced as a result of electro chemical activity of certain cells such as nerve cells and muscle cells. Eg:ECG,EEG,EMG | | 3 | |

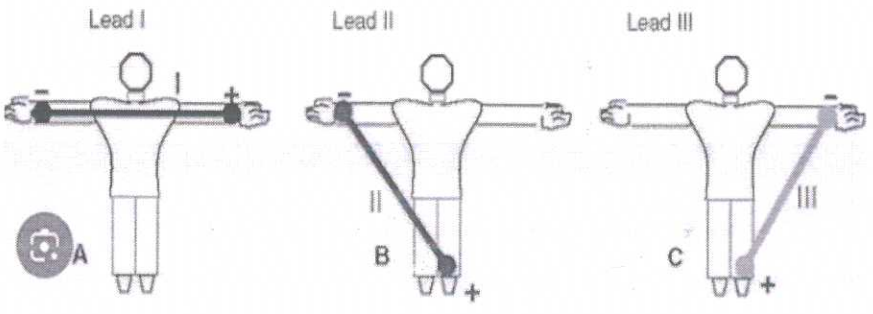
| | | | | |
|--------------|---|---|----------|--|
| <p>II. 2</p> | <p>The Standard Limb Leads are used to display a graph of the <i>potential difference</i> recorded between two limbs at a time, they are bipolar. In these leads, one limb carries a positive electrode and the other limb, a negative one.</p>  | <p>Expl :2 mark s</p> | <p>3</p> | |
| <p>II. 3</p> | <p>EMG measuring electrodes <input type="checkbox"/> surface electrode used for global pickup of muscle potential <input type="checkbox"/> Needle electrode they are inserted in the tissues via needle</p> | | <p>3</p> | |
| <p>II. 4</p> | <p>Monochromatic Coherence Directionality Highly Intense or Brightness (3 marks for four properties)</p> | <p>Any three :3</p> | <p>3</p> | |
| <p>II. 5</p> | <p>COULTER COUNTER METHOD (ELECTRICAL CONDUCTIVITY METHOD) The Coulter Principle</p> <p>When cells suspended in a low concentration solution pass through a small opening separated by two electrodes, they cause a change in the resistance in the electric circuit. The change in resistance is proportional to the particle volume displaced in the small opening . Resistance change plotted against time gives us voltage peaks. The number of peaks is equal to the number of particles and the height of the peak indicates the size of the particle.</p> <p>A platinum electrodes is placed inside the orifice tube and a second electrode is submerged into the beaker containing the cell dillution, creating an electrical circuit between the two electrodes. Current will flow from one electrode to the other through the orifice. When the cell suspension is drawn through the orifice cell will cause a resistance change which is converted to a voltage change,</p> | <p>Expl anati on:2 mark s</p> <p>Fig.: 1 mark s</p> | <p>3</p> | |

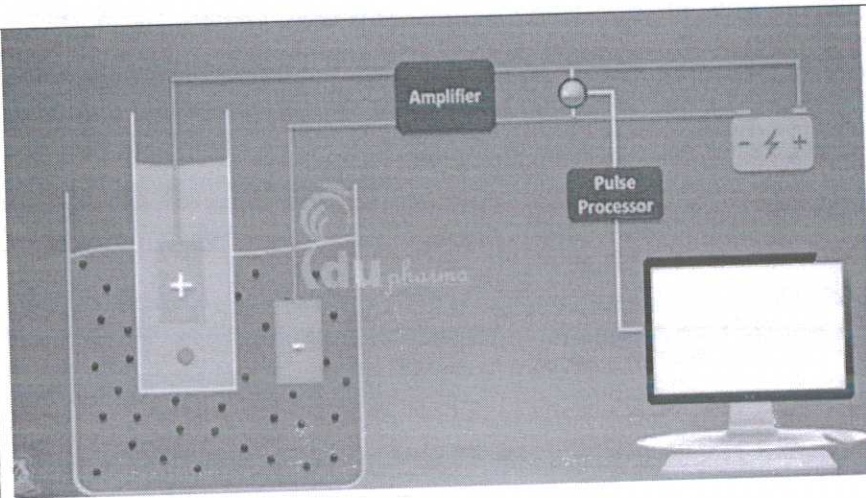

II. 6

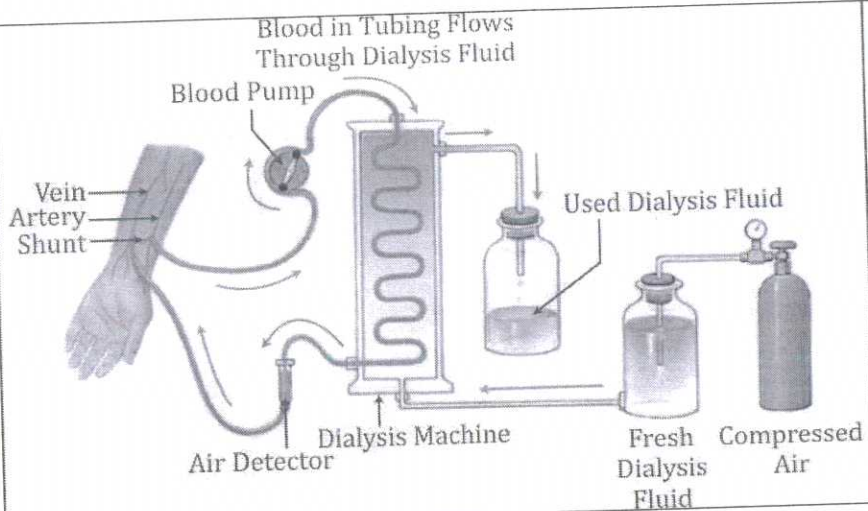

3

II. 7

| External pacemakers | Internal pacemakers |
|--|---|
| PM is placed outside the body in the form wrist notch (or in pocket) and from that one wire goes to heart through vein. | PM is miniaturized surgically implanted beneath the skin near chest or abdomen with output leads directly connected to heart muscles. |
| Endocardial electrodes applied to the heart by means of electrode catheter with electrodes tip situated in the apex of RV. These are in contact with inner surface of heart chamber. | Myocardial electrodes are in contact with outer walls of myocardium (heart muscles) endocardial electrodes are also used. |
| Does not need open chest surgery | Requires open minor surgery to place the circuit. |
| Used for temporary heart irregularities | Used for permanent heart damages. |
| Battery can be easily replaced and any defect or adjustments in the circuit can be corrected easily without consulting the doctor. | Battery can be replaced only by minor surgery. Further any defects or adjustments cannot be easily attended. It requires doctor's help. |
| During placement, swelling and pain do not rise due to minimum foreign body. | During placement swelling and pain arise due to foreign body reaction. |
| No safety for pacemaker particularly in case of children carrying the PM. | Cent percent safety for the circuit from external disturbances. |

Any four point give 3

3

II. 8

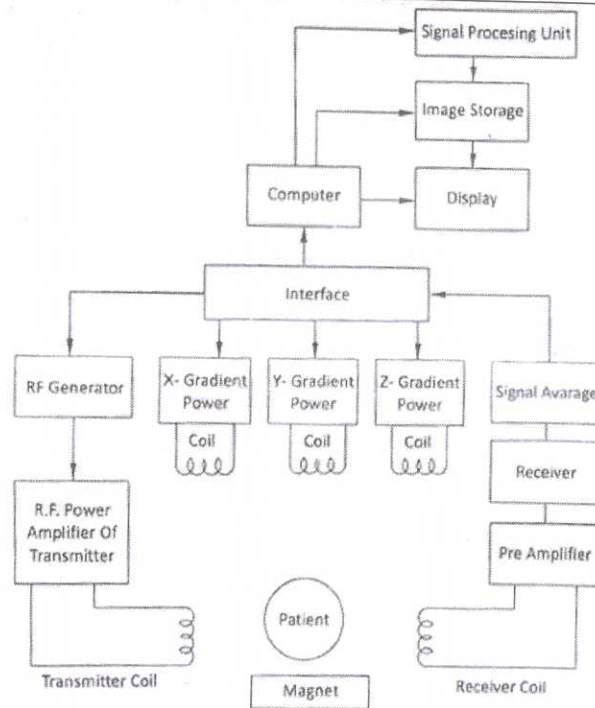

Fig. 4.5 BLOCK DIAGRAM OF MRI SIGNAL

3

II. 9

- A proper grounding system ensures that:
- Circuits have an effective return path, from the equipment to the power source
 - Low resistance is provided in order to trip or short circuit a breaker in the event of an electrical fault
 - A zero-voltage reference point is established and maintained

The Benefits of Proper Grounding

- ❖ Eliminates shock hazard
- ❖ Protects equipment from voltage
- ❖ Prevents electrical fires
- ❖ Reduces equipment repair cost and downtime
- ❖ Lowers levels of electrical noise (fluctuations in an electrical signal)

3

II. 10

Biotelemetry is a method of measuring biological parameters from a distance.

- The transmission of data from the point of generation to the point of reception can be done in various ways. We can transmit data using telephone links, or radio transmission, etc.

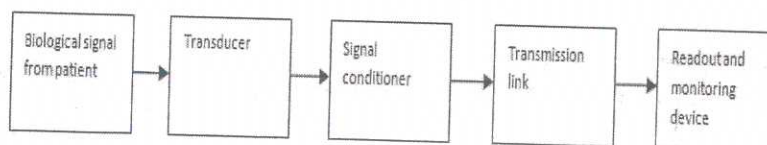

Block diagram :2

3

Explanation:1

electrodes are placed around the frontal, parietal temporal occipital lobes of the brain.

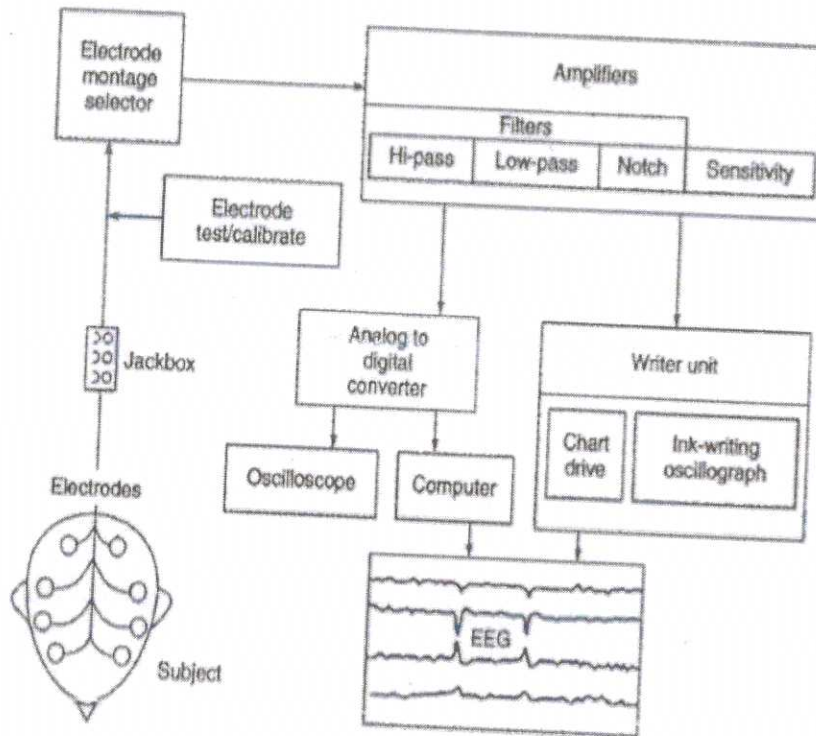

Block diagram: 4

7

V

DIRECT METHOD

□ PERCUTANEOUS INSERTION

Here a local anaesthetic is given at the desired spot. A hollow needle is inserted at a slight angle after placing the needle. A catheter is fed through the hollow needle.

□ CATHETERISATION

The catheter is a long tube that is introduced into the heart or a major vessel by way of a vein on the surface. Catheter is designed for easy travel through the blood vessels. There are two types of catheterisation techniques of direct measurement of B.P.

1. Catheter- tip blood pressure transducer.
2. Catheterisation with transducer outside the body

In the first method, the transducer is mounted at the tip of the catheter. In the other method a sterile saline solution is introduced into the catheter and the blood pressure is transferred through the fluid to a transducer placed outside the body.

□ IMPLANTATION TECHNIQUES

In this method the transducer is kept in place in the desired vessel for very long time

Period to implant the transducer a major surgery is required.

Any two: 7

7

VI

PO₂ MEASUREMENT

- A polarographic electrode system consisting of
 - a Ag/AgCl reference electrode (anode) and
 - a thin platinum wire (cathode) both immersed in an electrolyte (H₂O) and separated from the sample by a O₂ permeable membrane.
- A potential of 0.7V is applied between these electrodes. The current generated by the system is the measure of pO₂ in that sample.
- The partial pressure of a gas is proportional to the quantity of that gas present in that blood. There are two types
 - Vitro - Blood sample is taken for measurement
 - Vivo - Measurement is done while the blood is flowing

Exp
lana
tion
:3

7

Fig:
4

PO₂ MEASUREMENT

pO₂ measurement:

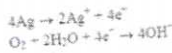
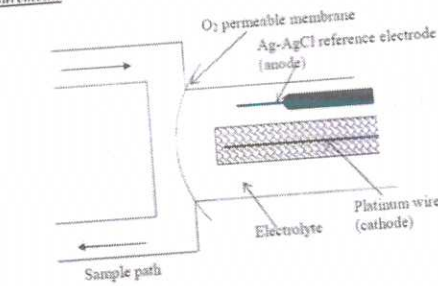

VII.

Pulse oximeters are small medical devices that have the ability to measure oxygen saturation. These devices do this by detecting how much of the hemoglobin in your blood is carrying oxygen.

Working Principle:

- ❖ Pulse Oximetry consists of Red(R) and Infrared(IR) light emitting LEDs and a photo detector.
- ❖ Oxygenated and deoxygenated hemoglobin have different light absorption rate.
 - Oxygenated hemoglobin absorbs more infrared light
 - Deoxygenated hemoglobin absorbs more red light

Prin
cipl
e:5

7

Fig:
2

Pulse oximetry uses light to measure oxygen saturation. Light beams go through your finger into a light detector on the other side

of the pulse oximeter. Some of the light beams will make it through the finger, while others will absorb into the finger.

The amount of light that the finger absorbs depends on several factors:

- The concentration of the substance that's in between the light beams and the light detector
- The length of the light path in that substance
- The amount of oxygenated hemoglobin
- The amount of deoxygenation hemoglobin

The hemoglobin in our blood absorbs light. Therefore, the amount of light that the finger absorbs is proportional to the concentration of hemoglobin in the blood.

Given that there is an artery and a vein in our finger, one has a high concentration of hemoglobin while the other has a low concentration of hemoglobin, respectively.

The length of the light path depends on the thickness of the artery in the finger. People with thicker arteries are going to absorb more light from the pulse oximeter.

Lastly, we need to cover the difference between the absorption of light in oxygenated hemoglobin and deoxygenated hemoglobin. Oxyhemoglobin absorbs more infrared light than red light, while deoxyhemoglobin absorbs more red light than infrared light.

Since red light and infrared light have different wavelengths, the finger pulse oximeter can detect how much of each wavelength the finger absorbed. Using the ratio between the absorption of red light and the absorption of infrared light, the pulse oximeter can calculate your oxygen saturation.

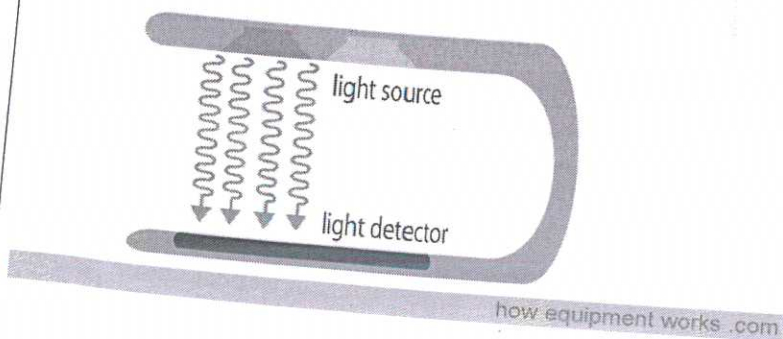

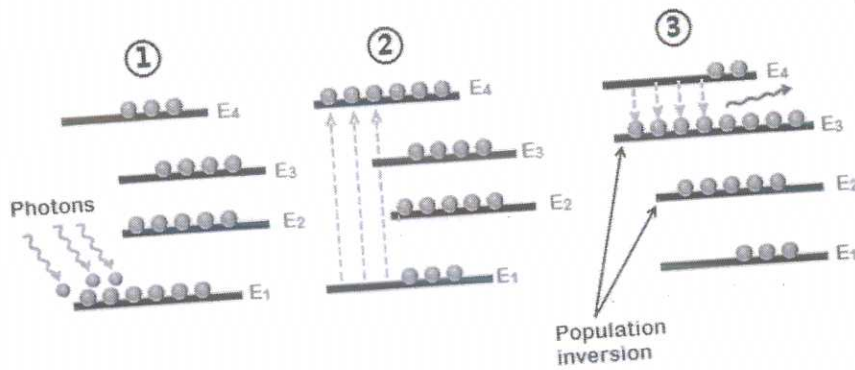

Principle: 4

7

Application: 3

(any three)

Light amplification by stimulated emission of radiation (LASER) is used as a generation of light unlike the output of conventional source of light. There are certain substances in which the electrons once excited, remain in the higher energy state for a longer period. Such systems are called active media. Such a type of materials are used to form 3 level or 4 level laser. Consider a system consisting of energy levels E_1 , E_2 and E_3 . When we supply light energy or other method, excite ground state electrons, they jump into the higher energy state E_3 . The process of supplying energy is called pumping. After a short period they quickly fall to the metastable state or energy state E_2 . The electrons in the Meta stable state E_2 will remain there for longer period. As a result large number of electrons accumulate in the Meta stable state. Thus population of Meta stable state E_2 will become greater than E_3 and E_1 . After completion of life time they fall back to E_1 by realising photons. This is process is called spontaneous emission. When this emitted photon interacts with electrons in E_2 , that electron fall back to ground state. As a result two photons are emitted. This process of emission of photon is called stimulated emission. When these photons interact with electrons in E_2 , they force two electrons to fall back to the ground state. As a result 4 photons are emitted. Likewise a large number of photons are emitted. The light generated within the laser medium will bounce back and forth between the two mirrors. One mirror will completely.

Applications of laser in Medical Field

- Treat varicose veins
- Improve vision during eye surgery on the cornea
- Repair a detached retina of the eye
- Remove the prostate
- Remove kidney stones
- Remove tumors

IX

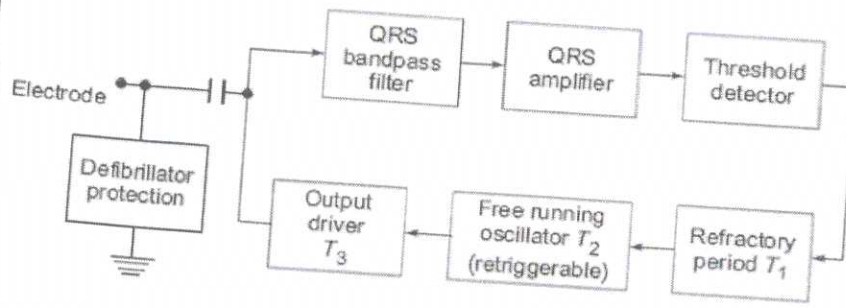

Block diagram of a ventricular synchronous demand pacemaker

Block diagram
:4

7

Patients with only short periods of AV block or bundle block can be supplied with a ventricular synchronized pacemaker.

This type of pacemaker does not compete with the normal heart activity.

Using the sensing electrode, the heart rate is detected and is given to the timing circuit in the pacemaker.

If the detected heart rate is below a certain minimum level, the fixed rate pacemaker is turned on to pace the heart.

The lead used to detect the R wave is now used to stimulate the heart.

If a natural contraction occurs, the asynchronous pacer's timing circuit

is reset so that it will time its next pulse to detect heart beat.

Otherwise the asynchronous pacemaker produces pulses at its preset rate.

Suppose the pacemaker may detect noise and interpret as its ventricular excitation, this is eliminated by the incorporation of refractory period circuit or gate circuit after either a paced or natural contraction.

its peak to peak amplitude is increased using an input filter.

Exp
lana
tion
:3

X

Microwave diathermy

It uses very short wireless waves having frequency in microwave region.

These are Electro magnetic wave with Frequency 300 to 30,000 NHZ and wavelengths Varying from 1 cm to 1 m

The most commonly used microwave frequency is 2450 MHZ with wavelength 12.25 cm.

Heating effect is produced by the absorption of the microwave in the region of the body under treatment.

The Microwave are transmitted from an emitter and are directed towards the portion of the body to be treated.

These waves pass through the intervening airspace and are

Exp
lana
tion
:3

absorbed by the surface of the body producing the heating effect

- Microwaves are high frequency waves and that are produced by special type of device called Magnetron.
- Microwave with frequency 2450 MHz penetrate 1.7cm in muscle and skin and 11.2 cm in bones.

- It Relieves the pain, reduction of Muscle spasm, increase blood supply. promote healing of open skin by Increase circulation
- Duration of treatment 20 minutes is the optimum.
- The patient should Comfortable Warmly

Fig:
4

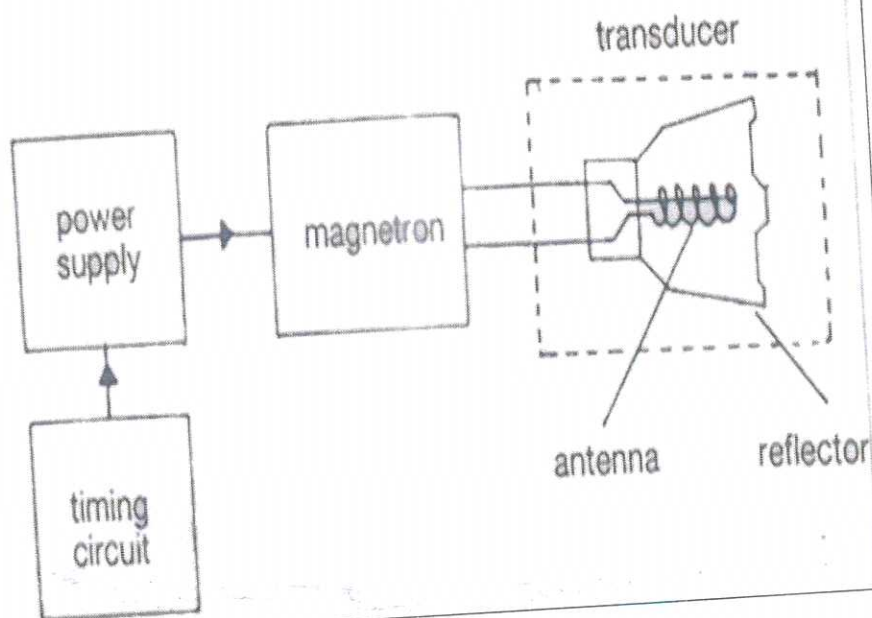

XI

Types of ventilators

Ventilators can function cylindrically i.e., during inspiration, gaseous mixture is pumped into the lungs and during expiration the pressure cases and CO₂ is exited out.

This cycle is controlled by different ways and accordingly we have;

1. **Pressure cycled ventilators:**

Inspiration is terminated when gaseous mixture or air pumped into the lungs reaches a predetermined pressure. It is simple in construction and reliable in operation.

2. **Volume cycled ventilators:**

A predetermined volume of gas is given to patient for each breathe. During inspiration a constant volume of air is sent to the lungs by applying pressure to a chamber containing known volume. Sometimes if does not give desired ventilation.

3. **Servo controlled ventilators:**

Volume and pressure regulated for each cycle by mechanical, pneumatic or electronic circuit feedback and control techniques are used to regulate the inspiration and expiration process

List
ing
type
s:2

7

Exp
lana
tion
:5

XII Defibrillator is an electronic device which gives external high energy shock to the heart muscles to stop fibrillation. Fibrillation is a cardiac emergency resulting from uncoordinated or asynchronous or irregular contraction of heart muscles. The fibrillation of atrial muscle is called atrial fibrillation and that of ventricles is called ventricular fibrillation. Ventricular fibrillation is more dangerous because under this condition ventricles are unable to pump blood. (Heart attack) and proves fatal. Fibrillation occurs due to coronary occlusion, abnormalities or electric shocks. If the heart does not recover spontaneously after delivering the shock to the heart using a defibrillator.

Ventricular fibrillation can be converted to more efficient rhythm by applying a high energy shock to the heart. The sudden cardiac arrest can be treated using a defibrillator and 80% of the patients will be cured from cardiac arrest if the treatment is given within one minute of attack .

They are used to prevent or correct an arrhythmia, an uneven heartbeat that is too slow or too fast. • If the heart suddenly stops, defibrillators can also help it beat again. • Fibrillation results from a rapid discharge of impulses from atria or ventricles. • Ventricular fibrillation is more dangerous because under this condition the ventricle unable to pump blood, this is called heart attack. • The instrument giving shock is called defibrillators. sudden cardiac arrest can be treated using a defibrillator • Based on the electrode placement these can be two types 1. Internal defibrillators 2. External defibrillators • Based on the nature of voltage applied these can be classified into 1. AC defibrillators 2. DC defibrillators

Needs:3
Explanation :4

7

XIII It is important that all Biomedical engineers and hospital staff be aware of the electrical hazards likely to occur during patient monitoring and the safety precautions necessary to prevent them. The table below summarizes the effects of a 50 Hz electric current on an average human body through the trunk (a one-second contact).

7

| Current intensity 1 Sec contact | Effect |
|------------------------------------|---|
| 1 mA | Threshold of perception. |
| 5 mA | Accepted as max harmless current intensity. |
| 10 - 20 mA | "Let-go" current before sustained muscular contraction. |
| 50 mA | Pain, possible fainting, exhaustion mechanical injury. Heart and respiration functions continue. |
| 100 - 300 mA | Ventricular fibrillation will start, but respiratory centres remain intact. |
| Greater than 6 A | Sustained myocardial contraction, followed by normal heart rhythm. Temporary respiratory paralysis. Burns are possible. |

The threshold of perception is 1mA and it varies from person to person. At this stage a faint tingling sensation is felt. At 5 mA, many sensory nerves are stimulated and the sensation becomes painful and the subject jumps away from the source of stimulation. At 10 20 mA, the Let-go current level, the muscle fibres are kept in a condition. The subject then has no ability to control his own muscle actions, and he is unable to release his grip on the electrical conductor constantly depolarized. At 100 mA, other more life threatening physiological phenomena occur like ventricular fibrillation. At about 6A or more, the heart goes into a sustained muscular contraction, but when the current ceases, the heart usually reverts to its normal coordinated mode of operation. At above 6A, massive damage is caused by the heating effect of the current flow. The voltage required to obtain these current levels is from 10 50 volts

XIV

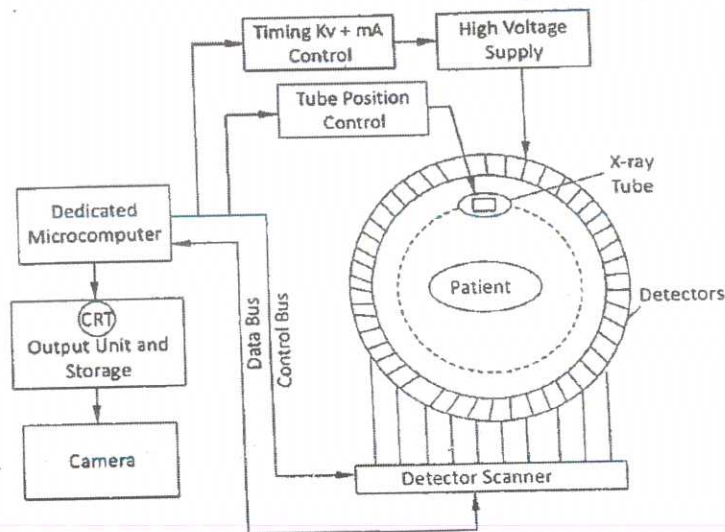

Fig:
4

7

Exp
lana
tion
:3

CT scan is x-ray procedure that creates Cross sectional Images with The helpof Computer processing CT images are more detailed than Conventional Xrays images

- o Conventional X-ray uses a fixed tube That Sends x-rays in only one direction
- o While a CT scanner uses the motorized X-ray of Source that shoots narrow beams of x-rays as it rotates around patent there are special digital x-ray detectors located directly opposite the X-ray source.
- o As the X-ray Passes through the patient they are picked up by the detectors and transmitted to a computer.
- o Images slices can enter be displayed Individually In two dimensional form or stack together to generate a 3D image.

| | | | |
|---|--|--|--|
| <p>The timing, Voltage (KV) and beam. Current (mA) are controlled by a computer through a Control bus</p> <ul style="list-style-type: none">o The high voltage DC power supply drives an x-ray tube that can be mechanically rotated through a control bus.o It is rotated along the circumference of a gantryo The patient is lying in a tube through the centre of the gantry.o The partially absorbed and the remaining more than X-ray photons 1000 radiation detectors.o The X-ray passes through the patient and are partially absorbed and the remaining x-ray photons are detected by more than 1000 radiation detectors fixed around the circumference of the gantryo The detector response is directly related to the no: of photons hit in it.o A calculation based on data obtained from a complete scan is made by the computero The output unit produces a visual image. | | | |
|---|--|--|--|