

**DIPLOMA EXAMINATION IN ENGINEERING/TECHNOLOGY/MANAGEMENT/  
COMMERCIAL PRACTICE, NOVEMBER - 2024**

**ELECTRIC CIRCUIT AND NETWORK THEORY**

[Maximum Marks : 75]

[Time : 3 hours]

**PART-A**

**I.** Answer **all** the following questions in one word or sentence. Each question carries 1 mark.

**(9x1=9 marks)**

		Module Outcome	Cognitive level
1	List various types of waveforms.	M1.01	R
2	When the frequency of AC signal is increased, inductive reactance is .....	M1.02	U
3	Super position theorem can be applied only to circuits having.....	M2.01	U
4	Write the equation of transformation ratio of a transformer is.....	M2.03	R
5	All day efficiency of a distribution transformer is.....	M2.04	R
6	Current drawn by the armature of a DC motor is directly proportional to.....	M3.02	U
7	The speed of a dc motor is inversely proportional to.....	M3.02	R
8	Frequency of alternator depends upon.....	M4.01	U
9	AC motor used in mixer grinder is.....	M4.03	R

**PART B**

**II.** Answer **any Eight** questions from the following. Each question carries 3 marks.

**(8x3=24 marks)**

		Module Outcome	Cognitive level
1	Define the terms: (i) Form factor (ii) Cycle (iii) Frequency of ac waveform	M1.01	R
2	Explain the elementary theory of transformers.	M2.03	U
3	Define (i) true power (ii) reactive power (iii) apparent power	M1.03	R
4	Explain Kirchhoff's Current Law and Kirchhoff's Voltage Law.	M2.01	U
5	Explain the significance of back emf in dc motor.	M3.02	U
6	Illustrate the speed and torque relationship of DC series motor.	M3.02	U
7	Explain the working principle of an alternator.	M4.01	U
8	Explain the effect of armature reaction in a DC generator.	M3.01	U

9	Mention the applications of autotransformer.	M2.04	R
10	State maximum power transfer theorem. Derive the condition for maximum power transfer and equation for maximum power.	M2.01	U

### PART C

Answer **all** questions from the following. Each question carries 7 marks.

**(6x7=42marks)**

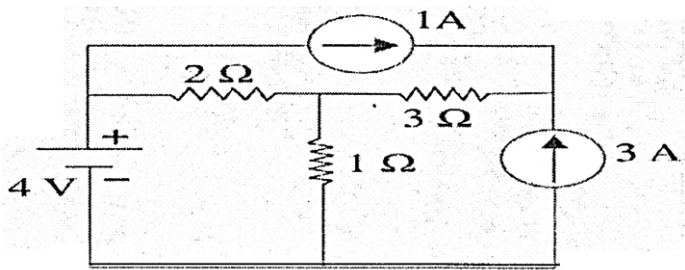
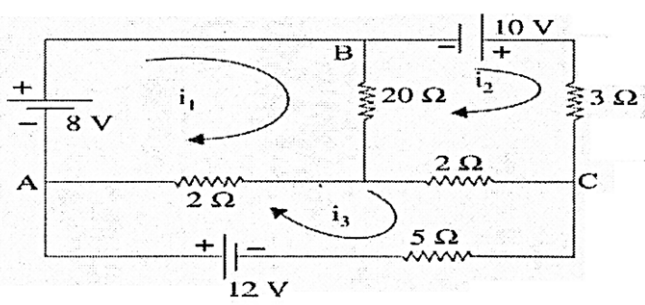
		Module Outcome	Cognitive level
III	A coil of resistance $2\Omega$ and inductance $0.01\text{ H}$ is connected in series with a capacitor across $200\text{V}$ mains. (i) What must be the capacitance in order that maximum current occurs at a frequency of $50\text{ Hz}$ ? (ii) Find the voltage across the capacitor. <b>OR</b>	M 1.04	A
IV	A coil having $50\Omega$ resistance and $0.05\text{ H}$ inductance is connected across $250\text{V}$ , $50\text{ Hz}$ supply. Calculate (a) Inductive reactance (b) Impedance (c) Current	M1.03	A
V	Explain the various types of losses in transformer. <b>OR</b>	M2.03	U
VI	Explain the construction and working principle of transformer.	M2.03	U
VII	Find the current through $1\ \Omega$ resistor using superposition theorem  	M2.02	A
VIII	Determine the current in $5\ \Omega$ resistor using mesh analysis.  	M2.02	A

IX	Derive the emf equation of DC Generator.	M3.01	U
	<b>OR</b>		
X	With neat sketches explain the operation of three point starter of dc motor.	M3.03	U
XI	Derive emf equation of an alternator.	M4.01	U
	<b>OR</b>		
XII	Explain the working principle of universal motor.	M4.03	U
XIII	With neat sketches explain the construction of single phase induction motor.	M4.04	U
	<b>OR</b>		
XIV	With the help of neat diagram explain the principle of operation of stepper motor.	M4.03	U

\*\*\*\*\*