

163

15

### Scoring Indicators

**COURSE NAME: PRINCIPLES OF ELECTRONIC COMMUNICATION**

**COURSE CODE: 3042 (21) QID: 2110220233**

Q. No	Scoring Indicators	Split Score	Sub Total	Total Score
<b>PART A</b>				<b>9</b>
I. 1	1	1	1	1
I. 2	$2(\beta+1)f_m$ ; where $\beta$ is the modulation index and $f_m$ is the maximum message frequency.	1	1	1
I. 3	$f_s < 2f_m$ ; where $f_s$ is the sampling frequency and $f_m$ is the maximum message frequency.	1	1	1
I. 4	PWM or PDM	1	1	1
I. 5	Directivity is the ratio of the radiation intensity in a direction and the radiation intensity averaged over all directions.  OR Directivity is the ratio of the radiation intensity of the antenna in a given direction and the radiation intensity of an isotropic radiator fed by the same amount of power.	1	1	1
I. 6	Pre-emphasis	1	1	1
I. 7	An unwanted signal which interferes with the original message signal and corrupts the parameters of the message signal is called as noise. Noise have no pattern and no constant frequency or amplitude.	1	1	1
I. 8	The ability to reproduce the exact replica of the transmitted signals at the receiver output is called as fidelity.  OR The ability to reproduce all the modulating frequencies of the original Information.	1	1	1

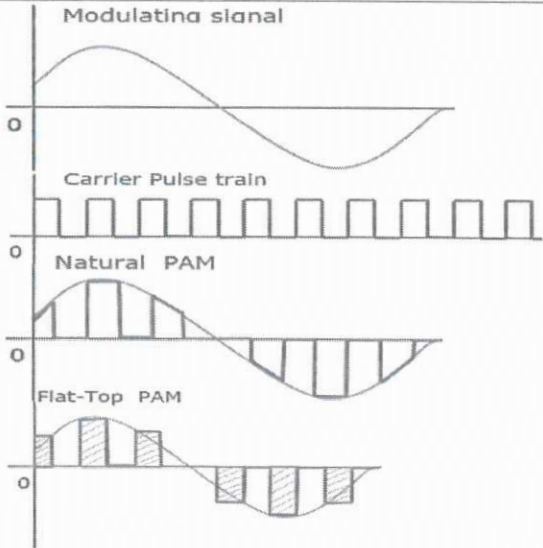

II. 03		3	3	3
II. 04	<ol style="list-style-type: none"> <li>1. Radiation intensity: The power radiated in a given direction per unit solid angle. Unit is Watts per square radian or Watt/Steradian (W/sr).</li> <li>2. Antenna Gain: The ratio of the radiation intensity in a given direction and the radiation intensity that would be obtained, if the power fed to the antenna were radiated isotropically.</li> <li>3. Antenna efficiency: The ratio of the radiated power of the antenna to the input power accepted by the antenna. Also called as Radiation efficiency factor of the antenna.</li> </ol>	$\frac{3 \times 1}{3}$	3	3
II. 05	<ol style="list-style-type: none"> <li>1. Used in global positioning satellites</li> <li>2. Used in cellular phones</li> <li>3. Used in personal communication system</li> <li>4. Used in paging devices.</li> <li>5. Used in Space craft and aircraft applications</li> <li>6. Used in radars</li> <li>7. Used in remote sensing</li> <li>8. Used in RFID.</li> <li>9. Used in medicine for the treatment of malignant tumours.</li> </ol> <p>(Any three)</p>	$\frac{3 \times 1}{3}$	3	3

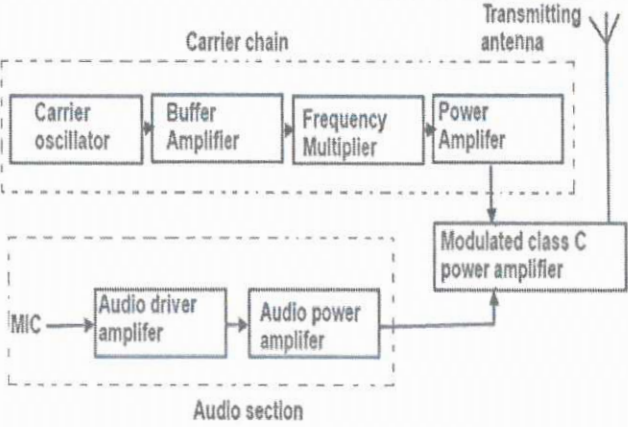
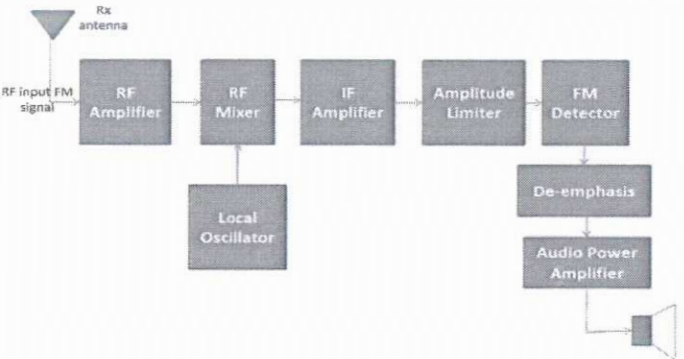
II. 06	 <p>The diagram illustrates the components of a transmitter. It is divided into two main sections: the Carrier chain and the Audio section. The Carrier chain, enclosed in a dashed box, consists of a Carrier oscillator, a Buffer Amplifier, a Frequency Multiplier, and a Power Amplifier. The Audio section, also in a dashed box, starts with a MIC (Microphone) input, followed by an Audio driver amplifier and an Audio power amplifier. The output of the Audio power amplifier is fed into a Modulated class C power amplifier, which then connects to the Power Amplifier in the Carrier chain. Finally, the Power Amplifier is connected to a Transmitting antenna.</p>	3	3	3
II. 07	<p>1. Selectivity: The ability to accept or select the desired band of frequency and reject all other unwanted frequencies (interfering signals). The signal bandwidth should be narrow for better selectivity.</p> <p>2. Sensitivity: The ability to identify and amplify weak signals at the receiver output. A receiver with good sensitivity will detect minimum RF signal at the input and still produce utilizable demodulated signal. Sensitivity is also known as receiver threshold. It is expressed in microvolts or decibels. Sensitivity of the receiver mostly depends on the gain of IF amplifier.</p>	$2 * 1.5 = 3$	3	3
II. 08	<p style="text-align: center;"><b>FM Receiver</b></p>  <p>The diagram shows the block structure of an FM receiver. It begins with an Rx antenna that receives an RF input FM signal. This signal passes through an RF Amplifier, then an RF Mixer. A Local Oscillator is connected to the RF Mixer. The signal then goes through an IF Amplifier, followed by an Amplitude Limiter, and an FM Detector. The output of the FM Detector goes through a De-emphasis stage and finally an Audio Power Amplifier, which is connected to a speaker.</p>	3	3	3
II. 09	<p>AGC/AVC is the Automatic Gain Control/Automatic Volume Control. To reduce the gain for strong signals so that the audio level is maintained for amplitude sensitive forms of modulation, and also to prevent</p>	1 (Definition)	3	3

	<p>overloading by providing a control voltage proportional to the output of the detector voltage and feedback to the base of first IF amplifier.</p> <p>Variations in the input signal strength causes the variations in the output volume of a receiver. Variations in the input signal occur when we change stations or due to fading caused by atmospheric conditions. Signals from various stations operating at the same power level may not reach the receiver antenna with the same power because of the differences in the transmission distances, carrier frequencies, atmospheric conditions and obstructions. AGC/AVC is used to limit this unwanted variations in the output volume of a receiver due to variations in the input signal strength. Hence AGC enhances the reception by automatically varying the overall gain of the receiver with the variations in the received signal strength (ie output level is constant).</p>	2 (Need)		
II. 10	<ol style="list-style-type: none"> <li>The process of extracting the original information from a modulated carrier wave is demodulation.</li> <li>Diode detector detects the envelope of the AM signal. So it is also called as envelope detector.</li> </ol>	2  1	3	3
<b>PART C</b>				<b>42</b>
III. 01	<p>Message frequency, <math>f_m = 10^3 \text{ Hz}</math>;  Carrier frequency, <math>f_c = 10^6 \text{ Hz}</math>  1. Bandwidth = <math>2 f_m = 2 \text{ kHz}</math>  Carrier amplitude, <math>A_c = 20 \text{ V}</math>  Antenna resistance, <math>R = 5 \Omega</math>  Modulation index, <math>m = 0.9</math>  Carrier power, <math>P_c = \frac{A_c \cdot A_c}{2R} = \frac{20 \cdot 20}{2 \cdot 5} = 40 \text{ W}</math>  2. Total power, <math>P_T = P_c \left(1 + \frac{m \cdot m}{2}\right) = 40 \left(1 + \frac{0.9 \cdot 0.9}{2}\right) = 56.2 \text{ W}</math></p>	1  2	7	7

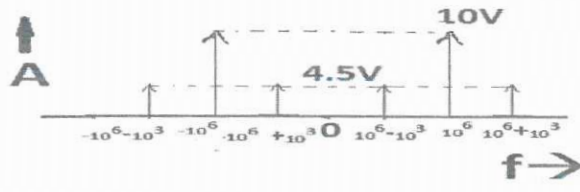
	<p>3. Modulation efficiency, <math>\eta = \frac{m \cdot m}{(m \cdot m) + 2} = \frac{0.9 \cdot 0.9}{(0.9 \cdot 0.9) + 2} = 28.82\%</math></p> 	1		
III. 02	<p>Given Frequency Sensitivity, <math>k_f = 25\text{kHz/volt}</math>; <math>A_m = 20\text{V}</math>; <math>f_c = 100\text{MHz}</math>; <math>f_m = 100\text{kHz}</math>.</p> <ol style="list-style-type: none"> <li>1. Frequency deviation, <math>\Delta f = k_f A_m = 25 \cdot 20 = 500\text{kHz}</math></li> <li>2. Modulation index, <math>\beta = \frac{\Delta f}{f_m} = \frac{500}{100} = 5</math></li> <li>3. Bandwidth = <math>2(\beta + 1) f_m = 2(5+1)100 = 1200\text{kHz}</math></li> </ol>	1 2 2 2	7	7
III. 03	<p>FM is an example for angle modulation.  Let <math>\Theta_c(t) = \omega_c t</math> be the angular function of carrier wave.  Let <math>\Theta_i(t) = \omega_i t</math> be the instantaneous angular function of FM wave.</p> $\frac{d\Theta_i(t)}{dt} = \omega_i = 2\pi f_i$ $\int \frac{d\Theta_i(t)}{dt} dt = \int 2\pi f_i dt$ <p><math>\Theta_i(t) = 2\pi \int f_i dt</math>; where <math>f_i</math> is the instantaneous frequency of FM wave.</p> <p><math>f_i = f_c + k_f m(t)</math>; where <math>k_f</math> is the frequency sensitivity of FM modulator, expressed in Hz/volt.</p> $\Theta_i(t) = 2\pi \int f_i dt = 2\pi \int [f_c + k_f m(t)] dt$ $= 2\pi \int f_c dt + 2\pi \int k_f m(t) dt$ $= 2\pi f_c t + 2\pi k_f \int m(t) dt$ <p><math>m(t) = A_m \cos 2\pi f_m t</math></p>	1 2	7	7

	$\Theta_i(t) = 2\pi f_c t + 2\pi k_f \int A_m \cos 2\pi f_m t dt$ $= 2\pi f_c t + 2\pi k_f A_m \int \cos 2\pi f_m t dt$ $= 2\pi f_c t + \frac{2\pi k_f A_m}{2\pi f_m} \sin 2\pi f_m t$ $= 2\pi f_c t + \frac{k_f A_m}{f_m} \sin 2\pi f_m t$ $= 2\pi f_c t + \beta \sin 2\pi f_m t; \text{ where } \beta \text{ is the modulation index and is } \frac{k_f A_m}{f_m}$ <p>FM wave = <math>A_c \cos \Theta_i(t)</math></p> $= A_c \cos(2\pi f_c t + \beta \sin 2\pi f_m t)$	3																													
		1																													
III. 04	<table border="1"> <thead> <tr> <th>Sl. No.</th> <th>AM</th> <th>FM</th> </tr> </thead> <tbody> <tr> <td>1.</td> <td>Carrier amplitude varies with instantaneous amplitude of message signal</td> <td>Carrier frequency varies with instantaneous amplitude of message signal</td> </tr> <tr> <td>2.</td> <td>Carrier frequency and phase will not change after modulation.</td> <td>Carrier amplitude and phase will not change after modulation.</td> </tr> <tr> <td>3.</td> <td>Requires more power. <math>P_T = P_c [1 + m^2/2]</math></td> <td>Less power <math>P_T = P_c</math></td> </tr> <tr> <td>4.</td> <td>Requires less bandwidth. (<math>2f_m</math>)</td> <td>More bandwidth. (<math>2[\beta + 1] f_m</math>)</td> </tr> <tr> <td>5.</td> <td>More susceptible to noise.</td> <td>Less susceptible to noise.</td> </tr> <tr> <td>6.</td> <td>Carrier frequency range is from 535 to 1705 kHz</td> <td>Carrier frequency range is from 88 to 108MHz</td> </tr> <tr> <td>7.</td> <td>Has poor sound quality.</td> <td>Better sound quality</td> </tr> <tr> <td>8.</td> <td>Area of coverage is more</td> <td>Area of coverage is limited to line</td> </tr> </tbody> </table>	Sl. No.	AM	FM	1.	Carrier amplitude varies with instantaneous amplitude of message signal	Carrier frequency varies with instantaneous amplitude of message signal	2.	Carrier frequency and phase will not change after modulation.	Carrier amplitude and phase will not change after modulation.	3.	Requires more power. $P_T = P_c [1 + m^2/2]$	Less power $P_T = P_c$	4.	Requires less bandwidth. ( $2f_m$ )	More bandwidth. ( $2[\beta + 1] f_m$ )	5.	More susceptible to noise.	Less susceptible to noise.	6.	Carrier frequency range is from 535 to 1705 kHz	Carrier frequency range is from 88 to 108MHz	7.	Has poor sound quality.	Better sound quality	8.	Area of coverage is more	Area of coverage is limited to line		7	7
	Sl. No.	AM	FM																												
	1.	Carrier amplitude varies with instantaneous amplitude of message signal	Carrier frequency varies with instantaneous amplitude of message signal																												
	2.	Carrier frequency and phase will not change after modulation.	Carrier amplitude and phase will not change after modulation.																												
	3.	Requires more power. $P_T = P_c [1 + m^2/2]$	Less power $P_T = P_c$																												
	4.	Requires less bandwidth. ( $2f_m$ )	More bandwidth. ( $2[\beta + 1] f_m$ )																												
	5.	More susceptible to noise.	Less susceptible to noise.																												
	6.	Carrier frequency range is from 535 to 1705 kHz	Carrier frequency range is from 88 to 108MHz																												
	7.	Has poor sound quality.	Better sound quality																												
8.	Area of coverage is more	Area of coverage is limited to line																													
		7*1 = 7																													

			of sight(LOS)			
	9.	Maximum efficiency is 33.33%	Maximum efficiency is 100%			
	10.	Transmission power varies with modulation index.	Transmission power is independent of modulation index.			
	(Any seven)					
III. 05	<p style="text-align: center;">Transmitter Section</p> <p style="text-align: center;">CHANNEL</p> <p style="text-align: center;">Receiver Section</p>			4 (Blk diag.)	7	7
	<p>PCM consists of a transmitter, a channel and a receiver. The transmitter section of a PCM consists of Sampling, Quantizing and Encoding. Sampling, Quantizing and Encoding are used for analog-to-digital conversion. The low pass filter prior to sampling prevents aliasing of the message signal. The basic operations in the receiver section are regeneration of impaired signals, decoding, and reconstruction of the quantized pulse train.</p>			3 (exp.)		
III. 06	<p>A continuous time signal or Analogue signal can be represented in its samples and can be recovered back when sampling frequency <math>f_s</math> is greater than or equal to the twice the highest frequency component of message signal <math>f_m</math>.</p> $f_s \geq 2 f_m$ <p><b>Significance</b></p> <p>To reconstruct the original analog signal we are</p>			2 (Theorem)	7	7
				1 (expression)		

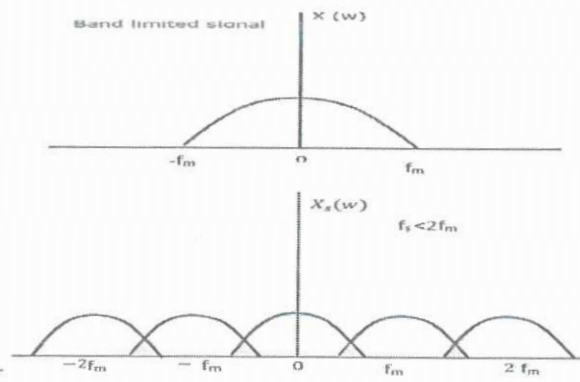
	<p>considering <math>f_s \geq 2 f_m</math>. If <math>f_s &lt; 2 f_m</math> it is called as under sampling. Under sampling results in aliasing. Aliasing is the effect in which overlapping of a frequency components takes place at the frequency higher than Nyquist rate. Distortion of signal happens due to aliasing effect. The data will be lost and cannot be recovered.</p> 	<p>2 (Signif exp.)</p>		
<p>III. 07</p>	<p>The noise suppression ability of FM decreases with the increase in the frequencies (noise has a greater effect on the higher modulating frequencies). The effect can be reduced by increasing the value of modulation index (<math>\beta</math>) for higher modulating frequencies (<math>f_m</math>). This can be done by increasing the deviation <math>\Delta f (\beta = \Delta f / f_m)</math>. <math>\Delta f</math> can be increased by increasing the amplitude of modulating signal at higher modulating frequencies. (<math>\Delta f = k_f A_m</math>). Thus, if we boost the amplitude of higher frequency modulating signals artificially then it will be possible to improve the noise immunity at higher modulating frequencies. The artificial boosting of higher modulating frequencies is called as pre-emphasis.</p> <p>Boosting of higher frequency modulating signal is achieved by using the pre-emphasis circuit. The boosting should be done before modulation in the transmitter. The pre-emphasis circuit provides a constant gain for low frequencies and at higher</p>	<p>4 (expn.)</p>	<p>7</p>	<p>7</p>

frequencies it should have a frequency characteristics of  $k|f|$ .  $k|f|$  is the frequency of a differentiator circuit or high-pass filter circuit. Hence the pre-emphasis circuit is basically a high-pass RC filter.

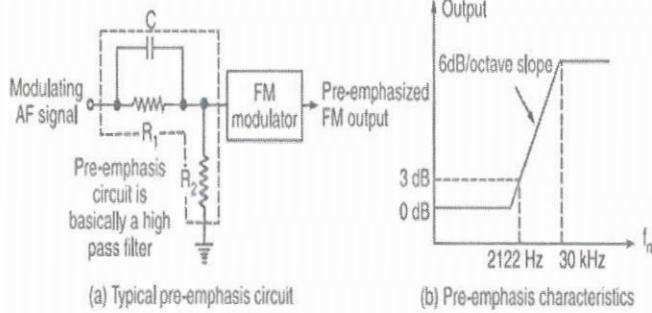

3  
(Ckt dgm.  
+  
Chara.)

The modulating signal  $m(t)$  is applied equally with  $180^\circ$  phase reversal at the inputs of both the diodes through the input center tapped transformer. The carrier is applied to the center tap of the secondary. Hence, input voltage to  $D_1$  is given by  $V_1 = \cos\omega_c t + m(t)$ . input voltage to  $D_2$  is given by  $V_2 = \cos\omega_c t - m(t)$ . The parallel RLC circuits on the output side form the band pass filters.  $i_1$  and  $i_2$  are diode currents.

$$I_1 = aV_1 + bV_1^2$$

$$I_2 = aV_2 + bV_2^2$$

III.  
08

$$i_1 = a[\cos\omega_c t + m(t)] + b[\cos\omega_c t + m(t)]^2$$

$$= am(t) + a \cos\omega_c t + bm^2(t) + 2bm(t) \cos\omega_c t + b\cos^2\omega_c t$$

$$i_2 = a[\cos\omega_c t - m(t)] + b[\cos\omega_c t - m(t)]^2$$

$$= a \cos\omega_c t - am(t) + bm^2(t) - 2bm(t) \cos\omega_c t + b\cos^2\omega_c t$$

$$i_1 - i_2 = 2am(t) + 4bm(t) \cos\omega_c t$$

The output voltage  $V_o$  is given by  $V_o = i_1 R - i_2 R = (i_1 - i_2)R$

$$V_o = 2aRm(t) + 4bRm(t) \cos\omega_c t$$

Hence, the output voltage contains a modulating signal term and the DSB-SC signal. The modulating signal

4  
(working)

7

7

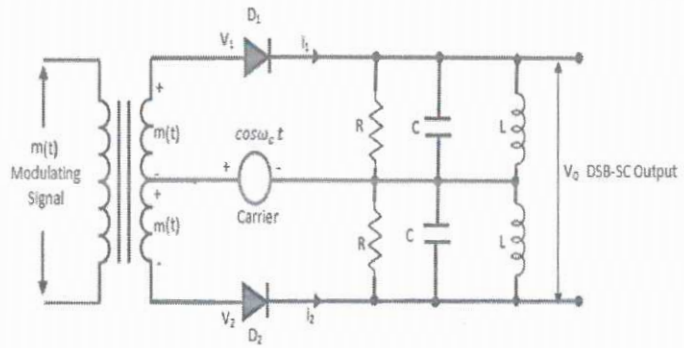
	<p>term is eliminated and the second term is allowed to pass through to the output by the LC band pass filter section .Therefore, final output is</p> $4bRm(t)\cos\omega_c t = Km(t)\cos\omega_c t \text{ where } K = 4bR$ 	3 (ckt. diag.)		
<p>III. 09</p>	<p>In transmitter before modulation the higher frequency component of message signal are boosted before modulation. So the frequency response of message signal should be return to its normal level after demodulation. For this we have to reduce the amplitude of the higher frequency component of message signal;but should not affect the lower frequency component. This is achieved by a de-emphasis circuit which have a constant gain at lower frequencies and behaves as an integrator at higher frequencies.</p> <p>The frequency characteristics mentioned above is similar to that of low pass filter. Hence de-emphasis circuit is basically a low pass filter. The process of reducing the amplitude of higher frequency components of message signal after demodulation is called as de-emphasis. De-emphasis circuit is employed after demodulator in FM receiver.</p>	4 (expn)	7	7
		3 (ckt. diag. + Chara.)		

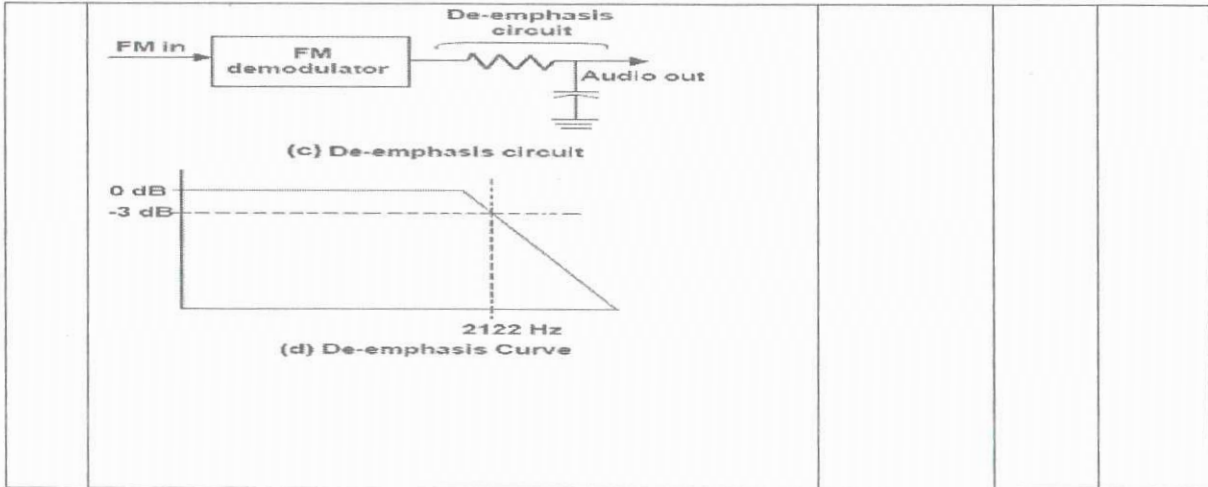

<p>III. 10</p>	<p>Noise arise from a variety of sources and can be classified as :</p> <ol style="list-style-type: none"> <li>1. External noise</li> <li>2. Internal noise</li> </ol> <p><b>1. External noise</b></p> <p>This noise is produced by the external sources which usually occur in the medium or channel of communication..The sources of external noise are :</p> <ol style="list-style-type: none"> <li>1.1 Manmade(Interference) usually from a human source</li> <li>1.2 Naturally occurring signal.</li> </ol> <p><b>1.1 Interference:</b></p> <p>Arises from electrical or electronic equipment like other communication systems(cross talk),50Hz supplies(hum) and harmonics,SMPS,thyristor circuits,ignition(car spark plugs),motors etc.</p> <p>Example: <b>Industrial Noise</b> : Sources of Industrial noise are auto-mobiles, aircraft, ignition of electric motors and switching gear. The main cause of</p>	<p>3 (Ext.noise)</p>	<p>7</p>	<p>7</p>
--------------------	--	--------------------------	----------	----------

<p>Industrial noise is High voltage wires.</p> <p><b>1.2 Naturally occurring:</b></p> <p><b>Atmospheric Noise :</b> Also known as static noise which is the natural source of disturbance caused by lightning, discharge in thunderstorm and the natural disturbances occurring in the nature.</p> <p><b>Extraterrestrial Noise :</b> Extraterrestrial Noise exist on the basis of their originating source. They are subdivided into</p> <p>i) Solar Noise:Due to radiation from sun</p> <p>ii) Cosmic Noise:Due to radiation from other heavenly bodies</p> <p><b><u>2. Internal Noise</u></b></p> <p>Noise which are generated internally or within the Communication System or in the receiver. Generated due to random movement of electrons in the electronic circuits. Internal Noises are classified as:</p> <p><b>2.1 Shot Noise :</b></p> <p>These Noise are generally arises in the active devices due to the random behaviour of charge particles or carriers.</p> <p><b>2.2 Partition Noise :</b></p> <p>When a circuit is to divide in between two or more paths then the noise generated is known as Partition noise.</p> <p><b>2.3 Low- Frequency Noise :</b></p> <p>Also known as FLICKER NOISE or pink noise or 1/f</p>	<p>4 (Int. noise)</p>		
---	---------------------------	--	--

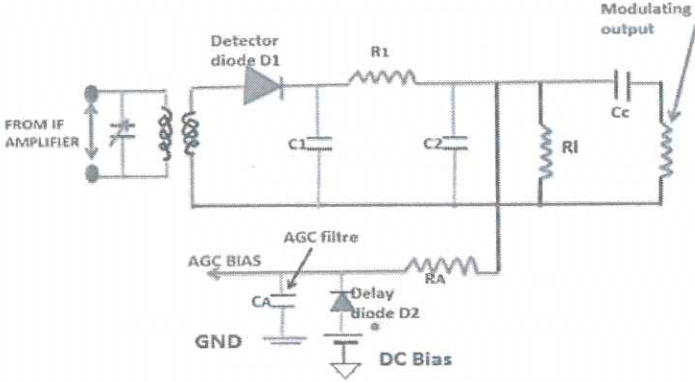
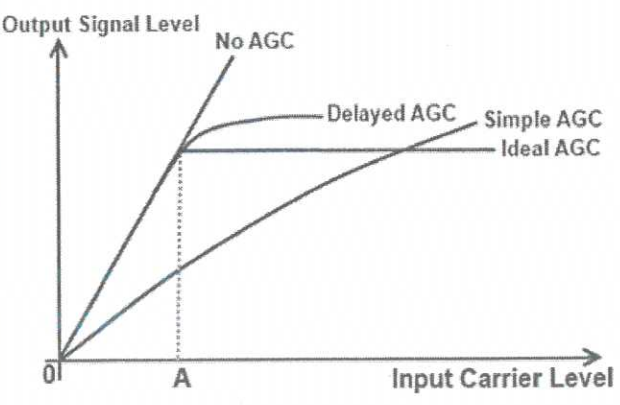

	<p>3. Instability of local oscillator.</p> <p>It is easier and less expensive to get high selectivity at a lower frequency for the same bandwidth. For the same bandwidth, a tuned circuit at a lower frequency requires low quality factor (<math>Q = f_r/BW</math>). It is easier and less expensive to get high gain at a lower frequency.</p> <p>The value of IF in FM receiver is 10.7 MHz</p>	1 (IF value)		
<p>III. 12</p>	 <p>In delayed AGC system, if the received signal strength is less than the predetermined level, it is considered as the weak signal. AGC bias is applied only after the signal has reached the predetermined level. Hence called as delayed AGC. The predetermined level is defined by a delay diode and a DC biasing. After predetermined level, AGC bias is applied like simple AGC. Hence in delayed AGC no reduction in gain for weak RF signals, but reduction in gain for strong RF signals.</p> 	<p>2 (diagram)</p> <p>3 (working)</p> <p>2 (Chara.)</p>	7	7