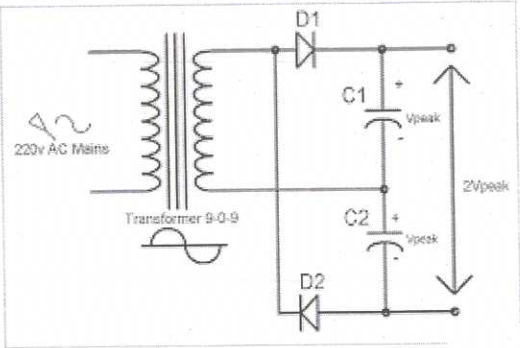
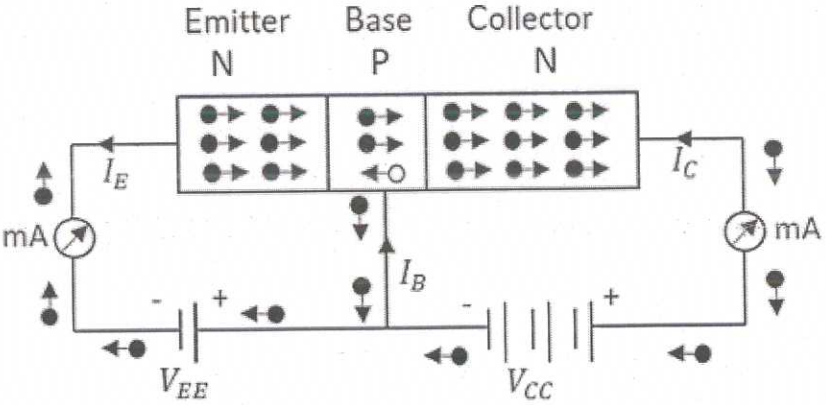
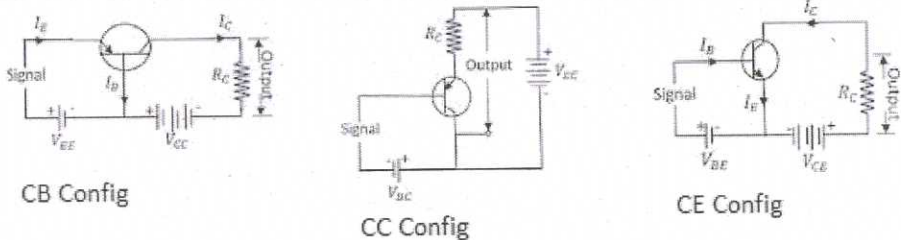

Scheme of evaluation

Course : Basic Electronics
 Version : 2015
 Code : 2041

Scoring indicators

Qn No.	Scoring indicator	Split Score	Sub total	Total
I 1	Mutual Induction is a phenomenon by which a change in current flowing through a coil will induce an e.m.f in another coil.		2	10
I 2	1 st band Brown, 2 nd band Grey, 3 rd band (Multiplier) Yellow, 4 th band or tolerance band is Gold		2	
I 3	Majority Carriers: Holes Minority Carriers : Electrons	1+1	2	
I 4	PIV is the maximum voltage the diode must withstand during the reverse bias half cycle of the input.		2	
I 5	$I_E = I_B + I_C$ Emitter current is the sum of Base current and Collector current		2	
II 1	$R_{eq} = R1 + (R2 \parallel R3) = 8 + (4 \parallel 4) = 8 + 2 = 10\Omega$ $C_{eq} = 10mF$ Series with $(5mF \parallel 5mF) = 10mF$ Series $10mF = 5mF$	3+3	6	Any 5 (5X6) =30
II 2	<p>When a p-n junction is formed, some of the free electrons in the n-region diffuse across the junction and combine with holes to form negative ions. Similarly some of the free holes in the P-region diffuse across the junction and combine with electrons to form positive ions. After a few recombination of holes and electrons a narrow width of fixed positive charges on the N-side of the junction and fixed negative charges on P-side of the junction appears. This region is known as Depletion region. Since this region has immobile ions which are electrically charged, and this barrier is setup against further movement of charge carriers and is known as potential barrier.</p> <div style="text-align: center;"> </div>	Fig (3) + Exp (3)	6	
II 3	<div style="display: flex; align-items: center;"> <div style="margin-right: 20px;"> </div> <div> </div> </div> <p>Symbol, characteristics and Explanation</p>	Symbl (1) + Chara (2) + Exp (3)	6	

II 4	<table border="1"> <thead> <tr> <th>Parameter</th> <th>Half Wave</th> <th>FW-CT</th> <th>FW Bridge</th> </tr> </thead> <tbody> <tr> <td>PIV</td> <td>V_m</td> <td>$2V_m$</td> <td>V_m</td> </tr> <tr> <td>Ripple Factor</td> <td>1.21</td> <td>0.48</td> <td>0.48</td> </tr> <tr> <td>Efficiency</td> <td>40.6%</td> <td>81.2%</td> <td>81.2%</td> </tr> <tr> <td>TUF</td> <td>0.287</td> <td>0.693</td> <td>0.812</td> </tr> </tbody> </table>	Parameter	Half Wave	FW-CT	FW Bridge	PIV	V_m	$2V_m$	V_m	Ripple Factor	1.21	0.48	0.48	Efficiency	40.6%	81.2%	81.2%	TUF	0.287	0.693	0.812	2×3=6	6	
Parameter	Half Wave	FW-CT	FW Bridge																					
PIV	V_m	$2V_m$	V_m																					
Ripple Factor	1.21	0.48	0.48																					
Efficiency	40.6%	81.2%	81.2%																					
TUF	0.287	0.693	0.812																					
II 5.	<p>Voltage multiplier configuration is known as a Full Wave Series Multiplier because one of the diodes is conducting in each half cycle, the same as for a full wave rectifier circuit. When the sinusoidal input voltage is positive, capacitor C_1 charges up through diode D_1 and when the sinusoidal voltage is negative, capacitor C_2 charges up through diode, D_2. The output voltage $2V_{IN}$ is taken across the two series connected capacitors.</p> 	Circuit (3) + Exp (3)	6																					
II 6.	 <p style="text-align: center;">Operation of a NPN transistor</p> <p>Above diagram and Explanation</p>	Fig (3) + Exp (3)	6																					
II 7.	 <p style="text-align: center;">CB Config CC Config CE Config</p>	3×2	6																					

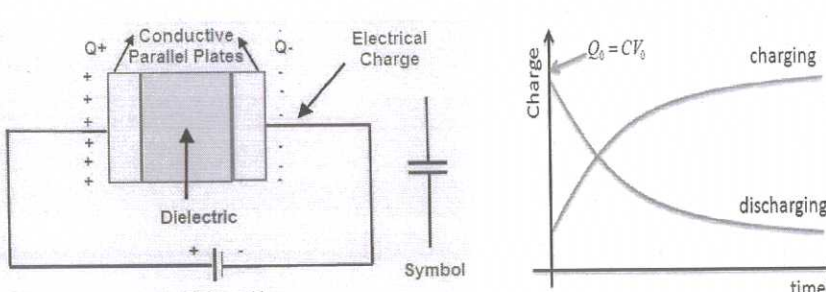
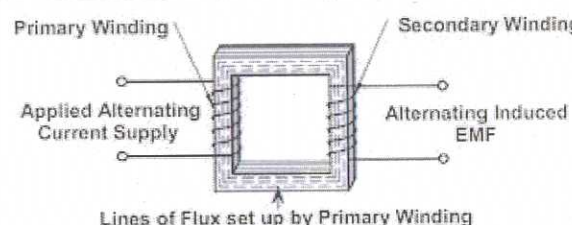
<p>III (a)</p>	 <p>Circuit Diagram, graph and explanation</p>	<p>Diag (2) + Graph (2) + Exp (4)</p>	<p>8</p>																																																									
<p>III (b)</p>	<p><u>Fixed resistors:</u> Carbon composition – General purpose Electronic Equipment. Carbon film – Measuring computers, HF Amplifiers, Telephone Circuits... Metal film – Measuring and Calibrating equipment such as CRO, Digital Multimeter etc. Wire Wound – Power electronics, current limiting & voltage dropping, etc. <u>Variable resistors:</u> Potentiometer – Volume control in audio equipment, brightness control in TV. Rheostat – Control Voltage and Current in AC and DC circuits, welding control, light dimmer, etc. Preset – Calibration and balancing electronic circuits</p>	<p>Any 4</p>	<p>7</p>	<p>15</p>																																																								
<p>IV (a)</p>	<p><u>Definition:</u> Transformer is a static device which converts electrical power from one circuit to another without changing its frequency. It Step up (or Step down) the level of AC Voltage and Current. <u>Working Principle:</u> It works on the principle of mutual induction of two coils or Faraday Law's Of Electromagnetic induction. When current in the primary coil is changed the flux linked to the secondary coil also changes. Hence an EMF is induced in the secondary coil due to Faraday law's of electromagnetic induction. <u>Turns Ratio</u> $N = N_p/N_s = V_p/V_s$</p> 	<p>Fig (3) + Exp (4) + Eqn (1)</p>	<p>8</p>	<p>15</p>																																																								
<p>IV (b)</p>	<table border="1" data-bbox="255 1422 542 1769"> <thead> <tr> <th>Color</th> <th>Digit</th> <th>Multiplier</th> <th>Tolerance (%)</th> </tr> </thead> <tbody> <tr> <td>Black</td> <td>0</td> <td>10^0 (1)</td> <td></td> </tr> <tr> <td>Brown</td> <td>1</td> <td>10^1</td> <td>-1</td> </tr> <tr> <td>Red</td> <td>2</td> <td>10^2</td> <td>2</td> </tr> <tr> <td>Orange</td> <td>3</td> <td>10^3</td> <td></td> </tr> <tr> <td>Yellow</td> <td>4</td> <td>10^4</td> <td></td> </tr> <tr> <td>Green</td> <td>5</td> <td>10^5</td> <td>0.5</td> </tr> <tr> <td>Blue</td> <td>6</td> <td>10^6</td> <td>0.25</td> </tr> <tr> <td>Violet</td> <td>7</td> <td>10^7</td> <td>0.1</td> </tr> <tr> <td>Grey</td> <td>8</td> <td>10^8</td> <td></td> </tr> <tr> <td>White</td> <td>9</td> <td>10^9</td> <td></td> </tr> <tr> <td>Gold</td> <td></td> <td>10^{-1}</td> <td>5</td> </tr> <tr> <td>Silver</td> <td></td> <td>10^{-2}</td> <td>10</td> </tr> <tr> <td>(none)</td> <td></td> <td></td> <td>20</td> </tr> </tbody> </table> <p>Table and Explanation with example</p>	Color	Digit	Multiplier	Tolerance (%)	Black	0	10^0 (1)		Brown	1	10^1	-1	Red	2	10^2	2	Orange	3	10^3		Yellow	4	10^4		Green	5	10^5	0.5	Blue	6	10^6	0.25	Violet	7	10^7	0.1	Grey	8	10^8		White	9	10^9		Gold		10^{-1}	5	Silver		10^{-2}	10	(none)			20	<p>Table (3) + Exp (4)</p>	<p>7</p>	
Color	Digit	Multiplier	Tolerance (%)																																																									
Black	0	10^0 (1)																																																										
Brown	1	10^1	-1																																																									
Red	2	10^2	2																																																									
Orange	3	10^3																																																										
Yellow	4	10^4																																																										
Green	5	10^5	0.5																																																									
Blue	6	10^6	0.25																																																									
Violet	7	10^7	0.1																																																									
Grey	8	10^8																																																										
White	9	10^9																																																										
Gold		10^{-1}	5																																																									
Silver		10^{-2}	10																																																									
(none)			20																																																									

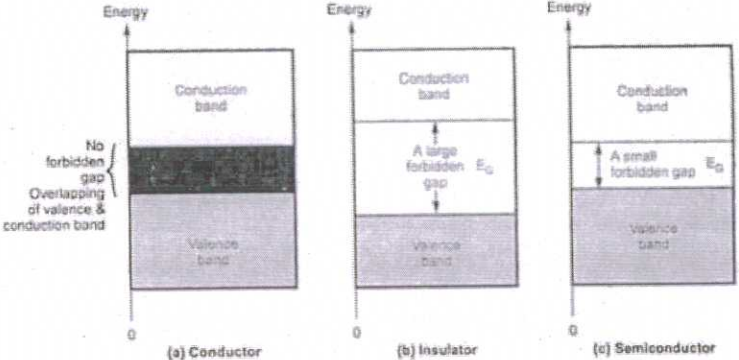
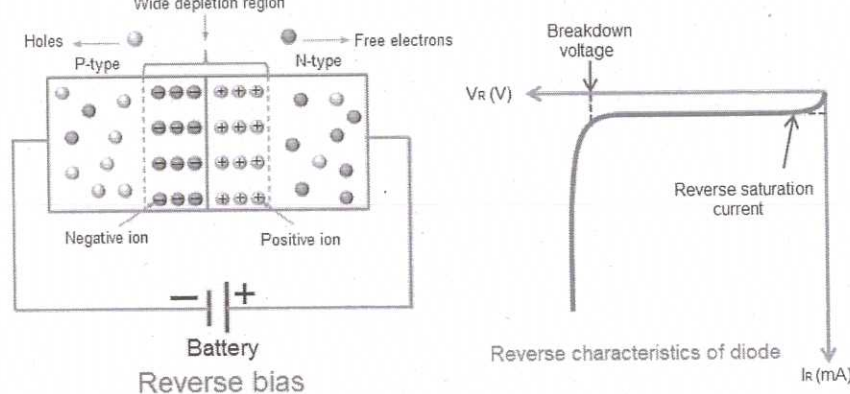
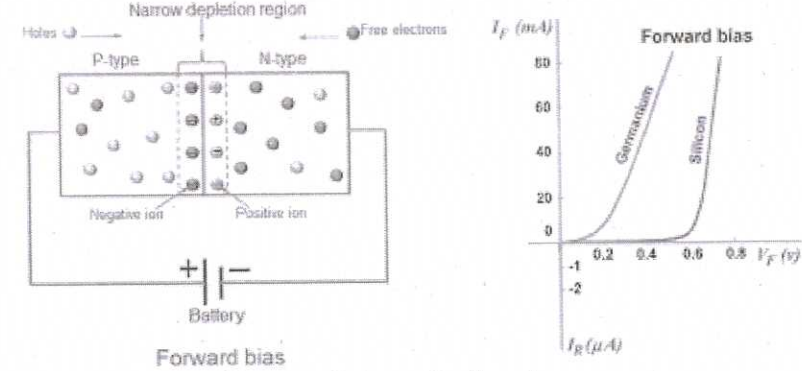
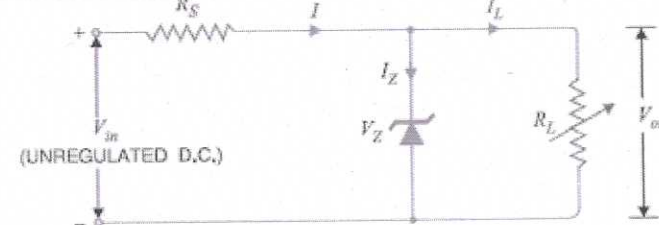
<p>V (a)</p>	 <p>Energy</p> <p>Conduction band</p> <p>Valence band</p> <p>No forbidden gap Overlapping of valence & conduction band</p> <p>(a) Conductor</p> <p>(b) Insulator</p> <p>(c) Semiconductor</p> <p>Energy Gap, E_g for Insulators $>5eV$, for Semiconductors $=1eV$</p> <p>Band Diagram + Explanation + E_g Value (Insulators and Semiconductors)</p>	<p>Cond (2) + SC (3) + Ins(3)</p>	<p>8</p>	<p>15</p>
<p>V (b)</p>	 <p>Wide depletion region</p> <p>Holes</p> <p>Free electrons</p> <p>P-type</p> <p>N-type</p> <p>Negative ion</p> <p>Positive ion</p> <p>Battery</p> <p>Reverse bias</p> <p>Breakdown voltage</p> <p>Reverse saturation current</p> <p>Reverse characteristics of diode</p> <p>V_R (V)</p> <p>I_R (mA)</p> <p>Diag (2) + chara (2) + Exp (3)</p>	<p>Diag (2) + chara (2) + Exp (3)</p>	<p>7</p>	<p>15</p>
<p>VI (a)</p>	 <p>Narrow depletion region</p> <p>Holes</p> <p>Free electrons</p> <p>P-type</p> <p>N-type</p> <p>Negative ion</p> <p>Positive ion</p> <p>Battery</p> <p>Forward bias</p> <p>Forward bias</p> <p>Germanium</p> <p>Silicon</p> <p>I_F (mA)</p> <p>V_F (V)</p> <p>Diag (2) + Chara (3) + Exp (3)</p>	<p>Diag (2) + Chara (3) + Exp (3)</p>	<p>8</p>	<p>15</p>
<p>VI (b)</p>	 <p>R_S</p> <p>I</p> <p>I_L</p> <p>I_Z</p> <p>V_Z</p> <p>R_L</p> <p>V_{out}</p> <p>V_{in} (UNREGULATED D.C.)</p> <p>$I = I_Z + I_L$</p> <p>Circuit diagram + Explanation</p> <p>Diag (3) + Exp (4)</p>	<p>Diag (3) + Exp (4)</p>	<p>7</p>	<p>15</p>

VII (a)	<p>Circuit Diagram + Waveforms + Explanation</p>	Diag (2) + WF (3) + Exp (3)	8	
------------	--	---	---	--

VII (b)	<p>Clippers are the circuits used to change the shape of an input signal by removing (clipping) a portion of it without alerting the remaining part of the wave. Clipping circuit that use diode are known as diode clippers.</p> <p>Series Clipper: Diode connected in series with the input</p> <p>Shunt Clipper: Diode is connected in parallel and output is taken across the diode.</p> <p>Positive Clipper: Clipper circuit that removes the portion of positive half cycle of the input</p> <p>Negative Clipper: Clipper circuit that removes the portion of negative half cycle of the input.</p> <p style="text-align: center;">Shunt positive clipper with positive bias</p> <p>During the positive half cycle, the diode is forward biased by the input supply voltage V_i and reverse biased by the battery voltage $V_B = +3V$. However, initially, the input supply voltage V_i is less than the battery voltage V_B. Hence, the battery voltage V_B makes the diode to be reverse biased. Therefore, the signal appears at the output. However, when the input supply voltage V_i becomes greater than the battery voltage V_B, the diode D is forward biased by the input supply voltage V_i. As a result, no signal appears at the output.</p> <p>During the negative half cycle, the diode is reverse biased by both input supply voltage and battery voltage. So it doesn't matter whether the input supply voltage is greater or lesser than the battery voltage, the diode always remains reverse biased. As a result, a complete negative half cycle appears at the output.</p>	Clipper Ckts (4) + Diag (1) + Exp (2)	7	15
------------	---	--	---	----

Half wave Rectifier Working: During the positive half cycle the diode is under forward bias condition and it conducts current to R_L (Load resistance). A voltage is developed across the load, which is same as the input AC signal of the positive half cycle.

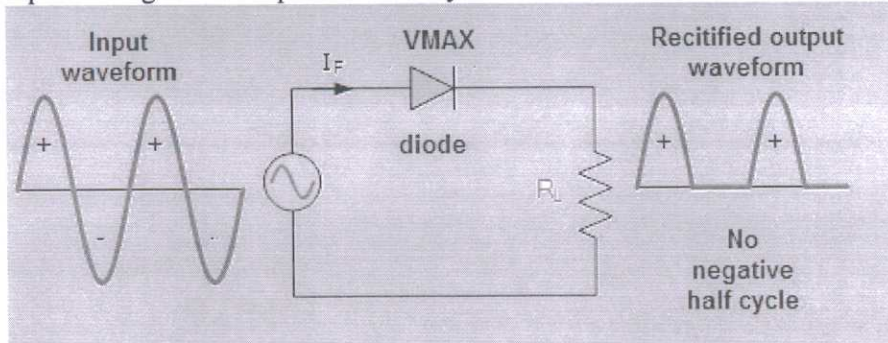

Alternatively, during the negative half cycle the diode is under reverse bias condition and there is no current flow through the diode. Only the AC input voltage appears across the load and it is the net result which is possible during the positive half cycle. The output voltage pulsating DC voltage.

VIII
(a)

Exp
(4) +
Diag +
WF (4)

8

A clamper is an electronic circuit that changes the DC level of a signal to the desired level without changing the shape of the applied signal. A clamper circuit adds the positive dc or negative dc component to the input signal to push it to the positive side or negative side respectively.

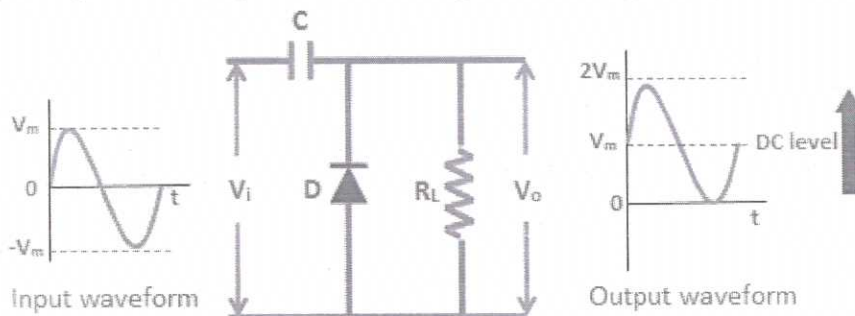

Positive clamper

If the circuit pushes the signal upwards then the circuit is said to be a positive clamper. When the signal is pushed upwards, the negative peak of the signal meets the zero level.

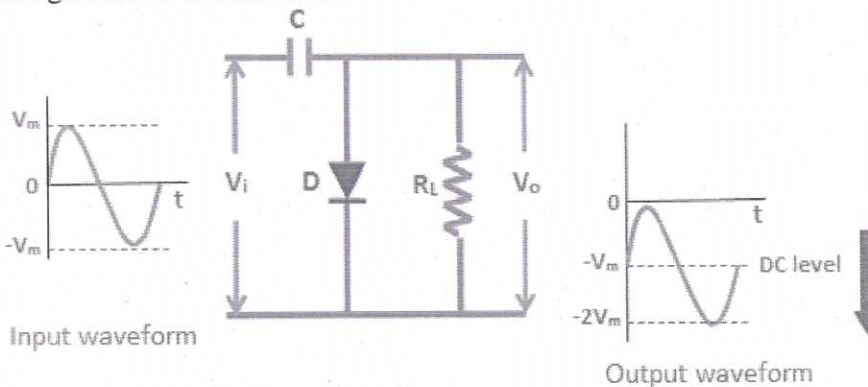

Negative clamper

On the other hand, if the circuit pushes the signal downwards then the circuit is said to be a negative clamper. When the signal is pushed downwards, the positive peak of the signal meets the zero level.

VIII
(b)

Intro
(1) +
exp
(2×3=6)

7

15

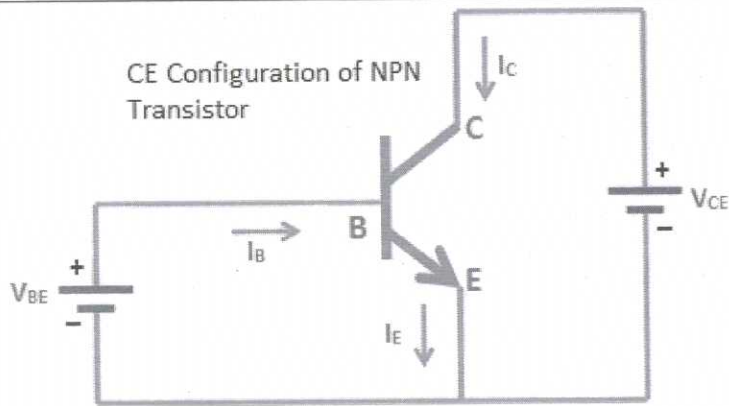

In common emitter configuration, base is the input terminal, collector is the output terminal and emitter is the common terminal for both input and output. The input signal is applied between the base and emitter terminals while the output signal is taken between the collector and emitter terminals. Thus, the emitter terminal of a transistor is common for both input and output and hence it is named as common emitter configuration.

Output characteristics

The output characteristics describe the relationship between output current (I_C) and output voltage (V_{CE}), at constant input current (I_B).

IX
(a)

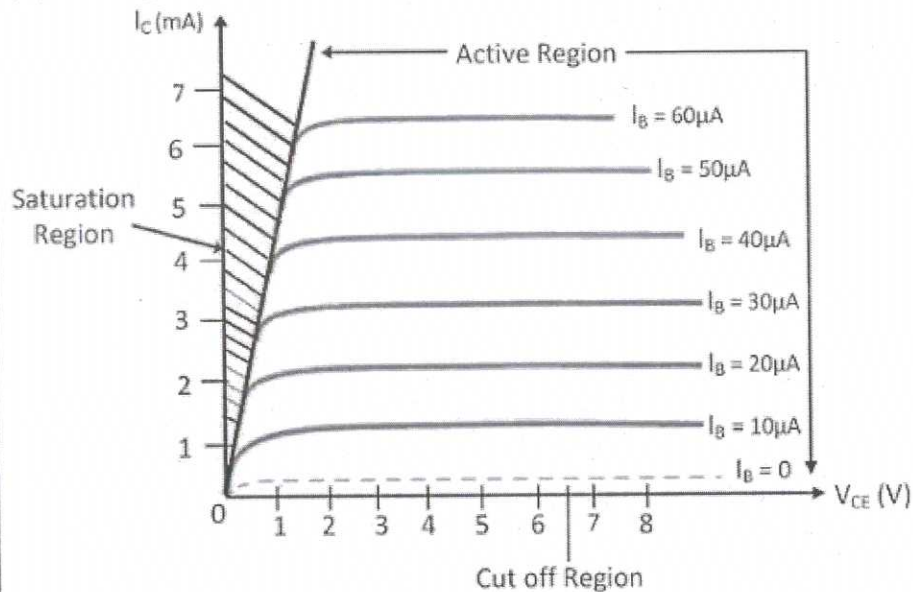

Output Characteristic Curve

Circuit Globe

Ckt
diag
(2) +
Chara
(2) +
Region
(3) +
exp (3)

10

15

Relationship between α_{dc} and β_{dc}

For an NPN transistor

$$I_E = I_B + I_C$$

Dividing each term by I_C we get

$$\frac{I_E}{I_C} = \frac{I_B}{I_C} + \frac{I_C}{I_C}$$

or

$$\frac{I_E}{I_C} = \frac{I_B}{I_C} + 1$$

$$\frac{1}{\alpha_{dc}} = \frac{1}{\beta_{dc}} + 1$$

$$\frac{1}{\alpha_{dc}} = \frac{1 + \beta_{dc}}{\beta_{dc}}$$

$$\alpha_{dc} = \frac{\beta_{dc}}{1 + \beta_{dc}}$$

Similarly, we can prove that

$$\beta_{dc} = \frac{\alpha_{dc}}{1 - \alpha_{dc}}$$

IX
(b)

5

α_{dc} and β_{dc} can be read as α and β respectively

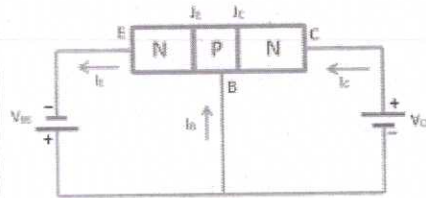
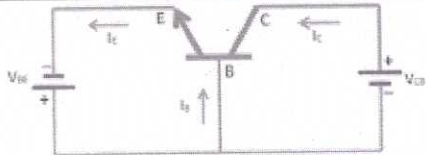

Common base configuration

Any one circuit diagram

X
(a)

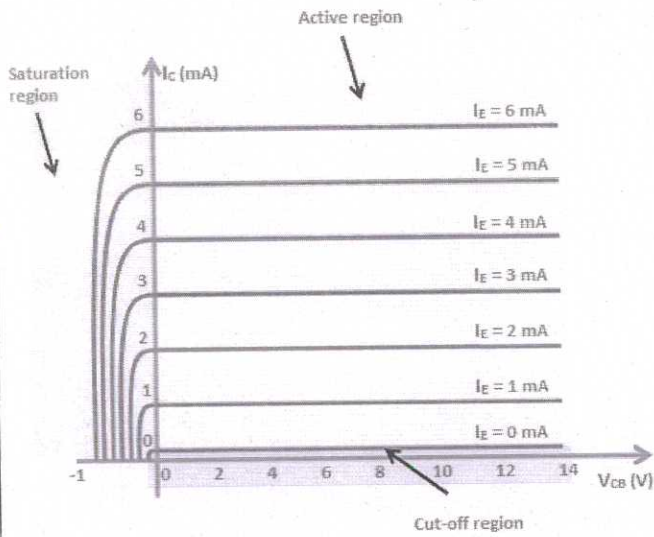

O/P characteristics CB configuration

Ckt (2)
+ chara
(3) +
Exp
(4)

9

15

X
(b)

Parameter	CB	CE	CC
Input Resistance	Low	Moderate	High
Output Resistance	High	Moderate	Low
Current Gain	Less than unity (0.98)	High (>100)	High (>100)

2×3

6