



SCHEME OF VALUATION

(Scoring Indicators)

Qst No	Scoring indicator	Split up score	Sub Total	Total
Revision: 2015 Course Code: <u>3022</u>				
Course Title: <u>FLUID MECHANICS & PNEUMATICS</u>				
I	PART - A			
1	The intensity of pressure at any point in a liquid at rest is the same in all directions.	2		2
2	Specific gravity is the ratio of the specific weight of liquid to the specific weight of a standard fluid	2		2
3	Venturimeter, Pitot tube	2x 1	2	2
4	To act as a Pressure compensator, To maintain steady delivery pressure, It act as a shock absorber	2		2
5	Pressure Guage -  Check valve- 	2 x 1	2	2
	PART - B			
1	Absolute Pressure - When the pressure is measuring relative to the absolute zero pressure or it is the sum of gauge pressure and atmospheric pressure. Gauge pressure - The pressure measuring with the help of a pressure measuring instrument relative to atmospheric pressure Vacuum Pressure - The pressure of the fluid measuring below the atmospheric pressure or it is the difference between atmospheric pressure and absolute pressure.	3 x 2	6	6
	LIMITATIONS OF BERNOULLI'S THEOREM			
2	1. The assumptions that the velocity of liquid particle across any cross section of pipe is uniform, is not practical. In actual practice, the velocity of liquid particle in the centre of a pipe is maximum and gradually decreases towards the walls of the pipe due to friction. 2. The assumption that two external forces except the gravity acts on the liquid is also non-practical. There are always some external forces like pipe friction etc. acts on the liquid and affects its flow.			6

	<p>3. Another assumption is that there is no loss of energy of the liquid particle while flowing. But in turbulent flow, some kinetic energy is converted into heat energy and in viscous flow some energy is lost due to shear forces.</p> <p>4. Bernoulli's theorem does not taken into account, the energy due to centrifugal forces for a liquid flowing in a curved path.</p>	4x1.5	6	6
3	<p><u>HYDRAULIC GRADIENT LINE (H.G.L) :</u></p> <p>The line joining the sum of the pressure head and datum head $[P/w+ Z]$ plotted along the length of the pipe line is known as Hydraulic gradient line or piezometric head line. It is denoted by H.G.L.</p> <p>For a horizontal pipe the hydraulic gradient line is equal to the slope of line joining the pressure head along the length of the pipe line. If the pipe is inclined then the hydraulic gradient line is equal to the slope of line joining the sum of pressure head and datum head.</p> <p><u>Total Energy Line (T.E.L) :</u></p> <p>The line joining sum of the pressure head, datum head and velocity head $[P/w+Z+V/2g]$ plotted along the length of the pipe is known as Total energy line. It is denoted by T.E.L</p> <p>For a horizontal pipe the total energy line is equal to the slope of the pressure head, velocity head along the length of pipe line. If the pipe is inclined the total energy line is equal to the slope of line joining the sum of pressure head, velocity head and datum head.</p>	3 x 2	6	6
4	<p>a) Viscosity</p> <p>b) Oxidation stability</p> <p>c) Demulsibility</p> <p>d) Lubricity</p> <p>e) Pour point</p> <p>f) Flash point</p> <p>g) Fire Point</p> <p>h) Neutralisation Number.</p>	6x1	6	6
5	<p>Solenoid valve is an electromagnetic valve used to actuate the main valve. The passage is shown closed by the plunger in a normal closed position. When electric supply is given to the coil, the coil gets magnetically energized and pulls up the plunger against a spring force. Now the passage is open and compressed air flows from supply end to the cylinder port.</p>			

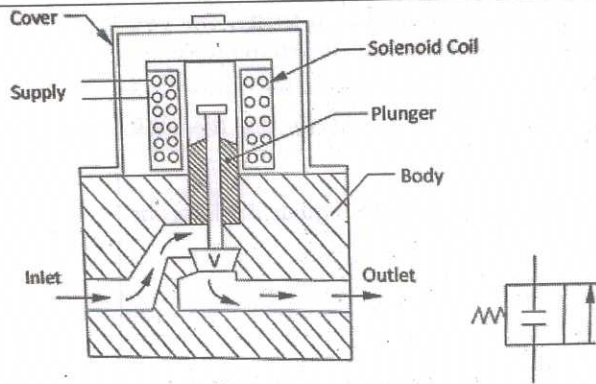

6

- In mining, ore and mineral extraction
- Wood processing and paper industry
- Steel mills and forging presses
- In dams lifting and lowering of the gates
- Transport, road vehicles, rail, shipping etc
- All earth moving machinery
- Mobile drill jigs
- Defence applications
- Construction equipments

Fig-3
Exp-3

6

6

(Any
6)

1x6

6

6

7

A duplex cylinder is made up of two cylinders mounted in line with piston not connected and with rod seals installed between the cylinders to permit double acting operations of each. These cylinders are used where two operations performed in a sequence such as clamping or unclamping a work, one piston clamps the workpiece while the other performs another operation. The figure shows a duplex cylinder with two pistons and two piston rods.

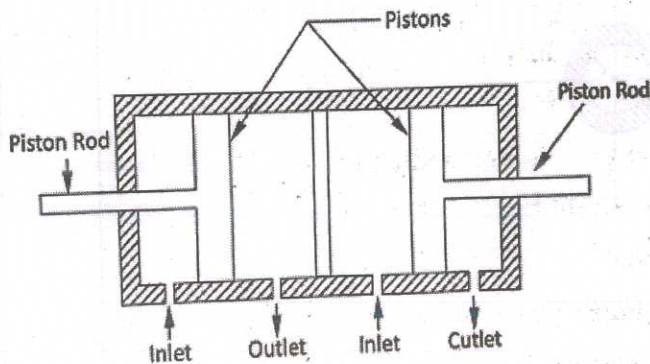

Exp-3

Fig-3

6

III a)

U- Tube differential manometer consist of glass tube bent in u shape, the two ends of which are connected to the two gauge points between which the pressure difference is to be measured. The lower part of the manometer contains a manometric liquid which is heavier than the liquid for which the pressure difference is to be measured.

Let the two pipes A and B at a different levels and contains liquids of different specific gravity as shown in fig.

Let P_A = pressure in pipe A

P_B = Pressure in pipe B

h_1 = Distance of the centre of A from mercury level in the left limb

S_1 = Specific gravity of liquid in pipe A

h_2 = Difference of mercury level in pipe A

S_2 = Specific gravity of mercury

h_3 = Distance of the centre of B from mercury level in right limb

S_3 = Specific gravity of liquid in pipe B

As the pressure head is the same for horizontal surface. Hence the pressure head above the datum Z-Z in the left limb equal to pressure head above the datum Z-Z in the right limb

$$\frac{P_A}{w} + S_1 h_1 = \frac{P_B}{w} + S_2 h_2 + S_3 h_3$$

$$\frac{P_A - P_B}{w} = S_2 h_2 + S_3 h_3 - S_1 h_1 \text{ m of water}$$

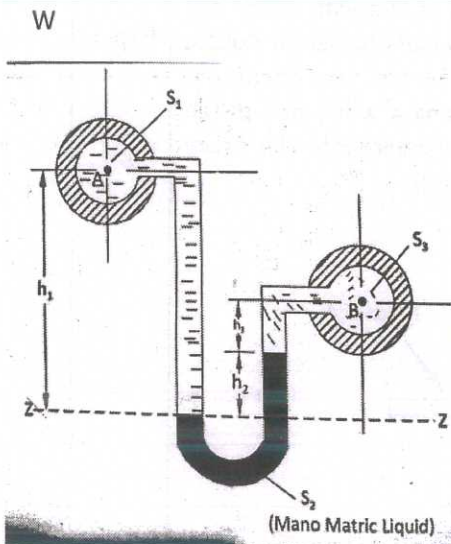
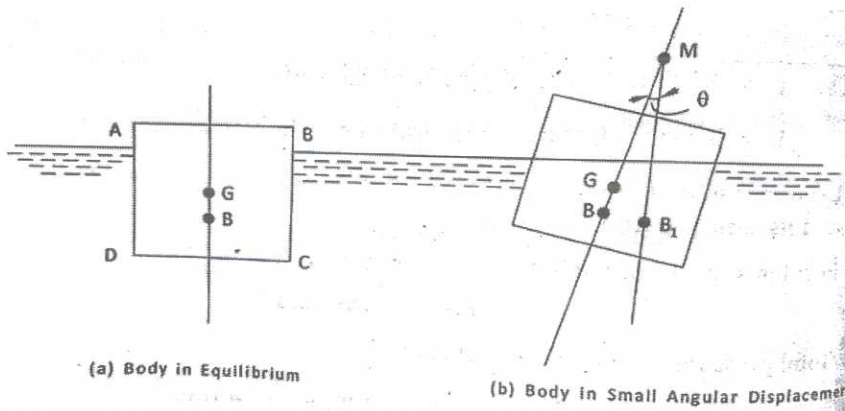

Fig-3

Expl-5

<p>III b)</p>	<p>Given Data,</p> <p>Volume of liquid, $V = 5.27 \text{ m}^3$</p> <p>Weight of liquid, $W = 44 \text{ kN} = 44 \times 10^3$</p> <p>Specific weight, $w = \frac{\text{weight of liquid}}{\text{Volume of liquid}}$</p> <p>$= \frac{44 \times 10^3}{5.27} = 8349.15 \text{ N/m}^3 \text{ (Ans)}$</p> <p>Density = $\frac{\text{mass of liquid}}{\text{Volume of liquid}}$</p> <p>$= \frac{8349.15}{9.81} = 851 \text{ kg/m}^3 \text{ (Ans)}$</p> <p>Specific gravity = $\frac{\text{Density of liquid}}{\text{Density of water}}$</p> <p>$= \frac{851}{1000} = 0.85 \text{ (Ans)}$</p>	<p>1</p> <p>Ans- 3x2</p>	<p>6</p>	<p>7</p>
<p>IV a)</p>	<p>Given Data,</p> <p>$b = 2 \text{ m}, d = 3 \text{ m}$</p> <p>$x = \text{Distance of C. G. from the free surface of water}$</p> <p>$= 2.5 + 3/2 = 4 \text{ m}$</p> <p>Total Pressure, $P = w A x$</p> <p>w - Specific weight of water = 9810 kN/m^3</p> <p>$A = b \times d = 3 \times 2 = 6 \text{ m}^2$</p> <p>$P = 9810 \times 6 \times 4 = 235440 \text{ N} = 235.44 \text{ kN (Ans)}$</p>	<p>8</p>	<p>8</p>	<p>8</p>
<p>IV b)</p>	<p>Metacentre</p> <p>Metacentre is a point about which a floating body starts oscillating, when given a small angular displacement. It is denoted by M</p> <p>Metacentric Height</p> <p>Metacentric height is the distance between the centre of gravity of the floating body and the metacentre.</p>	<p>Fig-3</p> <p>Exp- 2x2</p>	<p>3</p> <p>4</p>	<p>7</p>



v a)

VENTURIMETER

A Venturimeter is a device for measuring discharge or rate of flow of fluid flowing in a pipe. It consists of three compartments.

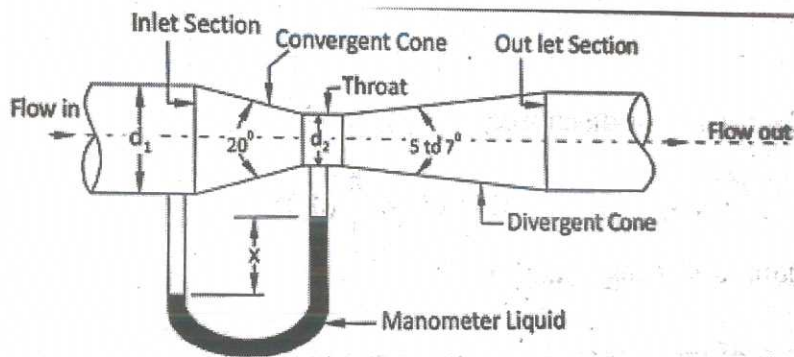

Fig-3

Exp-5

1 Convergent cone

2 Throat

3 Divergent cone

1. **Convergent cone** : It is a short taper pipe which converges from the pipe diameter to throat diameter. The velocity of fluid increases as it passes through the convergent section and there is full in pressure. The angle of the convergent varies from 20° to 22° .
2. **Throat** : It is a short circular pipe in which the diameter is kept constant. At this section the velocity is maximum and the pressure is minimum. The throat diameter is usually $1/2$ to $1/4$ of inlet diameter and the length of throat is equal to its diameter.
3. **Divergent Cone** : It is a tapered pipe of gradually diverging (increasing) cross sectional area from that of throat to the original size of the pipe. The divergent cone is also known as outlet of venturi meter. The angle of divergent cone varies from 5° to 7° .

According to continuity equation the increase in velocity result in decrease in

<p>v b)</p>	<p>pressure at this section. As a result the pressure difference is developed between inlet and throat sections. This pressure difference can be determined by connecting a manometer between inlet and throat as shown in Figure.</p> <p>Given data, Pressure , $P = 4 \text{ bar} = 4 \times 10^5$ Velocity, $V = 5 \text{ m/sec}$ Assume ground level as datum, $Z = 10 \text{ m}$ Total Head , $H = \frac{P}{\rho g} + \frac{V^2}{2g} + Z$ $= \frac{4 \times 10^5}{9810} + \frac{5^2}{2 \times 9.81} + 10$ $= 52 \text{ m of water /kg.}$ Total energy = $52 \times 3 = 156 \text{ m of water} = 156 \times 9.81 = 1530 \text{ N-m (Ans)}$</p>	7	7	7
<p>v i a)</p>	<p>Given data, Diameter at inlet, $d_1 = 30 \text{ cm} = 0.3 \text{ m}$ Area at inlet , $a_1 = \frac{\pi}{4} \times (0.3)^2 = 0.0707 \text{ m}^2$ Diameter at throat, $d_2 = 15 \text{ cm} = 0.15 \text{ m}$ Area at outlet , $a_2 = \frac{\pi}{4} \times (0.15)^2 = 0.0176 \text{ m}^2$ Differential manometer reading , $h = 20 \text{ cm} = 0.2 \text{ m}$ Theoretical Discharge $Q_{th} = \frac{a_1 a_2}{\sqrt{a_1^2 - a_2^2}} \times \sqrt{2gh}$ $= \frac{(0.0707) \times (0.0176)}{\sqrt{(0.0707^2 - 0.0176^2)}} \times \sqrt{2 \times 9.81 \times 0.2}$ $= 0.036 \text{ m}^3/\text{sec}$ Actual Discharge , $Q_{act} = C_d \times Q_{th}$ $= 0.98 \times 0.036 = 0.0353 \text{ m}^3/\text{sec (Ans)}$</p>	8	8	8
<p>v i b)</p>	<p>TYPE OF FLUID FLOW</p> <p>According to different considerations fluid flow may be classified as following ways.</p> <ol style="list-style-type: none"> 1. Steady flow : A flow is said to be steady during which the fluid characteristics like pressure, density, velocity, acceleration etc., at any points does not change with time. 	(Any 7)	1x7	7

2. Unsteady flow : A fluid is said to be unsteady during which the fluid characteristics like velocity, pressure, density, acceleration etc., at any point changes with time.
3. Uniform flow : A uniform flow is defined as that type of flow in which the velocity of flow of fluid does not change in magnitude and direction from point to point in the flowing fluid for a given instant of time.
4. Non-uniform flow : A Non-uniform flow is defined as that type of flow in which the velocity of flow at any given time changes in magnitude and direction.
5. Laminar flow : A laminar flow is one in which the fluid particles move along smooth, regular paths which can be predicted well in advance. The fluid thus, move in layers, gliding smoothly over adjacent layers.
6. Turbulent flow : A flow is said to be turbulent, when the fluid particles move in very irregular paths. This results in formation of eddies.
7. Compressible flow : A flow in which volume and density changes during the flow is called compressible flow.
8. Incompressible flow : A flow in which volume and density does not changes during the flow is called incompressible flow.
9. Rotational flow : A fluid in which the fluid particle rotate about their own axis while flowing is called rotational flow.
10. Irrotational flow : A flow in which the fluid particles do not rotate about their own axis is called irrotational flow.
11. One-Dimensional flow : A one-dimensional flow is one in which the velocity vector depends on only one space variable and time.
12. Two-Dimensional flow : A Two dimensional flow is one in which the velocity vector depends on two space variables and time.
13. Three-Dimensional flow : A three dimensional flow is one in which the velocity vector depends on three variables and time. The velocity of components can be expressed as

VII a)

DIRECT PRESSURE RELIEF VALVE

The function of pressure relief valve is to limit the pressure to a specified maximum value by diverting pump flow back to the tank. Figure illustrates the operation of a simple direct acting relief valve.

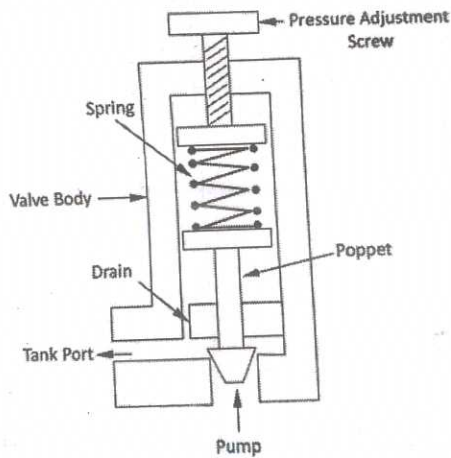

Fig-4

Exp-4

A poppet seated inside the valve will be positioned to its seat due to spring force, one adjusting screw is provided to change the setting pressure of relief valve. The primary port of a relief valve is connected to the system pressure and the secondary port is connected to the tank. The poppet is kept closed by the spring tension set on the knob until the system pressure working against the poppet reaches the cracking pressure. The poppet is forced off its seat when the system pressure reaches the poppet to the tank. Thus the required pressure in the system is maintained as per set value on the pressure relief valve.

When the pressure at inlet relief valve falls below the setting pressure, poppet will again positioned to its seat due to the action of spring force and relief valve will be closed and will not allow the flow through it.

VII B) LOBE PUMP

Figure Shows a line diagram of a lobe pump. It is similar in operation to an external gear pump. It has two rotating rotors called lobes. Here two lobes are used to rotate one against the other, creating two chambers between the lobes and the wall of the pump casing. They are driven by electric motor. Fluid that enters the static casing gets compressed between rotating lobes and the wall of the casing as it proceeds towards outlet. Volumetric capacity of fluid is more than that in gear pump. This type of pumps are used for pumping gas, air, liquid with low pressures and higher flow rate.

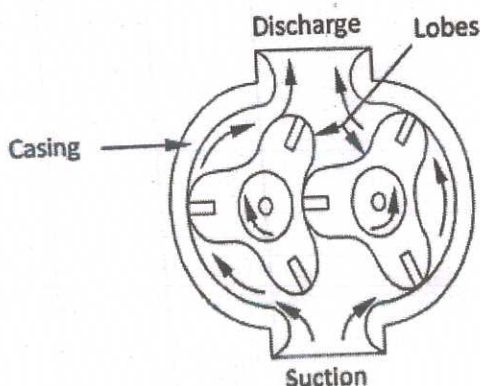

Fig-3

Exp-4

Fig-4

Exp-4

VIII a)

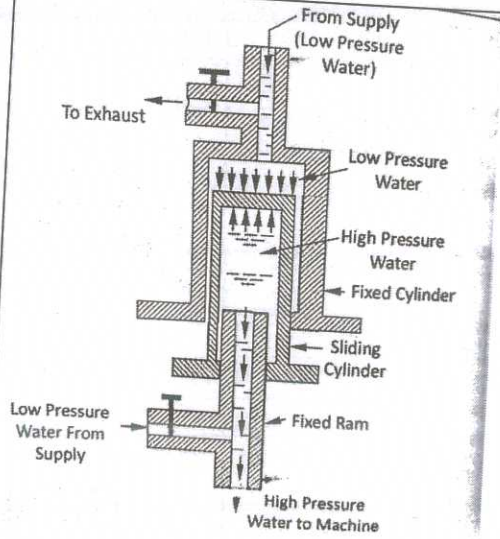

Hydraulic intensifier is a device is used to increase the intensity of pressure of liquid by means of utilizing the energy available from a large amount of liquid at a low pressure. Figure Shows the constructional features and working principle of a hydraulic intensities.

It consist of a fixed ram surrounded by a sliding cylinder which contains high pressure liquid, which is supplied to the machine through the fixed ram. The sliding cylinder is encased by a fixed cylinder which contains low pressure liquid from the main supply. The low pressure liquid from the supply enters the fixed cylinder. The weight of this water presses the sliding cylinder in the downward direction. The water in the sliding cylinder gets compressed due to downward movement of the sliding cylinder and its pressure is increased. This high pressure water is forced out of the cylinder through the fixed ram to the machine.

If P_1 = Intensity of Pressure of water form supply to the fixed cylinder.

A_1 = External area of sliding cylinder.

P_2 = intensity of pressure of water in sliding cylinder

A_2 = Area of the fixed ram

Then,

Total upward forces = Total downward forces

$$P_1 A_1 = P_2 A_2$$

$$P_2 = \frac{P_1 \times A_1}{A_2}$$

VIII
b)

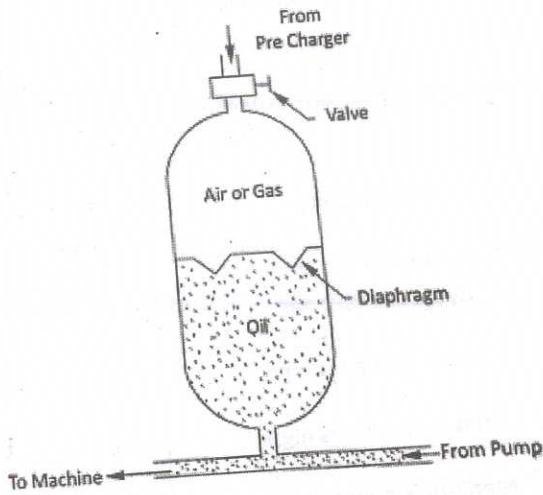

Figure Shows a diaphragm type separating accumulator. It consists of two hemispherical shells made of steel forgings. These shells are welded or locked to form a single shell.

A flexible, convoluted rubber diaphragm is clamped around the periphery of the shell. Oil is pumped into the space below the diaphragm and the space above it is charged with air or gas. Oil pressure acts on the diaphragm at its bottom and air or gas gets compressed. As the oil is drawn out by the machine connecting to the accumulator, air or gas expands and energy is released.

IX a)

The combination of filter, regulator and lubricator is called FRL unit. The FRL unit is used in all the pneumatic systems and as a service unit they come as a combined unit. In most pneumatic systems, the compressed air is first filtered and then regulated to the specific pressure and made to pass through a lubricator.

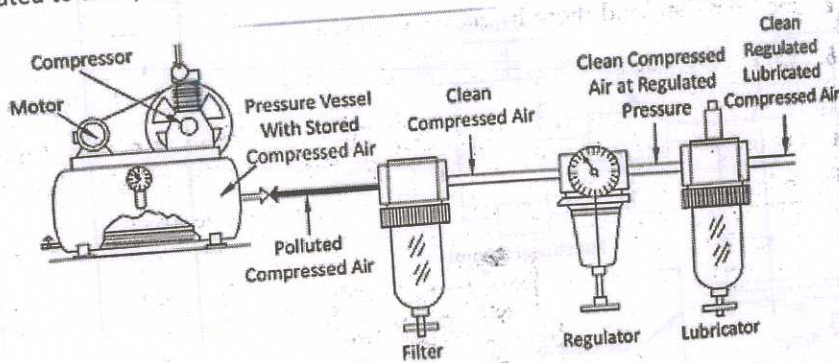

Fig-4

Exp-4

SL No	Pneumatic System	Hydraulic System
1	Pressure upto 12 bar	Pressure upto 400 bar
2	Pneumatic actuators are suitable for low or medium loads	Suitable for very high loads
3	Transmission lines are inexpensive	Transmission lines are expensive
4	Low stability	High Stability
5	Difficult to control the speed of pneumatic cylinders	Easy to control the speed of hydraulic cylinder
6	Cost of energy is low	Cost of energy is high
7	Contamination is less	Contamination is high
8	Medium is compressed air	Medium is hydraulic oil

1x7

X a) BASIC COMPONENTS OF HYDRAULIC SYSTEMS AND THEIR FUNCTIONS

Figure Shows a line diagram of a typical hydraulic system and the following are the essential components of a hydraulic system.

Fig-4
Exp-4

1. Oil reservoir
2. Filter
3. Pump
4. Control valves
5. Actuator

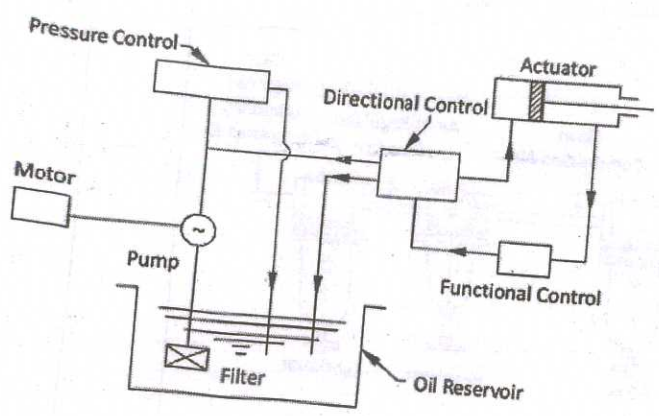

1. Oil Reservoir : It holds the sufficient oil to meet the system requirements. The hydraulic oil is taken to the actuator through piping and valves by using pump, finally oil comes back to the reservoir.
2. Filter : Filter is used to remove dirt and foreign matter collected by the oil during the flow circuits from the hydraulic fluid.

3. Pump : The function of pump on a fluid power system is to increase the pressure of fluid to enable it to flow in the circuit.
4. Control Valves : These are basically classified as :a) Pressure Control Valves, b) Direction Control Valves, c) Functional Control Valves
 - a) Pressure Control Valves : Pressure control valves regulates the pressure in the circuit. It may act as a relief valve in the circuit to divert the fluid, to protect the piping and equipment from excessive pressure.
 - b) Direction Control Valves : The function of direction control valves is to control the direction of flow of fluid in a hydraulic circuit. Some of direction control valves are check valves, two way valves etc.
 - c) Functional Control Valves : Functional Control Valves are used to adjust the flow rate of the oil and regulate the speed of the actuator.
5. Actuator: In actuator the hydraulic energy is converted into mechanical energy. The linear motion is provided by hydraulic cylinders and rotary motion by hydraulic motors.

X b) Figure shows a pneumatically operated three jaw chuck. In lathe a rotating cylinder is fixed to the head stock spindle which allows the piston rod to move inside hollow spindle. Piston rod is connected to the three jaws by means of levers. When the high pressure air is admitted to the right side of piston, the piston moves leftwards. This leftward movement of the piston actuating the lever mechanism through the piston rod. The links of the lever move the jaws towards the centre of chuck and hold the work piece firmly. For unclamping, the air is admitted to the left side of piston. The piston moves right wards. The piston rod actuates the lever mechanism and jaws moves upward. Thus releasing the work piece.

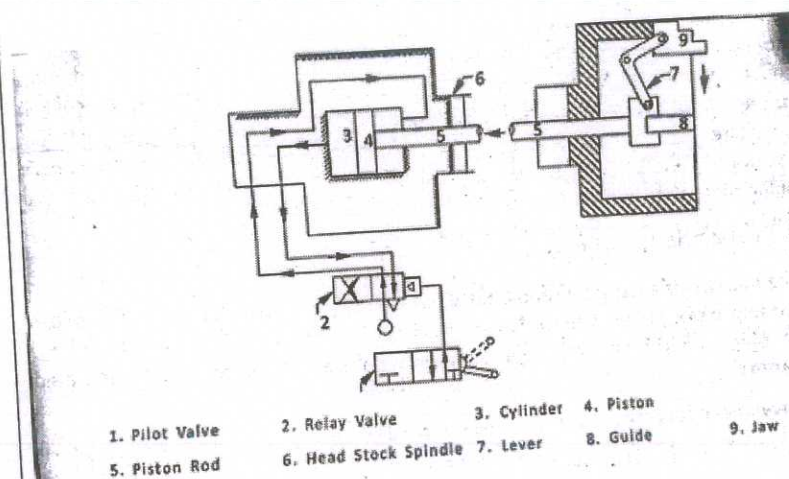

Fig-4
Exp-3