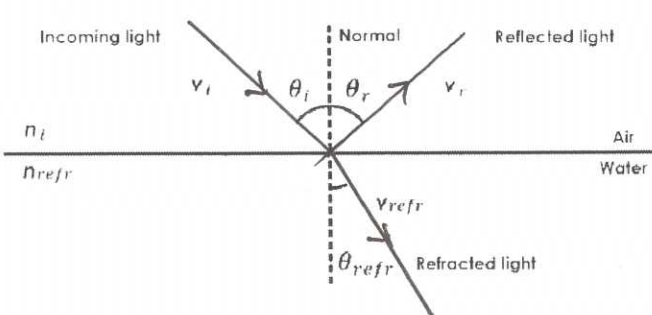

SCHEME OF EVALUATION  
(Scoring Indicators)

Revision:2015		Course Code:3041		
Course Title: Communication Engineering				
Q.NO	Scoring Indicators	Split up score	Sub Total	Total
<b>PART A</b>				
I .1.	A system of mobile nodes connected with each other via wireless medium without infrastructure support	2	2	10
2.	Electromagnetic waves are oscillations containing electric and magnetic fields travelling through free space with the speed of light	2	2	
3	A continuous time signal can be represented in its samples and can be recovered back when sampling frequency $f_s$ is greater than or equal to the twice the highest frequency component of message signal.	2	2	
4.	Automatic Frequency Control (AFC) is a method or circuit to automatically keep a resonant circuit tuned to the frequency of an incoming radio signal. It is used in radio receivers to keep the receiver tuned to the frequency of the desired station.	2	2	
5.	Limiter circuit is used in FM receiver to remove the noise present in the peaks of the received signal and to remove any amplitude variation in the received signal; the output of the limiter has constant amplitude..	2	2	
<b>PART B</b>				
II 1.		Any 3+3	6	30

SCHEME OF EVALUATION  
(Scoring Indicators)

Reflection involves a change in direction of waves when they bounce off a barrier. Refraction of waves involves a change in the direction of waves as they pass from one medium to another. Refraction, or the bending of the path of the waves, is accompanied by a change in speed and wavelength of the waves.

**Comparison between AM and FM**

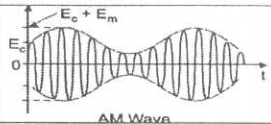
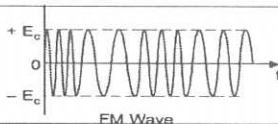
Parameter	AM	FM
1. Definition	Amplitude of carrier is varied in accordance with amplitude of modulating signal keeping frequency and phase constant.	Frequency of carrier is varied in accordance with the amplitude of modulating signal keeping amplitude and phase constant.
2. Constant parameters	Frequency and phase.	Amplitude and phase.
3. Modulated signal		
4. Modulation Index	$m = E_m/E_c$	$m = \delta/f_m$
5. Number of sidebands	Only two	Infinite and depends on $m_f$ .
6. Bandwidth	$BW = 2f_m$	$BW = 2(\delta + f_{m(max)})$
7. Application	MW, SW band broadcasting, video transmission in TV.	Broadcasting FM, audio transmission in TV.

Any 6

**1. Reduction in the height of antenna**

For the transmission of radio signals, the antenna height must be multiple of  $\lambda/4$ , where  $\lambda$  is the wavelength.

$$\lambda = c/f$$

The minimum antenna height required to transmit a baseband signal of  $f = 10$  kHz is calculated as follows :

$$\text{Minimum antenna height} = \frac{\lambda}{4} = \frac{c}{4f} = \frac{3 \times 10^8}{4 \times 10 \times 10^3} = 7500 \text{ meters i.e. } 7.5 \text{ km}$$

The antenna of this height is practically impossible to install.

consider a modulated signal at  $f = 1$  MHz. The minimum antenna height is given by,

$$\text{Minimum antenna height} = \frac{\lambda}{4} = \frac{c}{4f} = \frac{3 \times 10^8}{4 \times 10 \times 10^6} = 75 \text{ meters}$$

Thus, modulation reduces the height of the antenna.

**2. Avoids mixing of signals**

If the baseband sound signals are transmitted without using the modulation by more than one transmitter, then all the signals will be in the same frequency range i.e. 0 to 20 kHz. Therefore, all the signals get mixed

Any 4

1.5x 4

6

together and a receiver cannot separate them from each other .Hence, if each baseband sound signal is used to modulate a different carrier then they will occupy different slots in the frequency domain (different channels). Thus, modulation avoids mixing of signals.

**3. Increase the Range of Communication**

The modulation process increases the frequency of the signal to be transmitted. Therefore, it increases the range of communication.

**4. Multiplexing is possible**

This is possible only with modulation. The multiplexing allows the same channel to be used by many signals. Hence, many TV channels can use the same frequency range, without getting mixed with each other or different frequency signals can be transmitted at the same time .

**5. Improves Quality of Reception**

With frequency modulation (FM) and the digital communication techniques such as PCM, the effect of noise is reduced to a great extent. This improves quality of reception.

4 **Pre-emphasis:** The noise suppression ability of FM decreases with the increase in the frequencies. Thus increasing the relative strength or amplitude of the high frequency components of the message signal before modulation is termed as Pre-emphasis.

**De-emphasis:** In the de-emphasis circuit, by reducing the amplitude level of the received high frequency signal by the same amount as the increase in pre-emphasis is termed as De-emphasis.

- The pre-emphasis process is done at the transmitter side, while the de-emphasis process is done at the receiver side.
- Thus a high frequency modulating signal is emphasized or boosted in amplitude in transmitter before modulation. To compensate for this boost, the high frequencies are attenuated or de-emphasized in the receiver after the demodulation has been performed.
- Pre-emphasis circuit is a high pass filter or differentiator which allows high frequencies to pass, whereas de-emphasis circuit is a low pass filter or integrator which allows only low frequencies to pass.

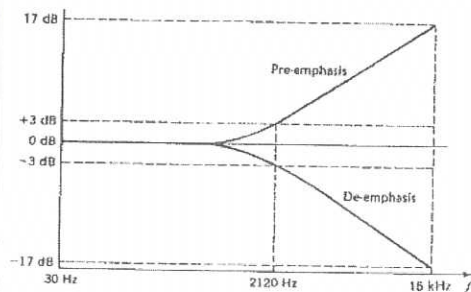

6  
Fig 2  
+exp  
4

SCHEME OF EVALUATION  
(Scoring Indicators)

- 5
- When the characteristics of the noise are known and are different from signals, it is possible to filter it or process the signal
  - Internal noise of the electronic system can be reduced by low noise amplifiers.
  - Noise can be reduced by controlling the environment.

3x2

6

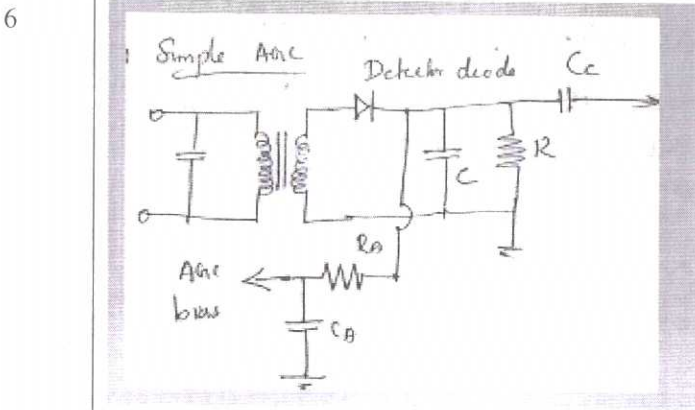

Fig 3+  
exp 3

6

In simple AGC the AM diode detector produces the DC level that is proportional to the message signal. This DC level is fed to an RC LPF to remove the audio signal which forms the AGC bias correction voltage. This AGC bias is then applied to the base of IF and RF amplifier transistors to control their gain. When the incoming signal level increases, AGC bias voltage increases which in turn reduces the IF and RF amplifier gains.

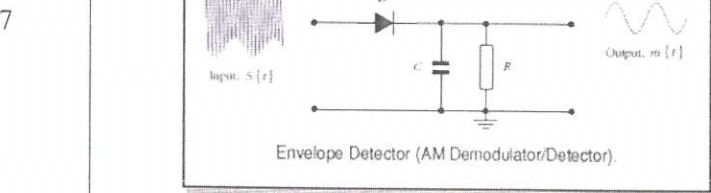

Fig3  
+  
exp 3

6

In rectifying the RF signal, the AM diode detector provides an output equivalent to the envelope of one half of the signal, i.e. it is an envelope detector. The incoming amplitude modulated RF signal consists of a waveform of both positive and negative going voltages. The diode envelope detector rectifies the waveform leaving only the positive or negative half of the waveform. The high frequency element of this is then filtered out, typically using a capacitor which forms the low pass filter.

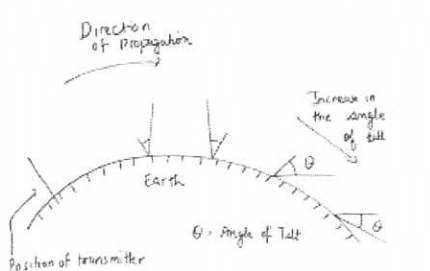

SCHEME OF EVALUATION  
Scoring Indicators)

<p>IV b</p>	<p>for the application of Parabolic reflector antennas is above 1MHz. These antennas are widely used for radio and wireless applications.</p> <ul style="list-style-type: none"> <li>The standard definition of a parabola is - Locus of a point, which moves in such a way that its distance from the fixed point (called focus) plus its distance from a straight line (called directrix) is constant. The point F is the focus (feed is given) and V is the vertex. The line joining F and V is the axis of symmetry. PQ are the reflected rays where L represents the line directrix on which the reflected points lie. All the waves originating from focus, reflects back to the parabolic axis. Hence, all the waves reaching the aperture are in phase.</li> <li>As the waves are in phase, the beam of radiation along the parabolic axis will be strong and concentrated.</li> </ul> <p>Ground Wave propagation is a method of radio wave propagation that uses the area between the surface of the earth and the ionosphere for transmission. The ground wave can propagate a considerable distance over the earth's surface particularly in the low frequency and medium frequency portion of the radio spectrum.</p> <p>Ground wave radio signal propagation is ideal for relatively short distance propagation on these frequencies during the daytime. A <i>ground wave</i> radio signal is made up of a number of constituent waves. If the antennas are in the line of sight then there will be a direct wave as well as a reflected signal. The direct signal is one that travels directly between the two antennas and is not affected by the locality. There will also be a reflected signal as the transmission will be reflected by a number of objects including the earth's surface and any hills, or large buildings that may be present. In addition to this there is a surface wave. This tends to follow the curvature of the Earth and enables coverage beyond the horizon. It is the sum of all these components that is known as the ground wave. Beyond the horizon the direct and reflected waves are blocked by the curvature of the Earth, and the signal is purely made up of the diffracted surface wave. It is for this reason that surface wave is commonly called ground wave propagation.</p> 	<p>Fig4 +exp 4</p> <p>Fig4 + Exp3</p>	<p>8</p> <p>7</p>	
-------------	--	---	-------------------	--

SCHEME OF EVALUATION  
Scoring Indicators)

V.a

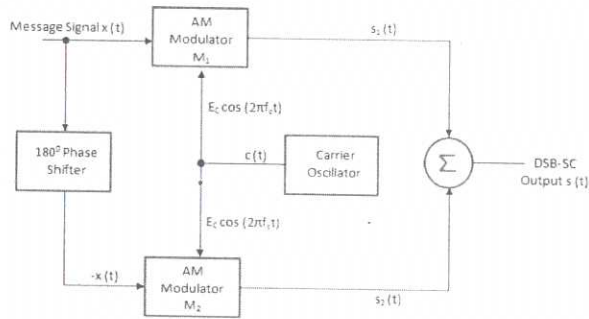

It consists of two standard amplitude modulators arranged in the balanced configuration so as to suppress the carrier completely. The carrier signal  $c(t)$  is connected to both AM modulators  $M_1$  and  $M_2$ . The message signal  $x(t)$  is applied as it is to  $M_1$  and its inverted version  $-x(t)$  is applied to  $M_2$ .

output of  $M_1$  :  $s_1(t) = E_c[1 + m x(t)] \cos(2\pi f_c t)$

output of  $M_2$  :  $s_2(t) = E_c[1 - m x(t)] \cos(2\pi f_c t)$

These are then applied to a subtractor and the subtractor produces the desired DSB-SC signal

Subtractor output =  $s_1(t) - s_2(t)$

$$\begin{aligned} &= E_c[1 + m x(t)] \cos(2\pi f_c t) - E_c[1 - m x(t)] \cos(2\pi f_c t) \\ &= E_c \cos(2\pi f_c t) [\{1 + m x(t)\} - \{1 - m x(t)\}] \\ &= E_c \cos(2\pi f_c t) [1 + m x(t) - 1 + m x(t)] \\ &= 2m E_c x(t) \cos(2\pi f_c t) \end{aligned}$$

The R.H.S. of this expression consists of product of  $x(t)$  and  $c(t) = E_c \cos(2\pi f_c t)$ .

Hence, it represents a DSB-SC signal.

Fig 4+Ex p4

8

V.b

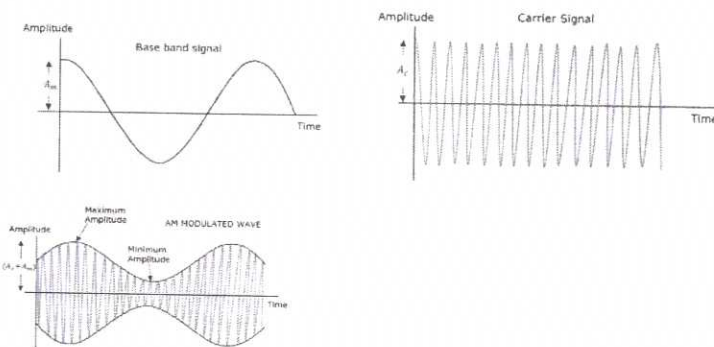

Let the modulating signal be,

$$m(t) = A_m \cos(2\pi f_m t)$$

and the carrier signal be,

$$c(t) = A_c \cos(2\pi f_c t)$$

SCHEME OF EVALUATION  
Scoring Indicators)

$A_m$  and  $A_c$  are the amplitude of the modulating signal and the carrier signal respectively.  
 $f_m$  and  $f_c$  are the frequency of the modulating signal and the carrier signal respectively.

Then, the equation of Amplitude Modulated wave will be

$$s(t) = [A_c + A_m \cos(2\pi f_m t)] \cos(2\pi f_c t)$$

$$s(t) = [A_c + A_m \cos(2\pi f_m t)] \cos(2\pi f_c t) \dots\dots\dots \text{EQN1}$$

Modulation Index or Modulation Depth states the level of modulation that a carrier wave undergoes.

Rearrange the Equation 1

$$s(t) = A_c [1 + (A_m/A_c) \cos(2\pi f_m t)] \cos(2\pi f_c t)$$

$$s(t) = A_c [1 + (A_m/A_c) \cos(2\pi f_m t)] \cos(2\pi f_c t)$$

$$\Rightarrow s(t) = A_c [1 + \mu \cos(2\pi f_m t)] \cos(2\pi f_c t) \Rightarrow$$

$$s(t) = A_c [1 + \mu \cos(2\pi f_m t)] \cos(2\pi f_c t) \dots\dots\dots \text{EQN2}$$

Where,  $\mu$  is Modulation index and it is equal to the ratio of  $A_m$  and  $A_c$ .  
 $\mu = A_m/A_c$

VI.a **Pulse Amplitude Modulation (PAM)** is an analog modulating scheme in which the amplitude of the pulse carrier varies proportional to the instantaneous amplitude of the message signal.

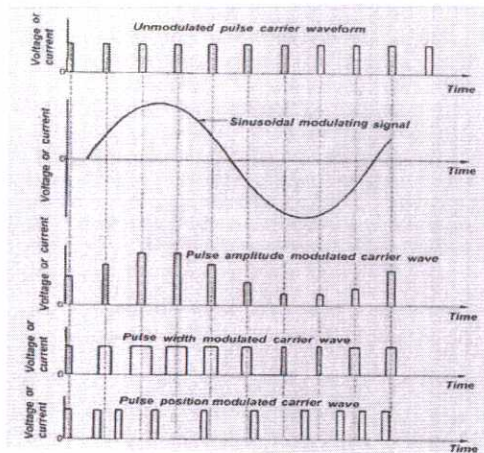

**Pulse Width Modulation (PWM)** or **Pulse Duration Modulation (PDM)** or **Pulse Time Modulation (PTM)** is an analog modulating scheme in which the duration or width or time of the pulse carrier varies proportional to the instantaneous amplitude of the message signal.

**Pulse Position Modulation (PPM)** is an analog modulating scheme in

7  
7

Fig 3+  
exp6 9

SCHEME OF EVALUATION  
(Scoring Indicators)

which the amplitude and width of the pulses are kept constant, while the position of each pulse, with reference to the position of a reference pulse varies according to the instantaneous sampled value of the message signal.

VI.b

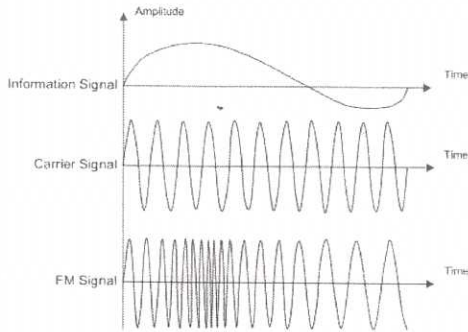

Carson's Rule can be expressed simply as a formula:

$$BT = 2(\Delta f + f_m)$$

**Where:**

$\Delta f$  = deviation

BT = total bandwidth

$f_m$  = modulating frequency

3+3

6

VII. a

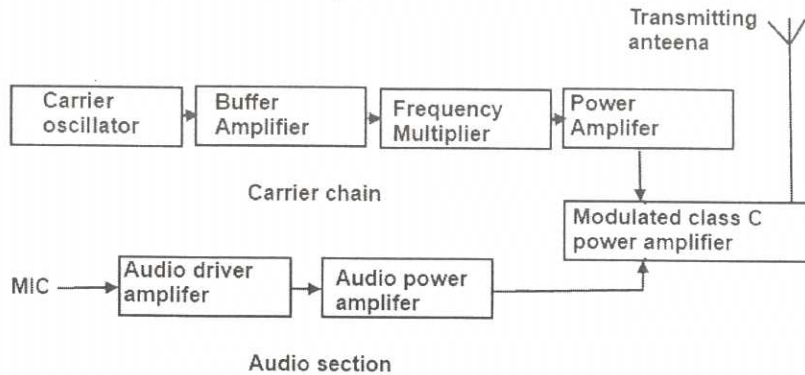

Figure (a) Block diagram of high level AM transmitter

In high-level transmission, the powers of the carrier and modulating signals are amplified before applying them to the modulator stage.

**Carrier oscillator**

The carrier oscillator generates the carrier signal, which lies in the RF range. The frequency of the carrier is always very high

**Buffer Amplifier**

The purpose of the buffer amplifier is two fold. It first matches the output impedance of the carrier oscillator with the input impedance of the frequency multiplier, the next stage of the carrier oscillator. It then isolates the carrier oscillator and frequency multiplier.

Fig  
4+  
exp 4

8

**Frequency Multiplier**

The sub-multiple frequency of the carrier signal, generated by the carrier oscillator, is now applied to the frequency multiplier through the buffer amplifier. This stage is also known as harmonic generator. The frequency multiplier generates higher harmonics of carrier oscillator frequency.

**Power Amplifier**

The power of the carrier signal is then amplified in the power amplifier stage.

**Audio Chain**

The audio signal to be transmitted is obtained from the microphone. The audio driver amplifier amplifies the voltage of this signal. This amplification is necessary to drive the audio power amplifier.

**Modulated Class C Amplifier**

This is the output stage of the transmitter. The modulating audio signal and the carrier signal, after power amplification, are applied to this modulating stage. The modulation takes place at this stage. The class C amplifier also amplifies the power of the AM signal to the required transmitting power. This signal is finally passed to the antenna, which radiates the signal into space of transmission.

VII.b.

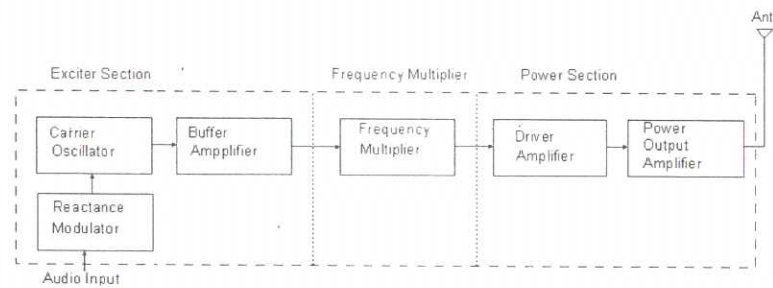

**The Exciter**

- The function of the *carrier oscillator* is to generate a stable sine wave signal at the rest frequency, when no modulation is applied. It must be able to linearly change frequency when fully modulated, with no measurable change in amplitude.
- The buffer amplifier acts as a constant high-impedance load on the oscillator to help stabilize the oscillator frequency.
- The modulator acts to change the carrier oscillator frequency by application of the message signal.

**Frequency Multiplier**

- Frequency multipliers are tuned-input, tuned-output RF amplifiers in which the output resonant circuit is tuned to a multiple of the input frequency.

**Power output section**

- The final power section develops the carrier power, to be transmitted and often has a low-power amplifier driven the final power amplifier.

Fig  
4+  
exp3

7

SCHEME OF EVALUATION  
Scoring Indicators)

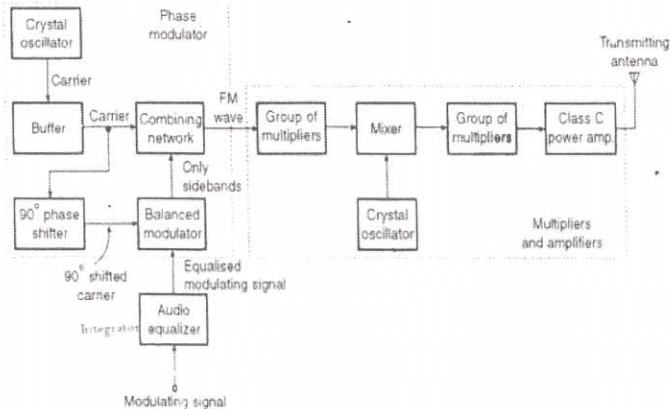
VIII. a	 <ul style="list-style-type: none"> <li>• The crystal oscillator generates the carrier at low frequency typically at 1MHz. This is applied to the combining network and a 90° phase shifter.</li> <li>• The modulating signal is passed through an audio equalizer to boost the low modulating frequencies. The modulating signal is then applied to a balanced modulator.</li> <li>• The balanced modulator produced two side bands such that their resultant is 90° phase shifted with respect to the unmodulated carrier.</li> <li>• The unmodulated carrier and 90° phase shifted sidebands are added in the combining network.</li> <li>• At the output of the combining network we get Fm wave. This wave has a low carrier frequency <math>f_c</math> and low value of the modulation index <math>m_f</math>.</li> <li>• The carrier frequency and the modulation index are then raised by passing the FM wave through the first group of multipliers. The carrier frequency is then raised by using a mixer and then the <math>f_c</math> and <math>m_f</math> both are raised to required high values using the second group of multipliers.</li> <li>• The FM signal with high <math>f_c</math> and high <math>m_f</math> is then passed through a class C power amplifier to raise the power level of the FM signal.</li> </ul>	Fig 5+ exp 4	9
VIII.b.	<p><b>Internal noise:</b></p> <ol style="list-style-type: none"> <li>1. Shot noise</li> <li>2. Partition noise</li> <li>3. Low frequency/flicker noise</li> <li>4. High frequency/transit time noise</li> <li>5. Thermal noise</li> </ol>	Any 6	6

IX.a.	<p><b>External noise</b></p> <ol style="list-style-type: none"> <li>1. Atmospheric noise</li> <li>2. Extra terrestrial noise</li> <li>3. Industrial noise</li> </ol> <div style="text-align: center; margin: 10px 0;"> </div> <ul style="list-style-type: none"> <li>• In the superheterodyne receiver, the incoming signal through the antenna is filtered to reject the image frequency and then amplified by the RF amplifier.</li> <li>• RF amplifier can be tuned to select and amplify a particular carrier frequency within the AM broadcast range.</li> <li>• The amplified RF frequency is then mixed with the local oscillator frequency.</li> <li>• The combining of these two signals is done at the mixer which produces sum and difference frequency signals of the incoming carrier signal and local oscillator signal, which are <math>f_{OSC}+f_{RF}</math> and <math>f_{OSC}-</math></li> <li>• The sum frequency is rejected by the filter and the remaining difference frequency signal which is a down converted frequency signal is called as intermediate frequency (IF) carrier</li> <li>• The modulation of the IF carrier signal is same as that of the original carrier signal and it has a fixed frequency of 455kHz which is amplified by one or more stages of amplification.</li> <li>• This amplified IF signal is applied to the detector to detect the information signal component from 455 kHz IF, to reproduce the original information data, which is generally in the form of audio signal.</li> <li>• The RF component is filtered out and audio is supplied to the audio stages for amplification.</li> <li>• The generated audio signal is then applied to the AF amplifier to increase the audio frequency level of the signal and to provide</li> </ul>			
-------	---	--	--	--

Fig4  
+  
exp 5 9

SCHEME OF EVALUATION  
(Scoring Indicators)

<p>IX.b.</p>	<p>enough gain to drive the speaker or headphones.</p> <ul style="list-style-type: none"> <li>A speaker is connected to the AF amplifier to play the audio information signal.</li> </ul> <ol style="list-style-type: none"> <li>If IF is too high poor selectivity and poor adjacent channel rejection occurs</li> <li>A high value of IF increases tracking difficulties</li> <li>If IF is too low poor image frequency rejection occurs</li> <li>If IF too low frequency stability of local oscillator must be made correspondingly high.</li> <li>Low value of IF results in rejection of wanted sidebands.</li> </ol>	<p>Any 4 x1.5</p>	<p>6</p>	
<p>X.a.</p>	<p><b>Sensitivity:</b> It is the ability to amplify weak signal. It is defined in terms of voltage which must be applied at the receiver input terminals to provide a std output power.</p> <p><b>Selectivity:</b> It may be defined as ability to reject unwanted signals.</p> <p><b>Fidelity:</b> It is the ability of the amplifier to reproduce all the modulating frequencies equally .</p> <p><b>Noise Figure:</b> It is defined as the ratio of signal to noise power ratio supplied to the input terminals of a receiver to the signal to noise power ratio at the output</p>	<p>4x2</p>	<p>8</p>	
<p>X.b.</p>	<div style="text-align: center;"> </div> <ul style="list-style-type: none"> <li>➤ In the superheterodyne receiver, the incoming signal through the antenna is filtered to reject the image frequency and then amplified by the RF amplifier.</li> <li>➤ RF amplifier can be tuned to select and amplify a particular carrier frequency within the AM broadcast range.</li> <li>➤ The amplified RF frequency is then mixed with the local oscillator frequency.</li> <li>➤ The combining of these two signals is done at the mixer which</li> </ul>			

SCHEME OF EVALUATION  
(Scoring Indicators)

	<p>produces sum and difference frequency signals of the</p> <ul style="list-style-type: none"> <li>➤ incoming carrier signal and local oscillator signal,</li> <li>➤ The sum frequency is rejected by the filter and the remaining difference frequency signal which is a down converted frequency signal is called as intermediate frequency (IF) carrier</li> <li>➤ The modulation of the IF carrier signal is same as that of the original carrier signal .</li> <li>➤ This amplified IF signal is applied to the discriminator to detect the information signal component.</li> <li>➤ The RF component is filtered out and audio is supplied to the audio stages for amplification..</li> <li>➤ A speaker is connected to the AF amplifier to play the audio information signal.</li> <li>➤ Limiter circuit is used in FM receiver to remove the noise present in the peaks of the received signal and to remove any amplitude variation in the received signal; the output of the limiter has constant amplitude.</li> </ul>	<p>Fig3 + exp 4</p>	<p>7</p>	
--	---	-----------------------------	----------	--