



## PART — C

(Maximum marks : 60)

(Answer *one* full question from each unit. Each full question carries 15 marks.)

## UNIT — I

- III (a) State the relation between bulk modulus and modulus of rigidity. 5
- (b) A steel bar 300mm long 50mm wide and 40mm thick is subjected to a pull of 300KN in the direction of its length. Determine the change in volume. Take  $E = 2 \times 10^5 \text{ N/mm}^2$  and  $\mu = 0.25$ . 10

OR

- IV (a) Explain the shear stress and shear strain. 5
- (b) Two parallel walls 6m apart are stayed together by a steel rod 25 mm diameter passing through metal plates and nuts at each end. The nut are tightened, when the rod is at a temperature of  $100^\circ \text{C}$ . Determine the stress in the rod, when the temperature falls to  $60^\circ \text{C}$ , if
- (i) the ends do not yield
- (ii) the ends yield by 1mm. Take  $E = 200 \text{ GPa}$  and  $\alpha = 12 \times 10^{-6}/^\circ \text{C}$ . 10

## UNIT — II

- V (a) State parallel axis theorem. 5
- (b) Find the moment of inertia of a hollow section as shown figure about an axis passing through its c.g and parallel to XX axis. All dimensions are in mm.

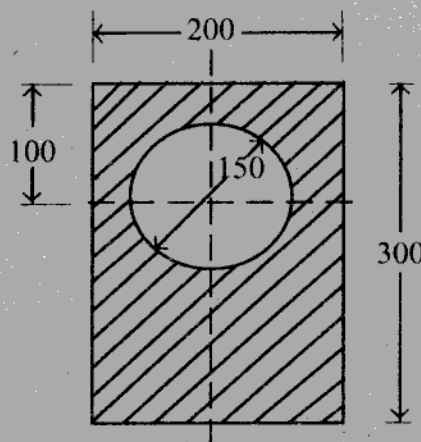

10

OR

- VI (a) Define moment of inertia and radius gyration. 5
- (b) A semicircle of 90mm radius out from a trapezium as shown in figure. Find the centre of gravity of the figure. All dimensions are in mm.

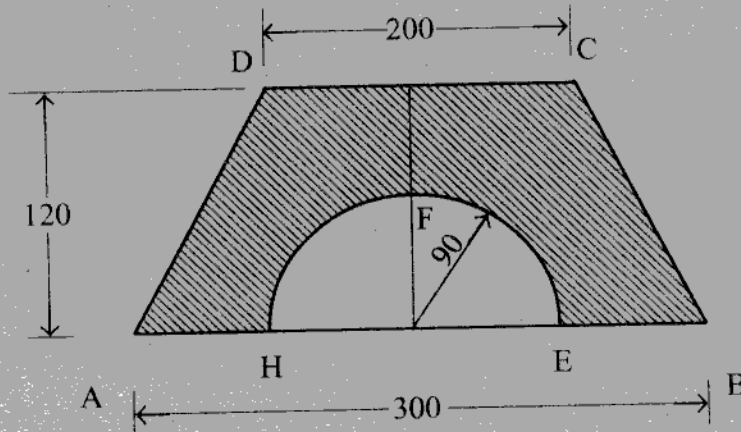

10

## UNIT — III

- VII (a) List the different types of welded joints. 5
- (b) A solid shaft has to transmit 75 KW at 200rpm. Taking allowable shear stress as  $70 \text{ N/mm}^2$ . Find suitable diameter for the shaft, if the maximum torque transmitted at each revolution exceeds the mean by 30%. 10

OR

- VIII (a) State the assumptions of torsion equation. 5
- (b) A cylindrical shell of 1.3m diameter is made up of 18 mm thick plates. Find the circumferential and longitudinal stress in the plates, if the boiler is subjected to an internal pressure of 2.4 MPa. Take efficiency of the joint as 70%. 10

## UNIT — IV

- IX (a) What are the assumptions made in the Euler's column theory. 5
- (b) A cantilever of length 2m carries a uniformly distributed load of 2KN/m length over the whole length and a point load of 3KN at the free end. Draw the shear force and bending moment diagram for the cantilever. 10

OR

- X (a) Differentiate slenderness ratio and equivalent length. 5
- (b) A cantilever 120mm wide and 200mm deep is 2.5m long. What is the uniformly distributed load which the beam can carry in order to produce a deflection of 5mm at the free end? Take  $E = 200 \text{ GN/m}^2$ . 10