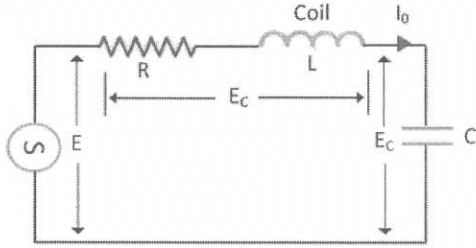
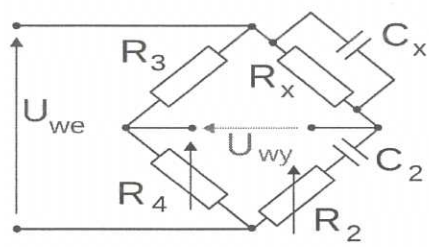
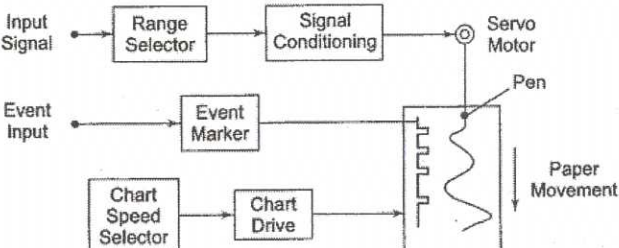
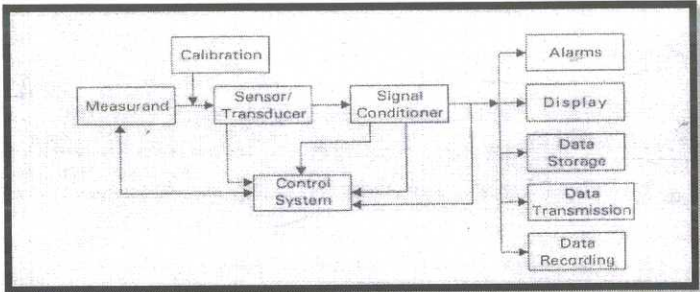
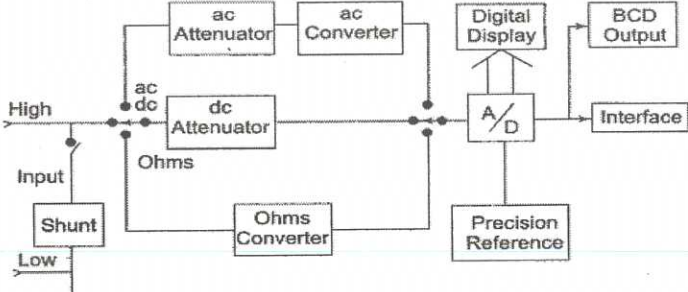

SCHEME OF VALUATION
(Scoring Indicators)

Revision: 2010				
Course Code: 4041				
Course Title: Electronics Instruments and Measurements				
Qst. No	Scoring Indicator	Split Up Score	Sub Total	Total
<u>PART A</u>				
I(i)	Resolution (MSA) is the ability of the measurement system to detect and faithfully indicate small changes in the characteristic of the measurement result.	2		
I(ii)	It is composed of several thermocouples connected usually in series or, less commonly, in parallel.	2		
I(iii)	i) To test an electrical or electronic circuit. ii) To generate periodic signals.	2		
I(iv)	Telemetry is the automatic measurement and wireless transmission of data from remote sources.	2		
I(v)	<ul style="list-style-type: none"> • Accuracy • Input impedance 	2		
				10
<u>PART B</u>				
II(i)	Galvanometer works on the principle of conversion of electrical energy into mechanical energy. When a current flows in a magnetic field it experiences a magnetic torque. If it is free to rotate under a controlling torque, it rotates through an angle proportional to the current flowing through it.	3	6	

		3	6	
<p>II(ii)</p>	<p>The working of CRT depends on the movement of electrons beams. The electron guns generate sharply focused electrons which are accelerated at high voltage. This high-velocity electron beam when strikes on the fluorescent screen creates luminous spot</p>	3	6	
<p>II(iii)</p>	<p> Primary transducer Secondary transducer Analog transducer Digital transducer Electrical transducer Mechanical transducer Active transducer Passive transducer </p>	6	6	
<p>II(iv)</p>	<p>The Q meter works on series resonant. The resonance is the condition exists in the circuit when their inductance and <u>capacitance</u> reactance are of equal magnitude. They induce energy which is oscillating between the electric and magnetic field of the capacitor and inductor respectively.</p>	3	6	

	 <p> $X_C = X_L$ $E_C = I_{XC} = I_{XL}$ $E = I_R$ $Q = X_L/R = X_C/R = E_C/E$ </p>	3		
<p>II(v)</p>	<p>The Wien's bridge use in AC circuits for determining the value of unknown frequency. The bridge measures the frequencies from 100Hz to 100kHz. The bridge is used for various other applications like <u>capacitance</u> measurement, harmonic distortion analyser and in the HF frequency oscillator.</p>  $f = \frac{1}{2\pi \sqrt{C_1 R_1 C_3 R_3}}$	3	6	
<p>II(vi)</p>	<p>Strip chart recorders consist of a roll or strip of paper that passes linearly beneath one or more pens. As the signal changes, each pen's deflection records the process being measured in the form of a chart</p> 	3	6	

<p>II(vii)</p>	<p>This instrumentation system consists of a type of transducer as the input stage, depending upon the physical quantity to be measured. The transducers output is fed to the pre-amplifier. The instrumentation amplifier is the intermediate stage. The output of the instrumentation amplifier can be connected to various devices, such as meter, oscilloscope, charts or magnetic recorders.</p> 	<p>3 3</p>	<p>6</p>	<p>30</p>														
<p>III(a)</p>	<p>In a typical Digital multimeter the input signal i.e ac or dc voltage, current, resistance, temperature or any other parameter is converted to dc voltage within the range of the ADC. The analog to digital converter then converts the pre-scaled dc voltage into its equivalent digital numbers which will be displayed on the display unit.</p> 	<p>4 5</p>	<p>9</p>															
<p>III(b)</p>	<table border="1" data-bbox="341 1458 1082 1906"> <thead> <tr> <th>M.C Instruments</th> <th>M.I Instruments</th> </tr> </thead> <tbody> <tr> <td>1. MC type instruments are more accurate.</td> <td>1. MI type are less accurate than MC type.</td> </tr> <tr> <td>2. Manufacturing cost is high.</td> <td>2. Cheap in cost.</td> </tr> <tr> <td>3. Reading scale is uniformly distributed.</td> <td>3. Non-uniform scale (scale cramped at beginning and finishing)</td> </tr> <tr> <td>4. Very sensitive in construction & for input.</td> <td>4. Robust in construction.</td> </tr> <tr> <td>5. Low power consumption</td> <td>5. Slightly high power consumption.</td> </tr> <tr> <td>6. Eddy current damping is used.</td> <td>6. Air friction damping is used.</td> </tr> </tbody> </table>	M.C Instruments	M.I Instruments	1. MC type instruments are more accurate.	1. MI type are less accurate than MC type.	2. Manufacturing cost is high.	2. Cheap in cost.	3. Reading scale is uniformly distributed.	3. Non-uniform scale (scale cramped at beginning and finishing)	4. Very sensitive in construction & for input.	4. Robust in construction.	5. Low power consumption	5. Slightly high power consumption.	6. Eddy current damping is used.	6. Air friction damping is used.	<p>6</p>	<p>6</p>	
M.C Instruments	M.I Instruments																	
1. MC type instruments are more accurate.	1. MI type are less accurate than MC type.																	
2. Manufacturing cost is high.	2. Cheap in cost.																	
3. Reading scale is uniformly distributed.	3. Non-uniform scale (scale cramped at beginning and finishing)																	
4. Very sensitive in construction & for input.	4. Robust in construction.																	
5. Low power consumption	5. Slightly high power consumption.																	
6. Eddy current damping is used.	6. Air friction damping is used.																	

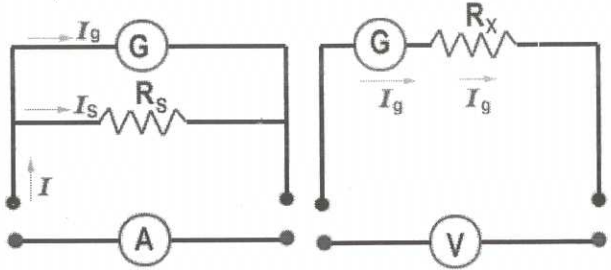
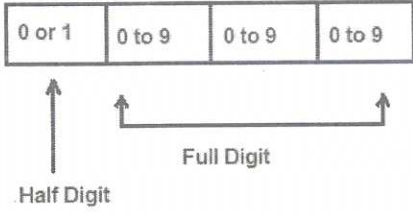
<p>IV(a)</p>	<p>An ammeter is an instrument used to measure the current passing through a circuit. A galvanometer can be converted into ammeter by connecting a low resistance called shunt in parallel to the galvanometer. A voltmeter is a device used to measure the potential difference between two points in a circuit.</p> 	<p>4</p>	<p>8</p>	
<p>IV(b)</p>	<p>3.5 digit displays have four digits: one half digit and three full digits. As half digit is the most significant digit and can either have vale 0 or 1 and full digit can take any value (0 to 9), therefore the range of digital display will be 0 to 1999</p>  <p>4.5 digit display have five digits: 1 half digit and 4 full digit. Thus as discussed in 3.5 digit display, the range of the display will be 0 to 19999. As negative sign can also be displayed by the instrument, the range will be -19999 to 19999.</p>	<p>31/2</p>	<p>7</p>	
<p>V(a)</p>	<p>The CRO stands for a cathode ray oscilloscope. It is typically divided into four sections which are display, vertical controllers, horizontal controllers, and Triggers. We can analyze the waveform by plotting amplitude along with the x-axis and y-axis. The applications of CRO's mainly involve in the radio, TV receivers, also in laboratory work involving research and design. In modern electronics, the CRO plays an important role in the electronic circuits</p>	<p>4</p>		

	<p>Block Diagram of Cathode Ray Oscilloscope (CRO)</p>	4	8
V(b)	<p>The capacitive transducer works on the principle of variable capacitances. The capacitance of the capacitive transducer changes because of many reasons like overlapping of plates, change in distance between the plates and dielectric constant. The capacitive transducer contains two parallel metal plates.</p> <p style="text-align: center;">Capacitive Transducer</p> <p style="text-align: center;">www.InstrumentationToday.com</p>	4	7
VI(a)	<p>The digital storage oscilloscope is defined as the oscilloscope which stores and analysis the signal digitally, i.e. in the form of 1 or 0 preferably storing them as analogue signals. The digital oscilloscope digitises and stores the input signal. This can be done by the use of CRT and digital memory.</p> <p style="text-align: center;">Figure - Block Diagram of DSO</p>	4	8

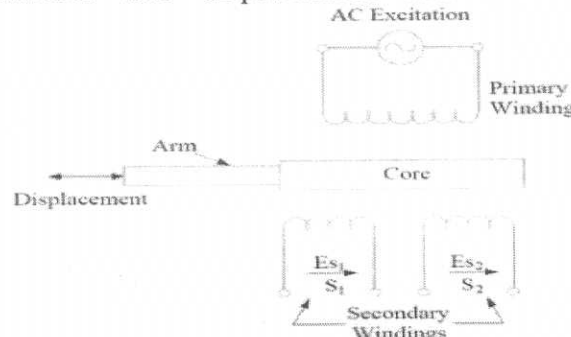
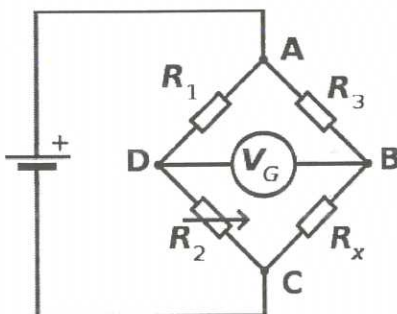
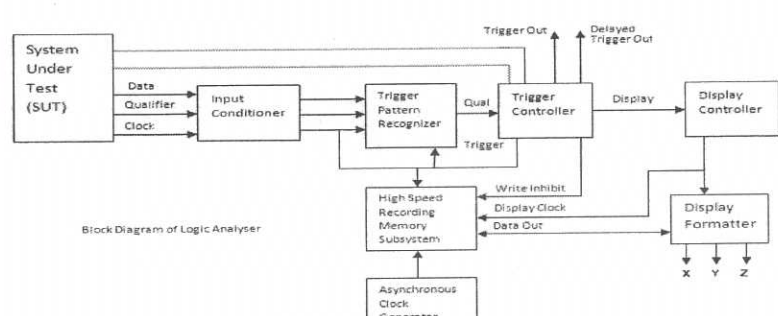
<p>VI(b)</p>	<p>Linear variable differential transformers (LVDT) are used to measure displacement. When the displacement to be measured is applied to the arm of the core, the LVDT converts this displacement into an electrical signal</p> 	<p>4</p>	<p>7</p>	
<p>VII(a)</p>	 <p style="text-align: right;">$R_x = R_2 R_3 / R_1$</p> <p>A Wheatstone bridge is an electrical circuit used to measure an unknown electrical resistance by balancing two legs of a bridge circuit, one leg of which includes the unknown component.</p>	<p>3</p>	<p>7</p>	<p>4</p>
<p>VII(b)</p>	<p>The most popular test instrument for trouble shooting digital and microprocessor based systems is the logic analyzer. Its appearance is similar to CRO but it looks into the activity on the communicating links in a digital system known as interface buses.</p>  <p style="text-align: center;">Block Diagram of Logic Analyser</p>	<p>4</p>	<p>8</p>	<p>4</p>

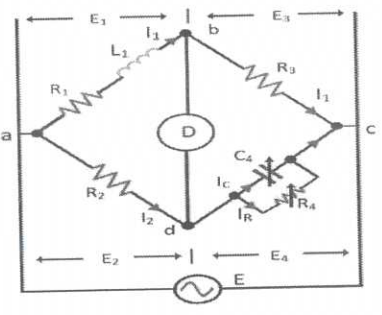
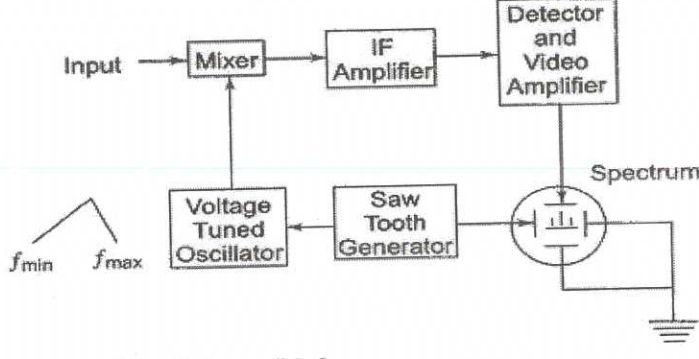
<p>VIII(a)</p>	 $R_1 = \frac{R_2 R_3}{R_4}$ $L_1 = R_2 R_3 C_4$ <p>The bridge used for the measurement of self-inductance of the circuit is known as the Maxwell bridge. It is the advanced form of the <u>Wheatstone bridge</u>. The Maxwell bridge works on the principle of the comparison, i.e., the value of unknown inductance is determined by comparing it with the known value or standard value.</p>	<p>3</p> <p>7</p> <p>4</p>	
<p>VIII(b)</p>	<p>The most common way of observing signals is to display them on an oscilloscope, with time as the X-axis . This is the time domain. It is also useful to display signals in the frequency domain. The instrument providing this frequency domain view is the spectrum analyzer.</p> 	<p>4</p> <p>8</p> <p>4</p>	
<p>IX(a)</p>	<p>An XY recorder plots the instantaneous relation between two variables . The output of the error detector is given to a chopper. The servo amplifier driven by the chopper. The amplifiers output drives the pen. The Y amplifiers output drives the arm. Square shaped graph paper will be used. It is fixed over a pad by electrostatic attraction or by vacuum.</p>	<p>4</p>	<p>9</p>

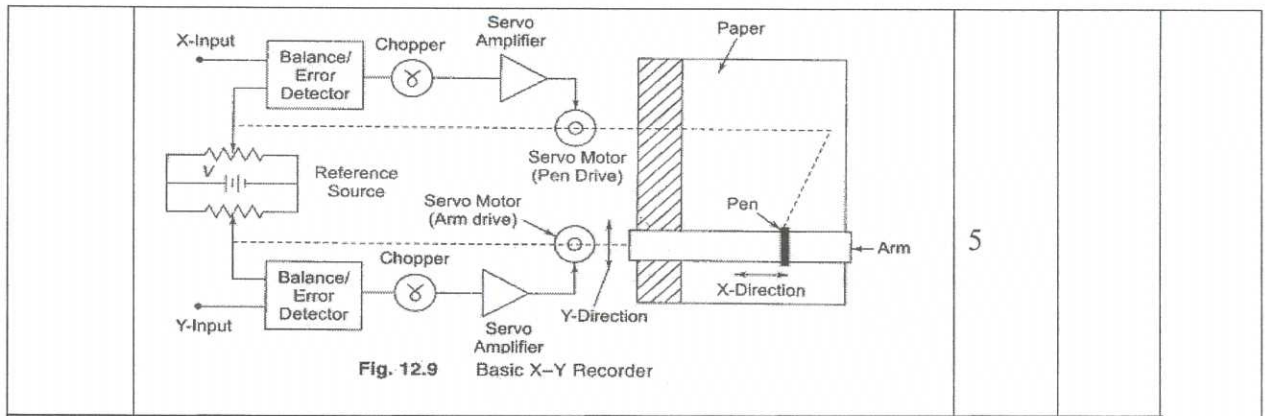

5

IX(b)

Comparison between Open loop & Closed loop Gain

Open Loop System	Closed Loop System
<ol style="list-style-type: none"> 1. An open loop system has the ability to perform accurately, if its calibration is good. If the calibration is not perfect its performance will go down. 2. It is easier to build. 3. In general it is more stable as the feed back is absent. 4. If non-linearity's are present; the system operation is not good. 5. Feed back is absent. <p>Example:</p> <ol style="list-style-type: none"> (i) Traffic Control System. (ii) Control of furnace for coal heating. (iii) An Electric Washing Machine. 	<ol style="list-style-type: none"> 1. A closed loop system has got the ability to perform accurately because of the feed back. 2. It is difficult to build. 3. Less Stable Comparatively. 4. Even under the presence of non-linearity's the system operates better than open loop system. 5. Feed back is present. <p>Example:</p> <ol style="list-style-type: none"> (i) Pressure Control System. (ii) Speed Control System. (iii) Robot Control System. (iv) Temperature Control System.

6

6

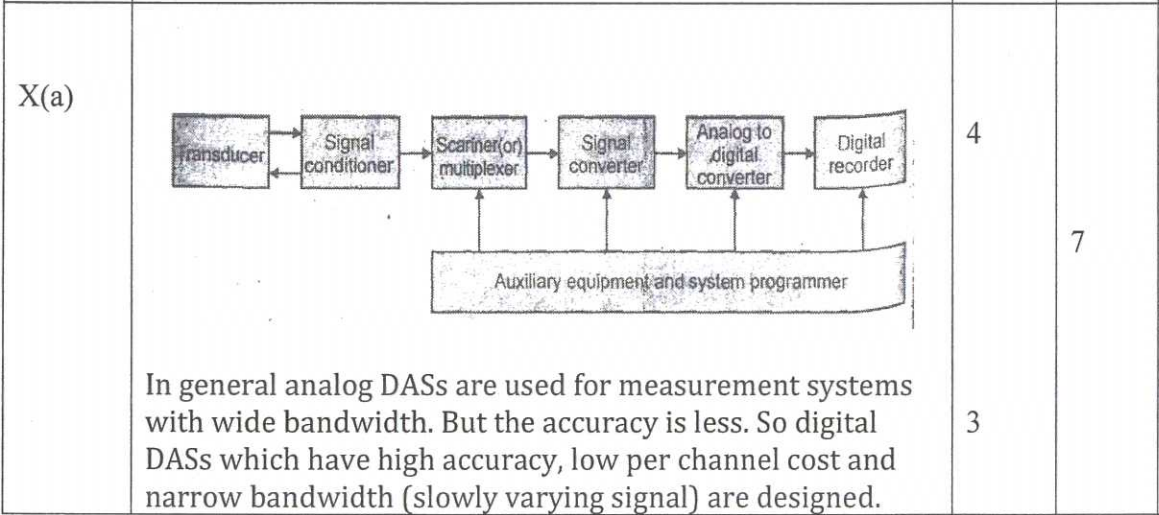

4

7

3

X(b)

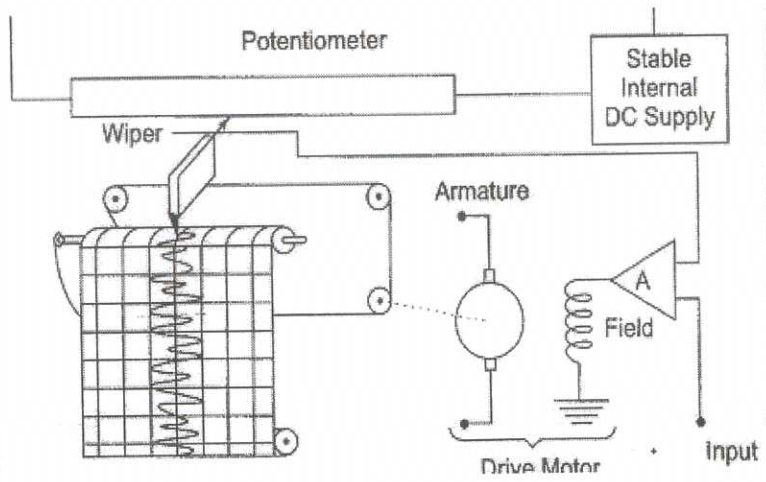

4

8

The Potentiometer is an electric instrument that used to measure the EMF (electro motive force) of a given cell, the internal resistance of a cell. The field coil of the motor is energized by the output of the amplifier. The output of the amplifier is the error signal. The variable arm/slider/wiper of the potentiometer is connected to the armature of the motor. The wiper carries a pen. The paper feed mechanism moves the paper with a constant speed.

4