

SCHEME OF VALUATION

Scoring Indicators

Revision: 2015		Course Code: (15) 5023		
Course Title: Power Plant Engineering				
Qst. No.	Scoring Indicator	Split up score	Sub. Total	Total
I	<u>PART A</u>			
1.	Quantity of heat produced by the complete combustion of unit mass or unit volume of fuel For solid and liquid fuels unit is kJ/kg and for gaseous fuel kJ/m ³	2	2	
2.	Compounding is done to reduce the speed of rotor Steam is allowed to expand in more than one stage	1 1	2	
3.	Function of an air pump is to create vacuum in the condenser. This is done by removing condensable air from the condenser	1 1	2	
4.	Propulsion unit which obtains the oxygen from the surrounding atmosphere for combustion of fuel	2	2	
5.	Moderator is used to reduce neutron energy by collision. It may be in the form of solid, liquid or gaseous	2	2	
II				
1	<ul style="list-style-type: none">• A good fuel should have a low ignition point.• It should have a high calorific value.• It should freely burn with a high efficiency, once it is ignited.• It should not produce harmful gases.• It should produce least quantity of smoke and gases.• It should be economical, easy to store and convenient for transportation.	1 x6	6	

- 2.
- Boiler draught are classified in to two systems Natural draught and Artificial draught
 - Natural draught :- due to difference of densities between hot gases inside the chimney and cold atmospheric air outside it
 - Artificial draught:- it may mechanical or steam jet draught Produced by a fan or blower is known as mechanical draught, produced by steam jet is called steam jet draught

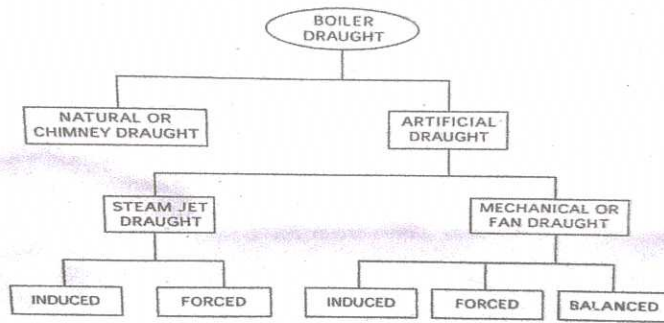

- Balanced draught
- It is combination of both induced and forced draught
- Balanced draught overcomes the draw backs of extinction of fire in forced draught and reduction in effectiveness of draught and combustion in induced draught.

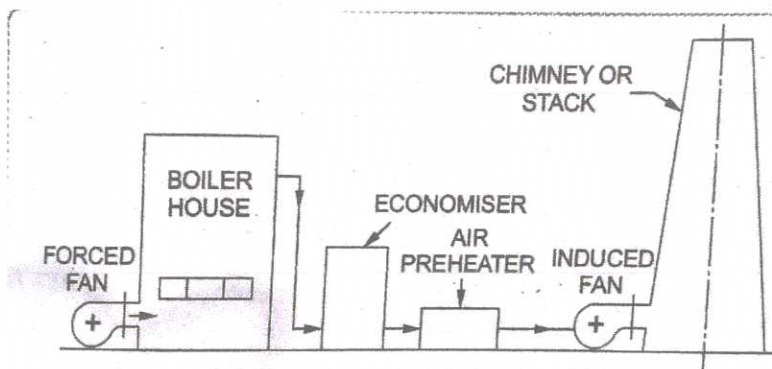

3. Abs pressure in condenser :-
 $760 - 705 = 55 \text{ mm of Hg}$
 $= 55 \times 0.00133 \text{ bar} = 0.073 \text{ bar} \text{ (1mm of Hg} = 0.00133 \text{ bar)}$
 Saturation temperature corresponding to this pressure is $t_s 39.2^\circ\text{C}$ (From tables)
- $$\text{Condenser efficiency } H_e = \frac{t_2 - t_1}{t_s - t_1} = \frac{36 - 29}{39.2 - 29} \times 100 = 68.6 \%$$

1
1
Eqn 2
Subst and answer 2

6

4.

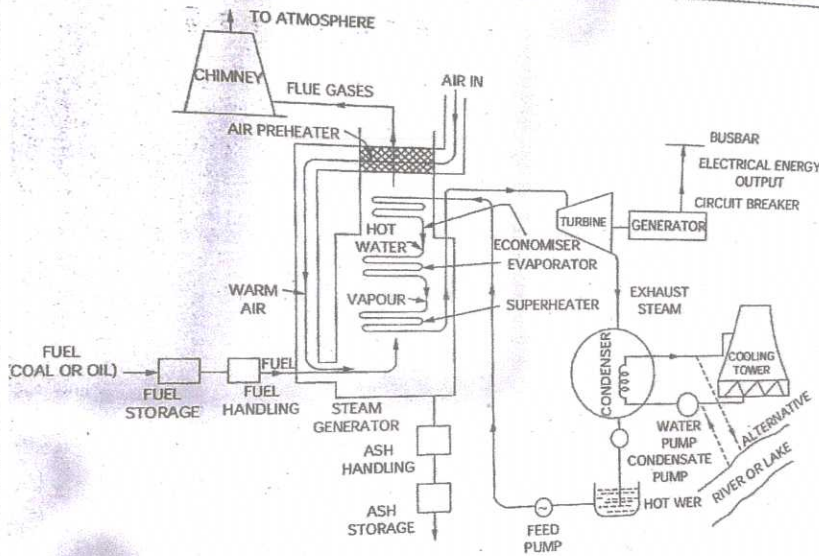

Figure 3
Parts
(6 x 0.5) = 3

6

5.

Sl No	Gas Turbine	Steam Turbine
1.	In gas turbine the compressor and combustion chamber are the important components.	In steam turbine the steam boiler and accessories are the important components.
2.	Less space for installation is required.	More space for installation is required.
3.	The mass of gas turbine per kW produced is less.	The mass of the steam turbine per kW produced is more.
4.	Less installation and running cost.	More installation and running cost.
5.	With the changing load conditions, its control is easy.	Its control is difficult, with the changing load condition.
6.	The starting of this turbine is easy and quick.	The starting of steam turbine is not easy and takes long time.
7.	A gas turbine does not depend on water supply.	A steam turbine depends upon water supply.
8.	Its efficiency is less.	Its efficiency is high.

Any 6 x 1

6

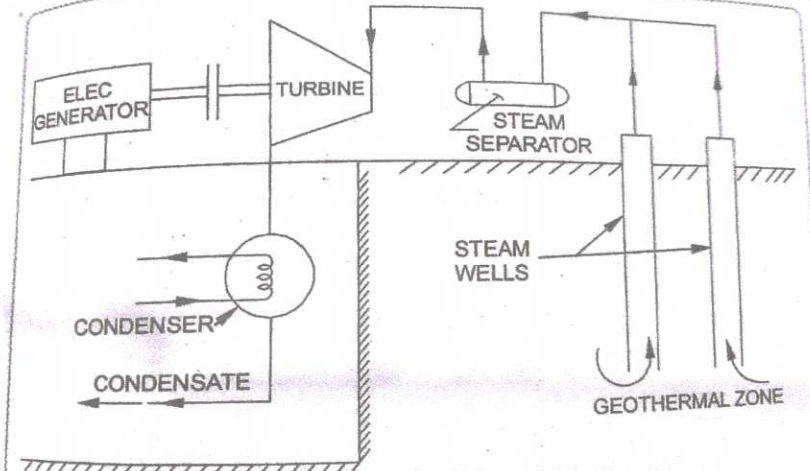
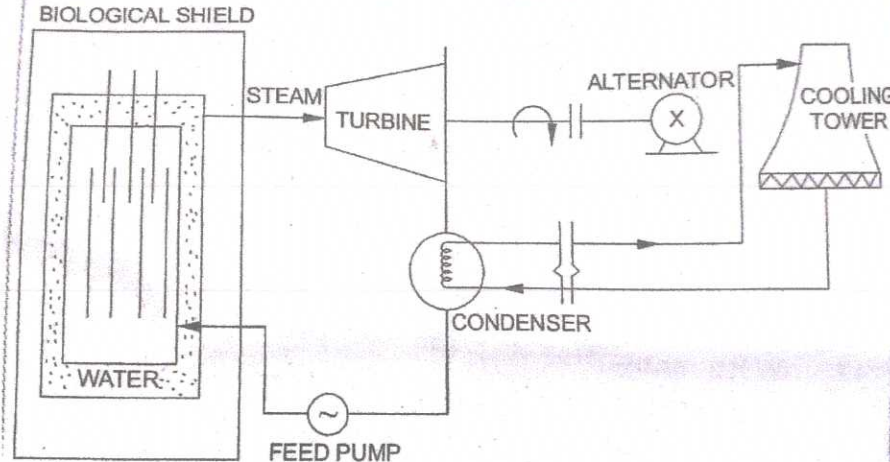
<p>6.</p>	 <ul style="list-style-type: none"> • Steam released through steam wells at a pressure of 30 bars and temperature 200°C to 300°C • Steam separator separates water, pure steam sent to the turbine • Turbine coupled with an electrical generator which produces electrical power 	<p>3</p> <p>1</p> <p>1</p> <p>1</p>	<p>6</p>
<p>7.</p>	 <ul style="list-style-type: none"> • Nuclear fuel is subjected to nuclear fission which produces heat energy • Water surrounding the reactor absorbs this heat and produces steam • Steam passed to a steam turbine and it rotates the electrical generator coupled with turbine • Thus produce electrical energy • Biological shielding is used to reduce radiation intensity 	<p>3</p> <p>3 x 1</p>	<p>6</p>

III.

(a)

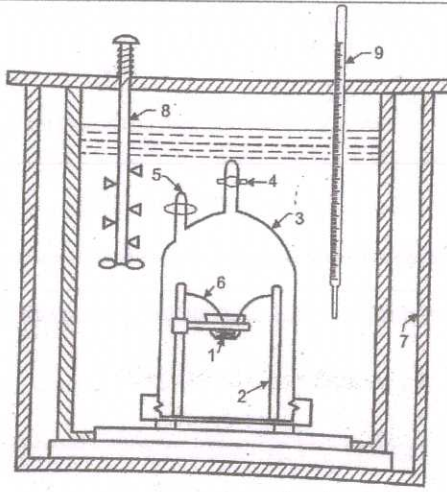

1. Crucible
2. Ignition rods
3. Bomb
4. Oxygen Valve
5. Release Valve
6. Fuse (Ignition) Wire
7. Insulated copper vessel
8. Stirrer
9. Thermometer

3

H.C.V of solid and liquid fuels can be experimentally found using Bomb Calorimeter

1 gm of sample of fuel is placed in the crucible

The bomb is a closed stainless steel vessel in which fuel is burnt at constant volume.

The cover of the bomb carries Oxygen valve and a release valve.

There is a fuse (ignition) wire of platinum or nichrome dipping into crucible containing sample of fuel.

The bomb is kept immersed in a measured quantity of water contained in a can which is kept in an insulated copper vessel.

Pure Oxygen is admitted into the bomb through Oxygen valve at 30 atm. of pressure.

The fuse wire is heated up electrically Which immediate ignites the fuel and the fuel burns completely.

The exhaust gases escape through release valve. The heat released during combustion is absorbed by the surrounding water and the apparatus itself.

Water is kept stirring by a motor driven stirrer and thermometer records temperature rise. When temperature is found to be steady it is noted.

The calorimeter gives H.C.V because steam cannot escape and is condensed and hence heat is recovered from it when products are cooled.

Let m = mass of fuel burnt

M_1 = mass of water

M_2 = Water equivalent of calorimeter

= mass of calorimeter X specific heat of calorimeter

θ_1 = initial temperature of water

θ_2 = final temperature of water

$\Delta\theta$ = Rise in temperature = $(\theta_2 - \theta_1)$

Heat liberated by fuel = $m \times \text{H.C.V}$ kJ

Heat absorbed by the system = heat gained by water + heat gained by calorimeter

$$= M_1 C_{pw} \Delta\theta + M_2 C_{pw} \Delta\theta$$

$$= (M_1 + M_2) C_{pw} \Delta\theta$$

Sp. heat of water = 4.2 kJ/kg K

$$\text{We have, } m \times \text{H.C.V} = (M_1 + M_2) 4.2 \Delta\theta$$

2

7

hence H.C.V = $\frac{(M_1 + M_2) 4.2 \Delta\theta}{m}$ kJ/kg

III
(b)

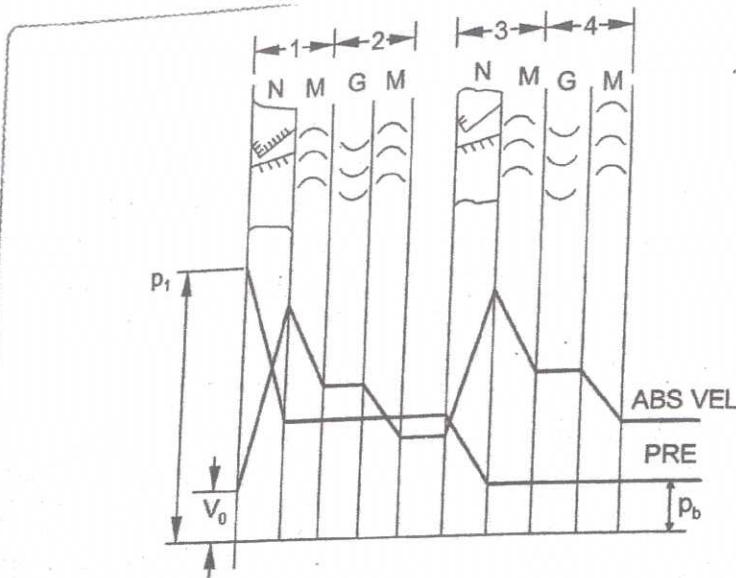

N : Nozzle M : Moving blades G : Guide blades p_1 : Boiler pressure
 p_b : Exhaust pressure v_0 : Initial velocity 1, 2, 3, 4 stages

- This method involves combination of pressure Compounding and velocity compounding.
- The total pressure drop ($p_1 - p_b$) is divided into stages and the Velocity obtained in each stage is also compounded
- Pressure drop in each stage being considerably high, less number of stages are necessary for a given output.
- Thus size of the pressure - velocity compounded turbine is comparatively smaller.
- The diameter of the turbine increases after each stage so as to accommodate increase of volume of steam.
- This method of compounding is used on Curtis and Moore turbine.

4

8

4

IV **Reheating**

(a) In reheating the steam is removed from the turbine when it becomes wet. It is then reheated at a constant pressure by the flue gases, until it is again in the superheated state. It is then returned to the next stage in the turbine.

This will overcome the cause's erosion of the turbine blades and increases internal losses. Also increases the blade efficiency of the turbine.

2

	<p>Bleeding</p> <p>The process of draining steam from the turbine, at certain points during its expansion and using this Steam for heating the feed water (in feed water heaters) and then supplying it to the boiler is known as bleeding, and the corresponding steam is said to be bled.</p> <p>The effects of bleeding are :</p> <ol style="list-style-type: none"> 1. It increases the thermodynamic efficiency of the turbine. 2. The boiler is supplied with a hot water. 3. A small amount of work is lost by the turbine, which decreases the power developed. <p>Regenerating</p> <p>The dry saturated steam, from the boiler, enters the turbine at a higher temperature, and then expands isentropically to a lower temperature in the same way as that in the Rankine and Carnot cycle. Now the condensate, from the condenser, is pumped back and circulated around the turbine casing, in the direction opposite to the steam flow in the turbine. The steam is thus heated before entering into the boiler. Such a system of heating is known as regenerative heating</p>	2	7	
		1		
		2		
IV	<p>Solid Fuels</p> <p>(b) Merits</p> <ol style="list-style-type: none"> (a) They are easy to transport. (b) They are convenient to store without any risk of spontaneous explosion. (c) Their cost of production is low. (d) They possess moderate ignition temperature. <p>Demerits</p> <ol style="list-style-type: none"> (a) Their ash content is high. (b) Their large proportion of heat is wasted. (c) They burn with clinker formation. (d) Their combustion operation cannot be controlled easily. (e) Their cost of handling is high. <p>Liquid Fuels</p> <p>Merits</p> <ol style="list-style-type: none"> (a) They possess higher calorific value per unit mass than solid fuels. (b) They burn without dust, ash, clinkers, etc. 	<p>Any 3 x 0.5 = 1.5</p> <p>Any 2 x 0.5 = 1</p> <p>Any 3 x 0.5 = 1.5</p>	8	

<p>(c) Their firing is easier and also fire can be extinguished easily by stopping liquid fuel supply.</p> <p>(d) They are easy to transport through pipes.</p> <p>(e) They can be stored indefinitely without any loss.</p> <p>(f) They are clean in use and economic to handle.</p> <p>(g) Loss of heat in chimney is very low due to greater cleanliness.</p> <p>(h) They require less excess air for complete combustion.</p> <p>(i) They require less furnace space for combustion.</p>			
<p>Demerits</p> <p>(a) The cost of liquid fuel is relatively much higher as compared to solid fuel.</p> <p>(b) Costly special storage tanks are required for storing liquid fuels.</p> <p>(c) There is a greater risk of fire hazards, particularly, in case of highly inflammable and volatile liquid fuels.</p> <p>(d) They give bad odour.</p> <p>(e) For efficient burning of liquid fuels, specially constructed burners and spraying apparatus are required.</p>	<p>Any 3 x 0.5 = 1.5</p>		
<p>GASEOUS FUELS</p> <p>Merits</p> <p>(a) They can be conveyed easily through pipelines to the actual place of need, thereby eliminating manual labour in transportation.</p> <p>(b) They can be lighted at ease.</p> <p>(c) They have high heat contents and hence help us in having higher temperatures.</p> <p>(d) They can be pre-heated by the heat of hot waste gases, thereby affecting economy in heat.</p> <p>(e) Their combustion can readily be controlled for change in demand like oxidizing or reducing atmosphere, length flame, temperature, etc.</p> <p>(f) They are clean in use.</p> <p>(g) They do not require any special burner.</p> <p>(h) They burn without any shoot, or smoke and ashes.</p> <p>(i) They are free from impurities found in solid and liquid fuels.</p> <p>Demerits</p> <p>(a) Very large storage tanks are needed.</p> <p>(b) They are highly inflammable, so chances of fire hazards in their use are high.</p>	<p>Any 3 x 0.5 = 1.5</p> <p>2 x 0.5 = 1</p>		

V
(a)

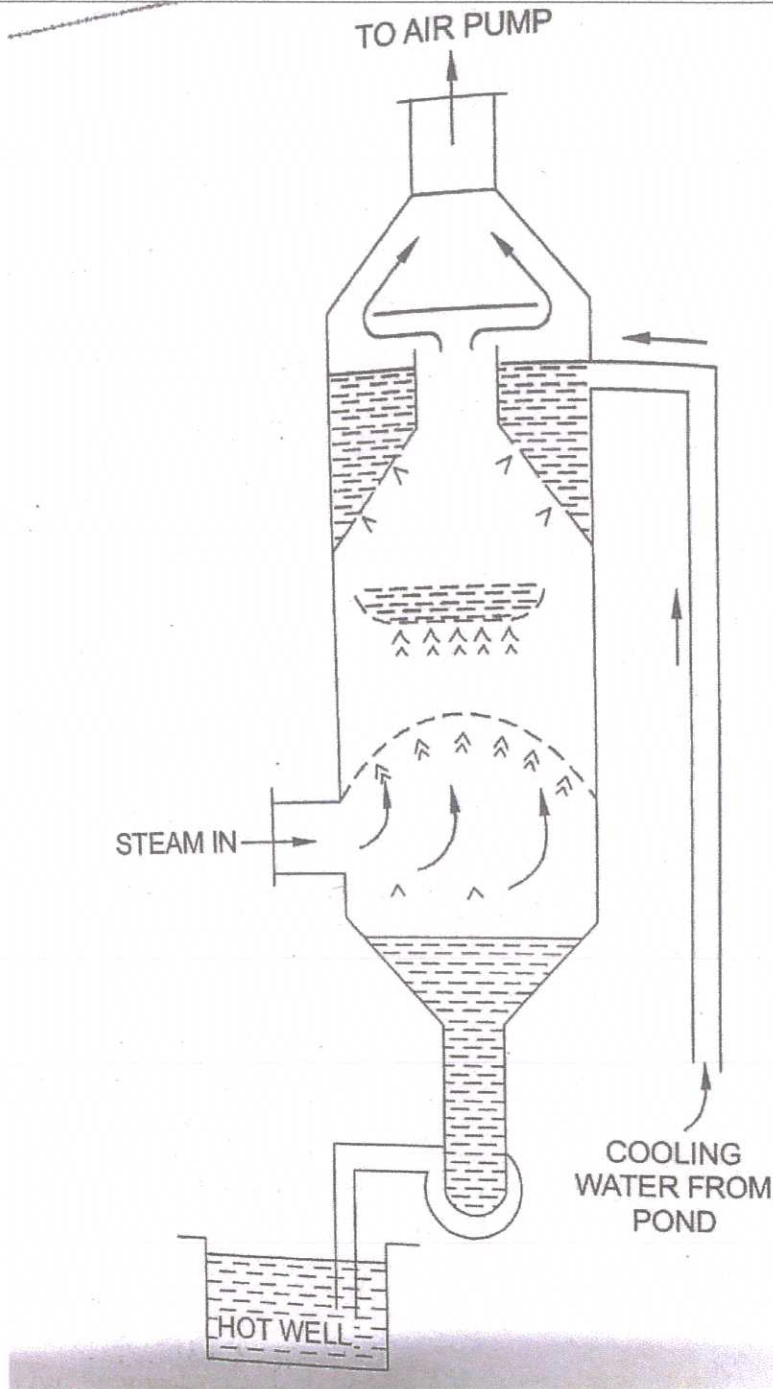

4

7

- In a Counter Flow Low Level Jet Condenser steam enters at the bottom of the shell while water is admitted at the top and sprayed downwards.
- Steam falling downwards comes in contact with water and gets condensed.
- Perforated conical plate issues jets of water which further break up in the perforated tray as shown in figure.

3 x 1 = 3

V
(b)

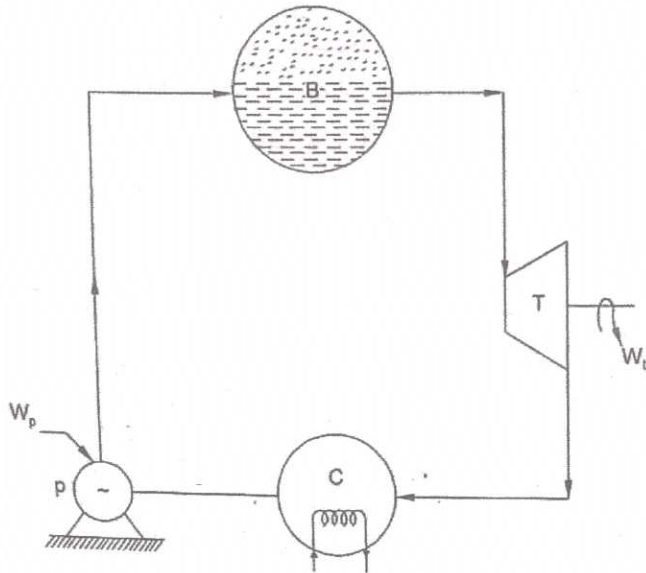

B : Boiler T : Turbine C : Condenser P : Water Pump

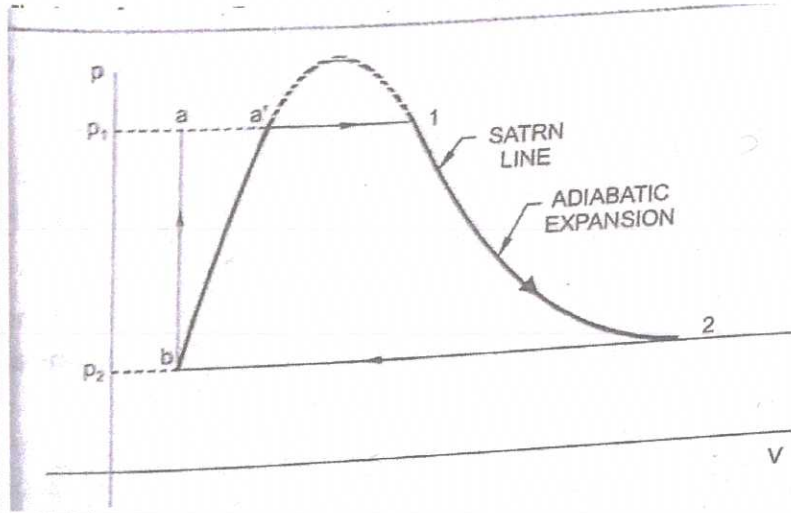

P-V Diagram

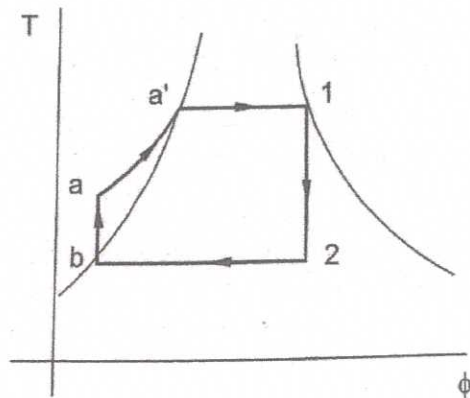

T-φ Diagram

2

8

1

1

	<p>The ideal cycle consists of the following processes :</p> <p>1-2: Adiabatic (isentropic) expansion of steam in engine or turbine (prime mover). Work is done by steam on turbine blades. It is given by, $w_t = H_1 - H_2$ are enthalpies at p_1 and p_2.</p> <p>2-b Condensation of steam at constant temperature and pressure to liquid state. Heat rejected is given by $Q_c = H_2 - h_b$ where h_b : liquid enthalpy at p_2 corresponding to point 'b'.</p> <p>b-a : Adiabatic (pumping) or compression of condensate water. Pump work is given by, $W_p = h_a - h_b$ where h_a and h_b are liquid enthalpies at p_1 and p_2 corresponding to states 'a' and 'b'</p> <p>a-1: Sensible heating of water from a to a' and then evaporation from a' to 1 in the boiler at constant pressure. Heat supplied is given by, $Q_s = H_1 - h_b$ kJ/kg per cycle</p>	4 x 1 = 4	
VI (a)	<p>$P_1 = 15$ bar $P_2 = 0.5$ bar</p> <p>1) $T_1 = 198.3 + 273 = 471.30$ K at p_1 from tables $T_2 = 81.35 + 273 = 354.35$ K at p_2 from tables</p> $\eta_{\text{carnot}} = 1 - \frac{T_2}{T_1} = 1 - \frac{354.35}{471.30} = 1 - .7518 = .2482 \times 100 = \mathbf{24.82\%}$ <p>2) $T_1 = 300 + 273 = 573$ K, $T_2 = 354.35$ K</p> $\eta_{\text{carnot}} = 1 - \frac{T_2}{T_1} = 1 - \frac{354.35}{573} = 1 - .6184 = .3816 \times 100 = \mathbf{38.16\%}$	<p>1 Eqn 1 Substitution and answer 2</p> <p>1 Substitution and answer 2</p>	7

$$\eta_{\text{carnot}} = 1 - \frac{T_2}{T_1} = 1 - .6184 = .3816 \times 100 = 38.16\%$$

and answer 2

VI (b)		Jet Condenser.	Surface Condensers	8 x 1	8
	1	Contact between steam and cooling water is direct. They form a mixture of condensate and water after heat exchange.	Exhaust steam and cooling water do not come in to contact directly. Condensate and circulating water never mix together.		
	2	Condensate is not fit for reuse as boiler feed water since circulating water contains impurities.	Condensate is quite fit for reuse as boiler feed water.		
	3	Vacuum rarely exceeds 650 mm of mercury.	Very high vacuum can be created. So higher plant efficiency.		
	4	Quantity of cooling water is less.	Larger quantity of cooling water is required.		
	5	Less maintenance cost.	Maintenance cost is high.		
	6	Low manufacturing cost.	High manufacturing cost.		
	7	Requires less floor area.	Requires large floor area		
	8	More auxiliary power is required.	Less auxiliary power is required		
VII (a)				3	7
<p>C - Compressor, CC- Combustion Chamber, T- Turbine, P- Propeller, S - Coupling Shaft, D - Diffuser.</p> <ul style="list-style-type: none"> A turbo-propeller unit obtains its driving or propulsive force from the action of propeller as well as from the reaction of the jet of burnt gases ejecting from its rear. It is also known as 'turbo-propengine'. 			4		

- Here the expansion of gases takes place partly ($\approx 80\%$) in nozzle.
- Air enters the compressor where it is compressed to a high pressure.
- The compressed air is then passed into combustion chamber where combustion of fuel takes place.
- The products of combustion are, thereafter, forced into the gas turbine.
- Power is developed by the turbine which drives the propeller and compressor. The exhaust gases form into a jet and leave the unit from its rear end.

VII
(b)

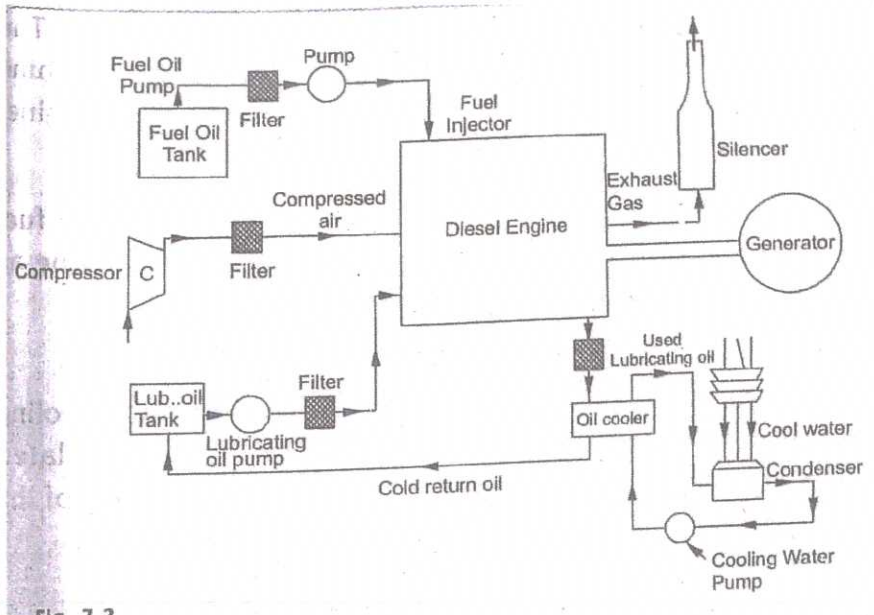

Engine :

Engine is the main part of a diesel power plant. Engine is directly connected through a gear box to the generator.

Air supply system :

Air inlet is arranged outside the engine room. Air from the atmosphere is filtered by air filter and conveyed to the inlet manifold of engine.

Exhaust System

This includes the silencers and connecting ducts.

Fuel System :

Fuel is stored in a tank from where it flows to the fuel pump through a filter. Fuel is injected to the engine as per the load requirement.

Cooling system :

Cooling water is circulated through the engine block to keep the temperature of the engine in the safe range.

Lubricating system :

Lubricant is given to reduce friction of moving parts and reduce the wear and tear of the engine parts.

Starting System :

For starting the power plant we can employ different auxiliary systems which are An auxiliary engine or electric motor or use of compressed air from compressor.

4

8

Any 4 x 1

Governing system :

The function of a governing system is to maintain the speed of the engine constant irrespective of load n the plant. This is done by varying fuel supply according to the load.

VIII
(a)

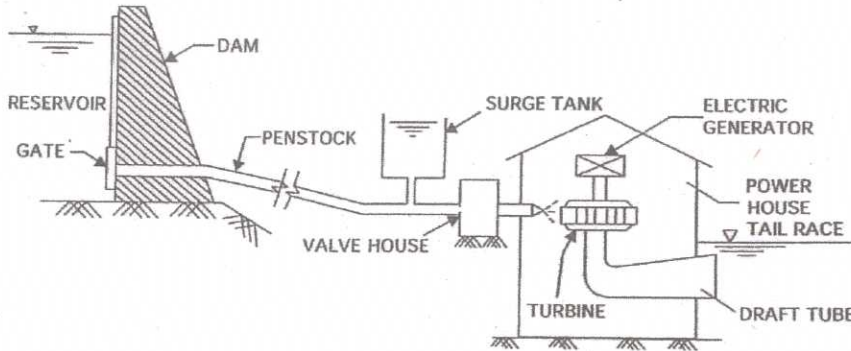

HEAD RESERVOIR :

The head reservoir is the reservoir that stores the required quantity of water for running the turbines. The water level in the storage reservoir is known as the head race.

DAM ACROSS THE RIVER/STREAM WITH THE CONTROL WORKS.

A dam of masonry or concrete constructed across the river/stream will enable storing the required quantity of water.

PENSTOCKS AND GATE VALVES :

Penstocks are large diameter pipes made of steel or concrete to carry water from the head reservoir to the turbines.

SURGE TANK :

A small Open tanks known as Surge Tanks are provided close to the turbine. Mitigate the water hammer action in the penstock, Supply additional quantity of water when over load comes on,

GOVERNING MECHANISM .

Is provided to regulate the flow to the turbine.

GENERATION AND TRANSMISSION EQUIPMENT :

These consist of transformers, switching equipment, switch gears, safety equipments and transmission lines and towers etc., to carry the power to the consumers.

TAIL RA CE AND DIVERSION ARRANGEMENT.

The tail race is the level at which the water leaves the turbines. '

3

7

Any 4 x 1

(b)

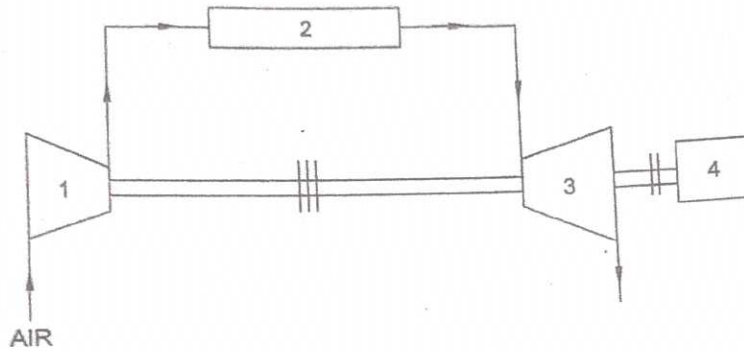

1. Compressor 2. Combustion Chamber 3. Turbine 4. Generator

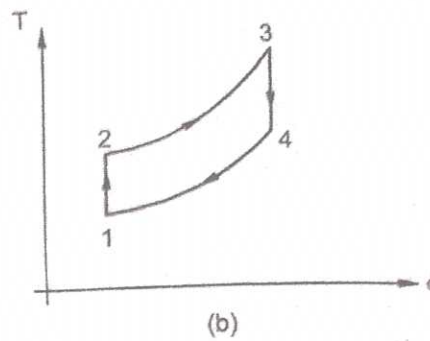
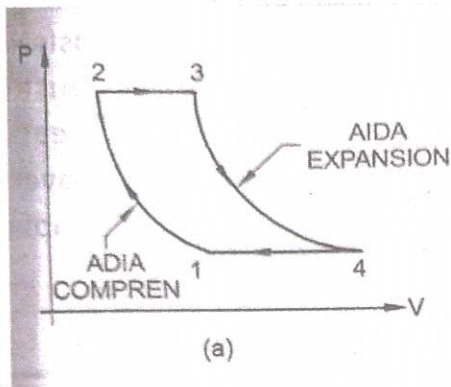

This is a turbine in which fuel is burnt and air is heated at constant pressure in a combustion chamber.

Air is drawn from atmosphere and is compressed in a multi-stage compressor. The compressed air passes into a combustion chamber where fuel is injected into it.

A portion of this air is burning the fuel and rest of the air gets mixed up with the products of combustion thus reducing the temperature of products.

The mixture of air and combustion products enters the turbine forming a jet to impinge on turbine blades.

As the gases expand over the blades the pressure energy is converted into kinetic energy.

The K.E is absorbed by the turbine rotor and thus power is developed.

The expanded gases are exhausted into atmosphere.

2

8

2

4

IX
(a)

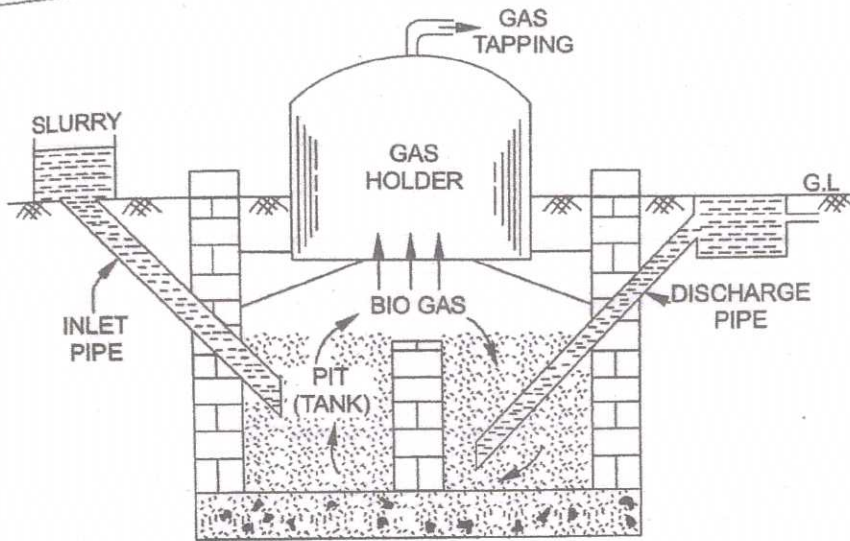

- Bio gas may be defined as the mixture of methane (CH_4) and carbon dioxide (CO_2) with traces of hydrogen sulphide (H_2S). It is produced by anaerobic digestion from animal dung, human excreta and green plants.
- figure shows the cross sectional view of a bio gas plant.
- It contains a pit (1.5 to 1.6 m dia., and 4.0 to 6.0 m deep) excavated below the ground level. It is lined with bricks. The partition wall divides the space in pit into two compartments. The bottom of the pit is finished with cement concrete basement.
- Two slanting cement pipes reach the bottom of the pit on either side of the partition.
- One pipe conveys slurry of biomass from inlet into the pit and the other pipe discharges the slurry (after digestion) to the sludge outlet.
- The outlet pipe dips lower into the pit than inlet pipe.
- During decomposition of biomass slurry it liberates methane.
- Uses : The biogas ($\text{CH}_4 + \text{CO}_2$) is used as a fuel for domestic purpose and rural electrification..

4

7

3

IX

(b)

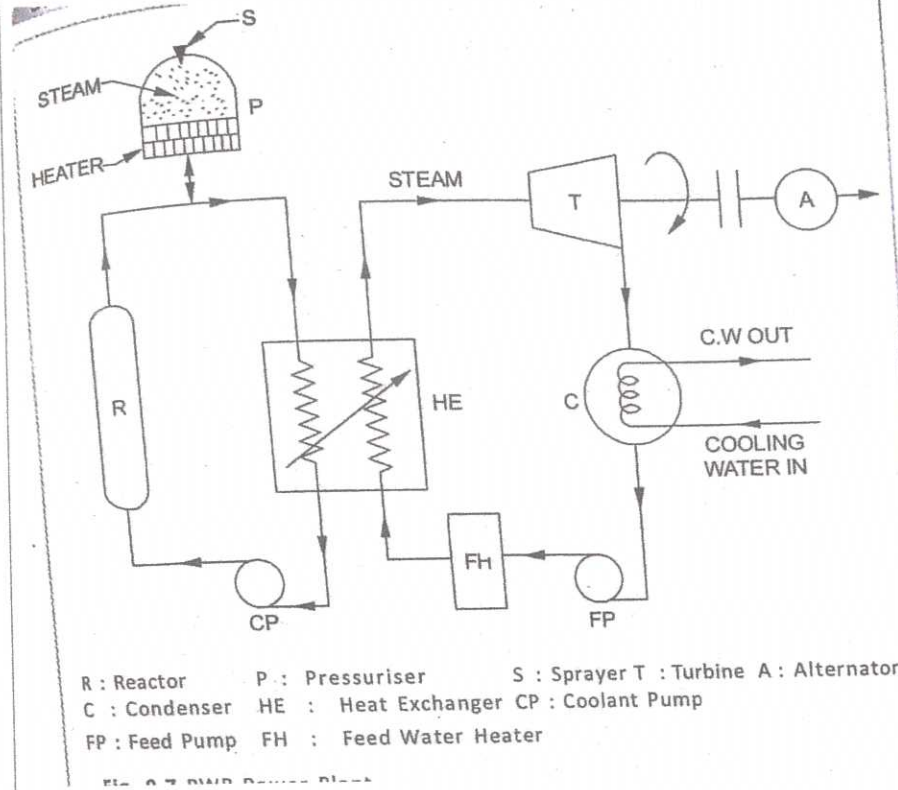

4

The coolant in the primary circuit gets heated by absorbing the heat energy liberated in the reactor core due to nuclear fission.

The hot liquid flows to the heat exchanger via a 'pressurizer'.

'Pressurizer' located in the primary circuit of the plant is a vessel with a heater at its bottom and water spray at its top. The top of this vessel is filled with steam at primary circuit pressure.

If primary circuit pressure drops, then the heater is operated which generates steam and increases the steam content in the vessel. This results in increase the pressure. On the other hand, if primary circuit pressure becomes too high, then the cold water is sprayed into the steam through the sprayer. This condenses the steam and reduces the primary circuit pressure.

In the heat exchanger the hot liquid of primary circuit loses its heat to feed water of secondary circuit. Feed water evaporates into steam and passes into the turbine. Turbine being coupled to the alternator helps generation of electric power.

Exhaust steam from the turbine is condensed in the steam condenser and the condensate is recalculated as feed water. This is called secondary circulation. The coolant leaving the heat exchanger is pumped back to the reactor as shown figure

4

8

X

(a)

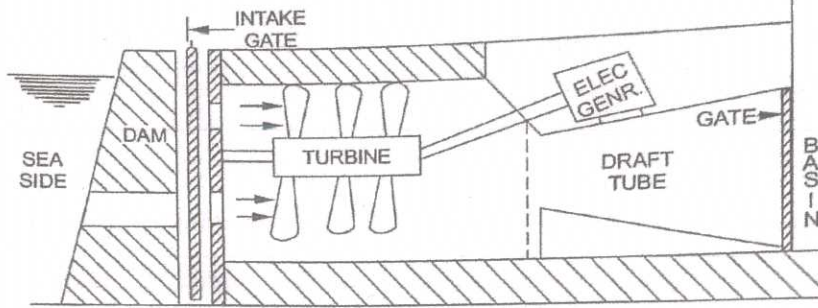

Three main components of a Tidal power plant are

- a dam or barrage (low wall) to form a pool or basin. 4
- sluice ways from basin to sea and vice versa.
- power house (turbines, electrical generator and other accessories).

The dam serves as a barrier between the sea and the basin or between one basin or and the other. 7

The sluice ways are used either to fill the basin during the high tide or empty the basin during the low tide. These are gate controlled devices.

The main feature of the tidal cycle is the difference in water surface elevation at the high tide and the low tide. This differential head is utilised in operating a hydraulic turbine. 4

In principle, at the time of high tide, water will be at high level and it is let into a basin to be stored at a high level there. Since the basin water level is high and sea water level is low, there is a differential head that can be utilised for running the turbines.

Turbines used in a tidal power plant are reversible type so that they can work as pumps also to pump water out from basin to sea during low tide period.

Turbines are coupled to electrical generators which produced electrical power.

<p>X (b)</p>	<p>Nuclear fission is the splitting of a heavy nucleus into two lighter ones and enormous heat energy is liberated</p> <p>Nuclear chain reaction: - A typical nuclear fission reaction, more than one neutron is released by each dividing nucleus. When these neutrons collide with and induce fission in other neighboring nuclei, a self-sustaining series of nuclear fission reactions called nuclear chain reaction</p> <p>Nuclear fusion, in which two light nuclei combine to produce a heavier, more stable nucleus, is the opposite of nuclear fission, fusion produces more heat energy than fission reaction</p> <p>Nuclear fission is controlled by using control rods</p> <p>To maintain a sustained controlled nuclear reaction a neutron absorbing element must be present to control the amount of free neutrons in the reaction space. Most reactors are controlled by means of control rods that are made of a strongly neutron-absorbent material such as boron or cadmium</p>	<p>2 X4</p>	<p>8</p>	
------------------	---	-------------	----------	--