

SCHEME OF VALUATION
(Scoring Indicators)

Revision: 2015

Course Code: Rev(15) 6025

Course Title: Industrial automation & Mechatronics

Qst. No	Scoring Indicator	Split up score	Sub Total	Total
	PART A			
I 1.	Automatically controlled operations of an apparatus, process or systems by mechanical or electronic devices that replace human observations, effort and decisions			2 Marks
2.	Higher quality, reliability and productivity & cost effective High degree of flexibility Great extent of machine/mechanism utilisation High performance characteristic			Any 2 1x2 = 2m
3.	Convert energy from one form to another Detect or sense the presence, magnitude and changes in physical quantity being measured			2
4.	An actuation system contains control systems which are responsible for transforming the output of a micro processor or control system into a controlling action on a machine or device.			2
5.	A number of internal relays can be grouped together to form a register which can provide a storage area for a series sequence of individual bits			2

SCHEME OF VALUATION
(Scoring Indicators)

Revision: 2015

Course Code: Rev0526025

Course Title: Industrial automation & Mechatronics

II

Qst. No	Scoring Indicator	Split up score	Sub Total	Total
1	<p><u>PART B</u></p> <p>a) Increased productivity b) Decreased Labour cost / Labour shortage c) Improved product quality / delivery d) Safety and Reliability</p>			
			$1 \times 6 = 6$ Marks	
2.	<p>Mechanical systems</p> <p>Layout 3</p> <p>Explanation 3</p>			
3.	<p>The behaviours of a systems subjected to inputs that do not vary with time is termed as <u>Static characteristics</u> of a system</p> <p>The input signal vary with time and so does its output called <u>Dynamic characteristics</u>.</p>			

4. When a mechanical switch is switched to close the contacts, one contact being moved towards the other. It hits the other and, because the contacting elements are elastic, bounces. When a mechanical switch is opened, bouncing can occur.

115. Directional Control valves control the flow of a fluid in an hydraulic system. A common type of directional control valve is spool valve. The spool moves horizontally within the valve body to control the flow.

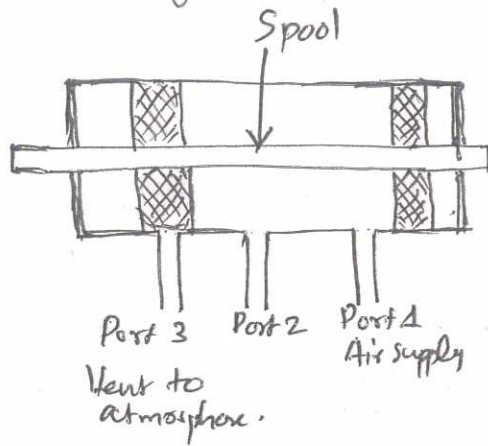

Explanation 3

Sketch 3 6 marks

6. D.C. Motors.	A.C. Motors.
<ol style="list-style-type: none"> 1. Position control element 2. Speed control systems 3. High starting torque 4. Speed depends upon the current through armature coil 5. Pulse Width Modulation (PWM) is used for varying voltage. 6. Commutator and brushes required leads wear & tear 7. D.C. Motors are costly 	<ol style="list-style-type: none"> 1. Position controls 2. Controls the speed 3. Low starting torque. 4. Speed control achieved by variable frequency supply. 5. An AC/DC rectifier used to maintain constant torque in an AC motor. 6. No scrub wear & tear of brushes and commutator. 7. AC Motors are cheaper Reliable & Maintenance free 4x6 = 6 marks

7. i) It has interfacing with inputs as well as outputs signals inside the controller.

ii) Programming is very easy.

iii) They are designed to with stand vibrations, temperature, humidity and noise

3x2 = 6 marks

PART - C

- III a) Types of automation
- i) Fixed Automation.
 - ii) Programmable automation
 - iii) Integrated automation

b) Home appliances : Explanation $3 \times 3 = 9$
Washing machine
Air conditioners
Mixer/Grinders

Automobile : Fuel injection (MPFI)
: Anti lock Braking System (ABS)

Manufacturing : CNC Machine.
Robots. $3 \times 2 = 6$ marks.

IV a) Open loop control systems.

This is a non feedback control system.

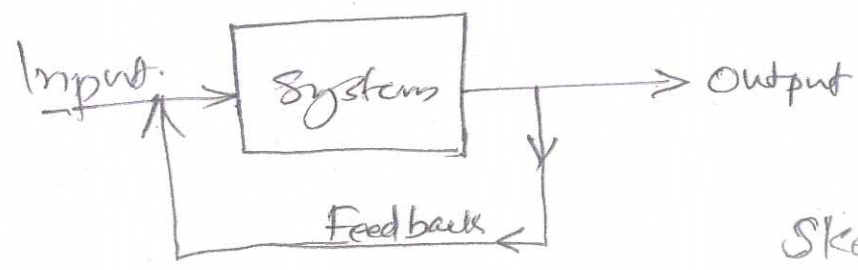
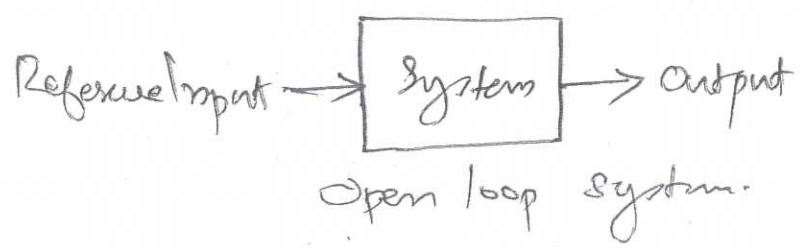

Sketch $2 \times 2 = 4$
Explanation $5 = 5$ } 9

IV b) ^{automation system} Traditional Design	Automation System ^{Mechatronic Design}
<ol style="list-style-type: none"> 1. Complicated Process. 2. Interaction required between many skills and disciplines. 3. Traditional components are using 4. Circuits and components are parts of design. 5. Little precise & accuracy 6. Design param is not flexible 	<ol style="list-style-type: none"> 1. Not much complicated. 2. System itself integrates between disciplines. 3. Advanced mechatronic aparts replaces the traditional one. 4. Micro controllers and micro processors are using. 5. High precision & accuracy. 6. Highly flexible and freedom

6x1 = 6 Marks

V a. Performance terminology

- i) Range & span.
- ii) Error.
- iii) Accuracy.
- iv) Sensitivity
- v) Hysteresis error.
- vi) Non-linearity error
- vii) Repeatability or Reproducibility
- viii) Stability
- ix) Dead band time or Dead space
- x) Resonance
- xi) Output impedance

Any 9x1 = 9 Marks.

V b) An Encoder is a device that provides digital output as a result of linear or angular displacement.
 Basically 2 types i) Incremental Encoder ii) Absolute encoder.

V (b) continues.

INCREMENTAL ENCODER :

The Fig. shown the basic form of an incremental encoder for the measurement of angular displacement.

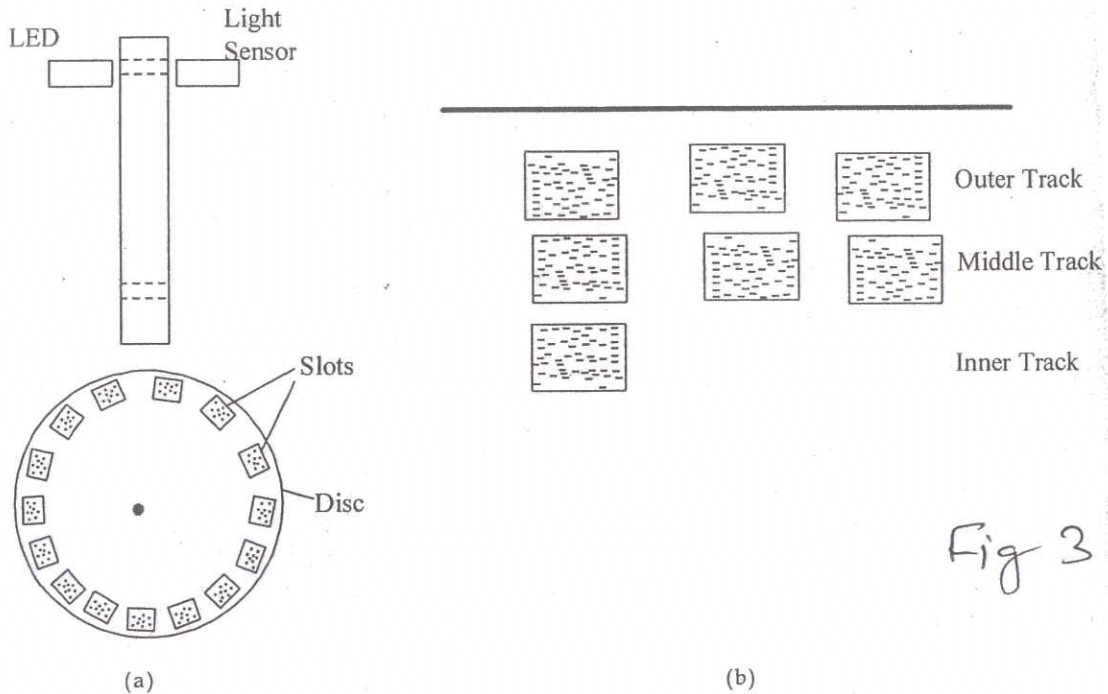

Fig 3 marks

Note : LED Means Light Emitting Diode

Fig. (a) shows the basic principle of an incremental encoder. A beam of light coming from the LED passes through slots in a disc and is detected by a suitable light sensor.

When the disc is rotated with the help of shaft a pulsed output is produced by the sensor with the no. of pulses. Thus the angular position of the disc can be measured by the no of pulses produced since some datum position.

Fig. (b) shows the practical optical encoders, in this three concentric tracks with the tracks used are outer tracks, middle track and inner track. The inner track has one hole and it is used to located the home position of the disc. The remaining two tracks have a series of equally spaced holes that go completely round the disc but with the holes in the middle track offset from the design the outer track by one-half the width of a hole. This offset enables the direction of rotation to be determined. In the clockwise direction the pulses in the outer track lead those in the inner, in the anti clock wise direction they lag.

Explanation: 3 Marks

P. 6/14

Practical 6 Marks

VI a). Selection of Sensors - Factors.

The following are the factors to be considered.

- i) Mechanical stability (Size/Weight/Shape & Mounting)
- ii) Electrical suitability
(Voltage, Current, Frequency, Sensitivity etc)
- iii) Environmental suitability
(Dust, Vibration, Humidity, Magnetic fields, Temperature...)
- iv) Performance ~~for~~ (calibration)
- v) Desired measurement (accuracy, range, power require, OLP or vulnerability to sudden change)
- vi) Complexity (Mechanism & wiring)
- vii) Purchase aspects (Availability, delivery etc).

VI b). Temperature Sensing Elements. Any 4/5 Points = 2 Marks

These are transducers which are thermally sensitive variable resistors made of certain conducting and ceramic like semi conducting materials. They are used as temperature detecting element used to sense temp. for the purpose of measurement and control.

The following are the some of methods that are commonly used with temperature control system.

- i) Bimetallic strips
- ii) Resistance temperature Detectors (RTDs)
- iii) Thermistors.
- iv) Thermo couple.

Name 2x1 = 2 marks

Explanation 4x1 = 4 marks

6 Marks

VII a)

PRESSURE CONTROL VALVES :

There are three main types of pressure control valves.

1. Pressure regulating valves :

These are used to control the operating pressure in a circuit and maintain it at a constant value.

2. Pressure limiting valves :

These are used as safety devices to limit the pressure in a circuit to below some safe value. The valve opens and vents to the atmosphere, or back to the sump, if the pressure rises above the set safe value.

3. Pressure sequence valves :

These valves are used to sense the pressure of an external line and give a signal when it reaches some preset value.

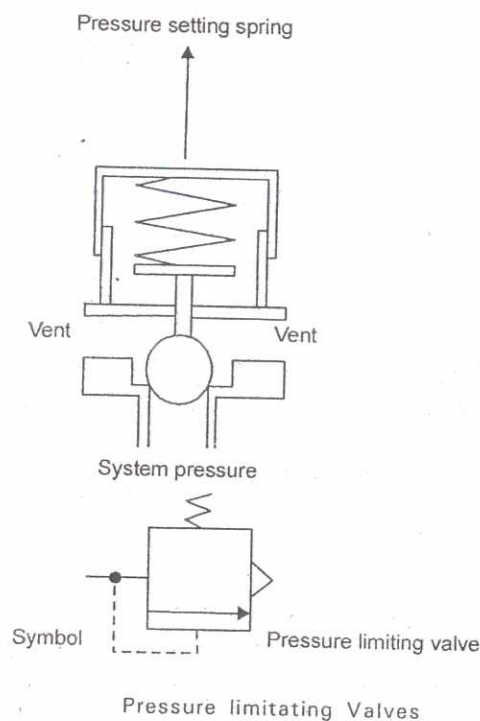

Classification: 3 marks.

Pressure limiting valve :

Figure shows a pressure limiting relief valve which has one orifice which is normally closed. when the inlet pressure overcomes the force exerted by the spring, the valve opens and vents to the atmosphere, or back to the sump. This can be used as a pressure relief valve to safeguard a system against excessive pressures.

Explanation: 6 marks

Total
9 marks

P. 8/14

VII b) Rotary actuators:

A linear cylinder can, with suitable mechanical linkages, be used to produce rotary movements through angles less than 360° . Fig(1)

Another alternate is a semi-rotary actuator involving a vane Fig(2). A pressure difference between the two parts causes the vane to rotate and so give a shaft rotation which is the measure of the pressure difference.

For rotation through angles greater than 360° a pneumatic motor can be used; one form of such is the vane motor Fig. 3. An eccentric rotor has slots in which vanes are forced outwards against the walls of the cylinder by the rotation. The vanes divide the chamber into separate compartments which increase in size from the inlet port round to the exhaust port. The air entering such a compartment exerts a force on a vane and causes the rotor to rotate. The motor can be made to reverse its direction of rotation by using a different inlet port.

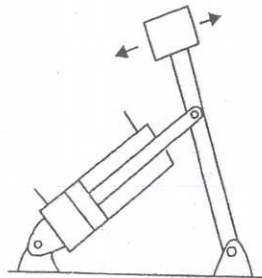

Fig(1) A linear cylinder used to produce rotation

Explanation: 3 Marks
(Anyone)

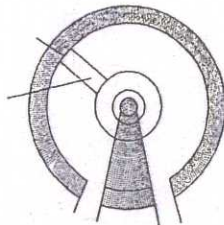

Fig(2) Vane type semi rotary actuator

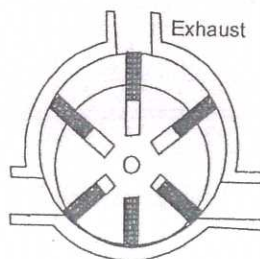

Fig. 3 Vane motor

Figure (Anyone) — 3 marks

Total 6 Marks

VIII (a)

Stepper Motors :

The **stepper motor** is a device that produces rotation through equal angles, the so-called **steps**, for each digital pulse supplied to its input. Thus, for example, if with such a motor 1 pulse produces a rotation of 60° then 60 pulses will produce a rotation-through 360° . There are a number of forms of stepper motor.

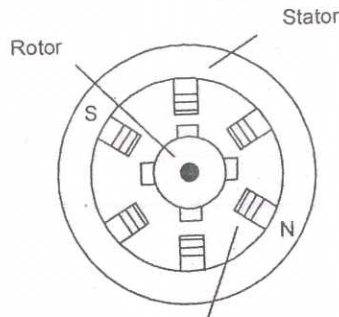

(a) This Pair of Pole Energised by Current being Switched them and Motor Rotates to Position

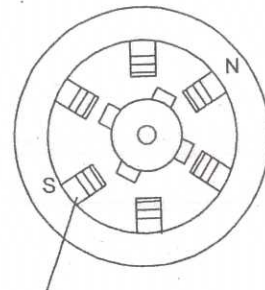

(b) This Pair of Poles Energised by Current being Switched to them to give Next Step

FIG(1)

Brief description : 3 marks.

Explanation mark : 6 Marks

Variable Reluctance Stepper :

Fig. (1) shows the basic form of the variable reluctance stepper motor. With this form the rotor is made of soft steel and is cylindrical with four poles, i.e. fewer poles than on the stator. When an opposite pair of windings has current switched to them, a magnetic field is produced with lines of force which pass from the stator poles through the nearest set of poles on the rotor. Since lines of force can be considered to be rather like elastic thread and always trying to shorten themselves, the rotor will move until the rotor and stator poles line up. This is termed the position of minimum reluctance. This form of stepper generally gives step angles of 7.5° or 15° .

9 marks

Permanent Magnet Stepper :

Fig. (2) shows the basic form of the permanent magnet motor. The motor shown has a stator with four poles. Each pole is wound with a field winding, the coils on opposite pairs of poles being in series. Current is supplied from a d.c. source to the windings through switches. The rotor is a permanent magnet and thus when a pair of stator poles has a current switched to it, the rotor will move to line up with it. Thus for the currents giving the situation shown in the Fig. the rotor moves to the 45° position. If the current is then switched so that the polarities are reversed, the rotor will move a further 45° in order to line up again. Thus by switching the currents through the coils the rotor rotates in 45° steps. With this type of motor, step angles are commonly 1.8° , 7.5° , 15° , 30° , 34° or 90° .

P. 10/14

VIII a) continues

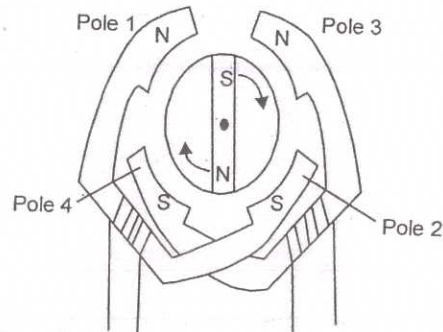

FIG(2) Permanent Magnet Stepper Motor

Hybrid Stepper :

Hybrid stepper motors combine the features of both the variable reluctance and permanent magnet motors, having a permanent magnet encased in iron caps which are cut to have teeth Fig. (3) The rotor sets itself in the minimum reluctance position in response to a pair of stator coils being energised. Typical step angles are 0.9° and 1.8° . Such stepper motors are extensively used in high-accuracy positioning applications, e.g. in computer hard disc drive.

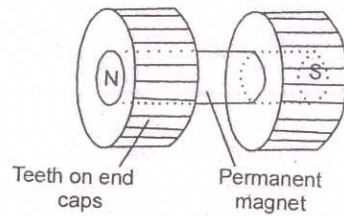

FIG(3) Hybrid Motor Rotor

VIII b. Mechanical switches.

Mechanical switches are elements which are used as sensors to give input to a system.

Eg: Keyboard, Electrical relay etc.

3 marks.

Solid state switches

i) Diode

ii) Thyristors and triacs.

iii) Bipolar Transistors. (4) Power MOSFETs. 3 marks

Total 6 Marks

IX a)

CPU (central processing unit) :

It controls and processes all operations within the PLC. It is supplied with a clock with a frequency of typically between 1 and 8 MHz which determines the speed of the PLC and provides the timing synchronization for all elements in the system.

Bus system : This constitute of Address bus, control bus databus and I/O system bus. This system carries information and data to and from the CPU and other elements.

A system ROM (Read only Memory) : It gives permanent storage for the operating system and fixed data.

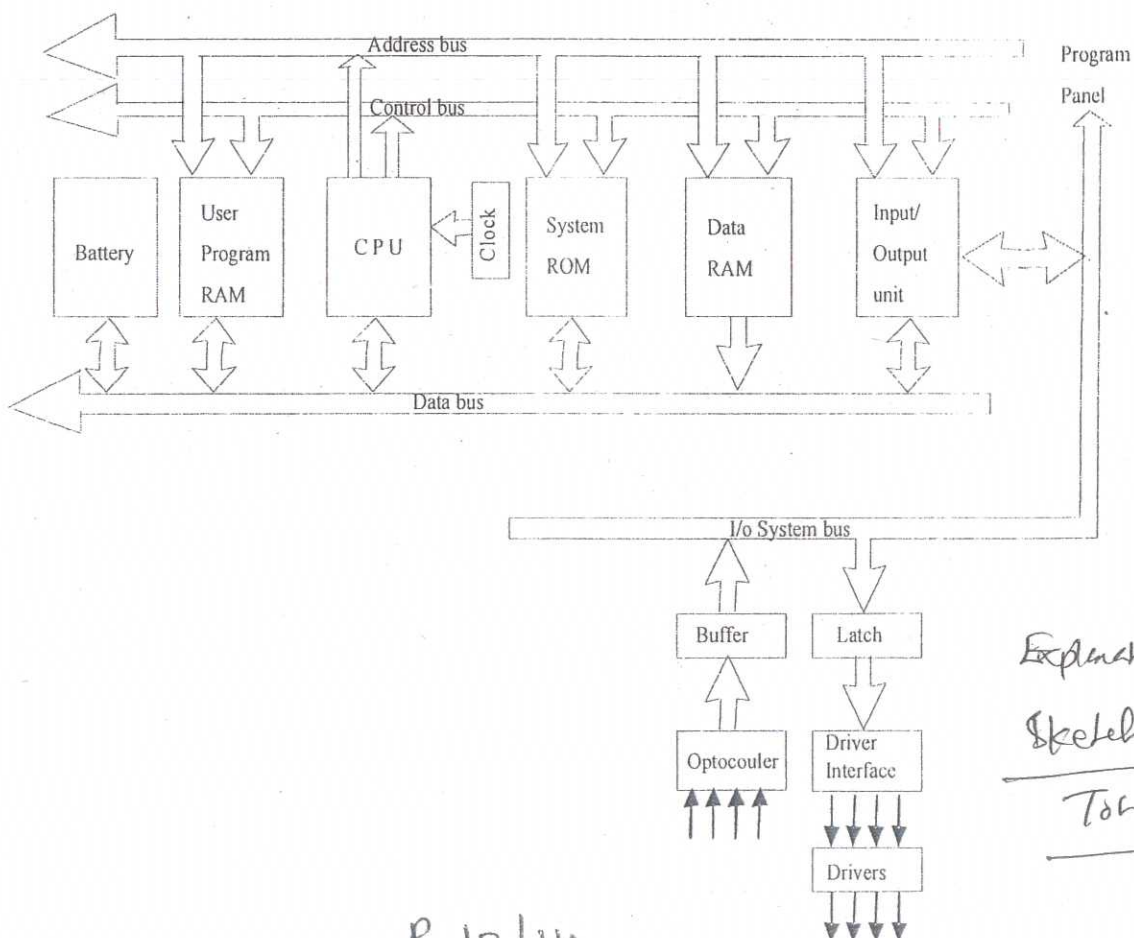

Explanation: 3 Marks

Sketch: 6 Marks

Total : 9 Marks

IX b)

MICRO CONTROLLER

The micro controller is the integration of a micro processor with memory location and timing/counter. It is also a single chip (or) Integrated Chip.

Characteristics :

1. Low cost
2. Small size
3. High reliable
4. Less power dissipates

2 marks

Advantages :

1. Limited amounts of ROM and RAM - These are widely used for embedded control systems.
2. In Microwave Ovens - Control the timing and cooking functions.
3. In Automobiles - Cruise control, anticlock braking ignition control, keyless entry, environment control, and air and fuel flow.

2 Marks

Disadvantages :

- (i) Micro controller of clock speeds are slower than those used for micro computers.
- (ii) Some of the micro controller may not have enough speed or memory to satisfy the needs of the application.

2 marks

X a)

Time: 6 marks

8.5.2 Bathroom Scales :

Consider the design of a simple weighing machine, i.e. bathroom scales. The main requirements are that person can stand on a platform and the weight of that person will be displayed on some form of readout. The weight should be given with reasonable speed and accuracy and be independent of where on the platform the person stands.

The following are the possible solutions

- (i) Parallel leaf springs arrangement
Rack and pinion arrangement and
- (ii) Use of microprocessor.

Two parallel leaf and Springs arrangement or (Rack and pinion arrangement):

To use the weight of the person on the platform to deflect an arrangement of two parallel leaf springs as shown in Fig. 8.4 with such an arrangement the deflection is virtually independent of where on the platform the person stands. The deflection can be transformed into movement of a pointer across a scale by using the arrangement shown in Fig. A rack-and pinion is used to transform the linear motion into a circular motion about a horizontal axis. This is then transformed into a rotation about a vertical axis, and hence movement of a pointer across a scale by means of a bevel gear.

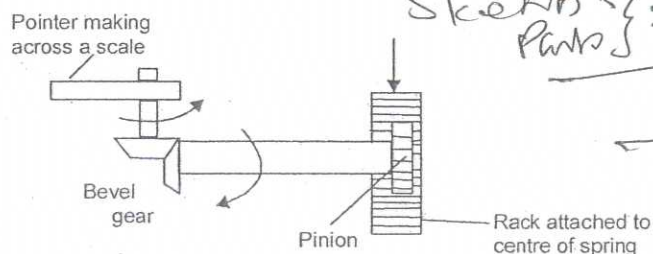
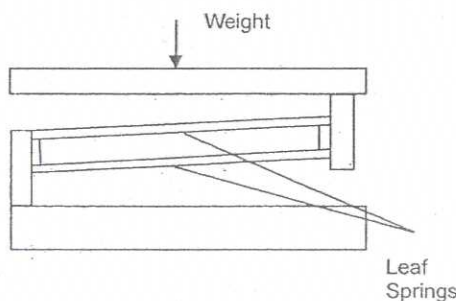

Explanation: 3 marks

Sketches: 6 Marks

Parts: 3 Marks

3 Marks

X b) Fault detection technique:

- i) Expected value checks.
- ii) Timing checks.
- iii) Reversal checks.
- iv) Parity and Error coding checks.
- v) Diagnostic checks.

Name (any 3)	3 Marks
Explan (any 4)	3 Marks

Explanation

Expected Value Checks :

Software errors are commonly detected by checking whether an expected value is obtained when a specific numerical input is used. If the expected value is not obtained then there is a fault.

Timing Checks :

This involves the use of checks that some function has been carried out within a specified time. These checks are commonly referred to as watch dog timers. For example, with a 'PLC', when an operation starts a timer is also started and if the operation is not completed within the specified time a fault is assumed to have occurred. The watch dog timer trips, sets off an alarm and closes down part or the entire plant.

Reversal Check :

Where there is a direct relationship between input and output values, the value of the output can be taken and the input which should have caused it computed. This can then be compared with the actual input.

Parity and Error Coding Checks :

This form of checking is commonly used for detecting memory and data transmission errors. Communication channels are frequently subject to interference which can affect data being transmitted. To detect whether data has been corrupted a parity bit is chosen to make the resulting number of 1s in the group either odd (odd parity) or even (even parity). If odd parity then the word can be checked after transmission to see if it is still odd. Other forms of checking involve codes added to transmitted data in order to detect corrupt bits.

Diagnostic Checks :

Diagnostic checks are used to test the behaviour of components in a system. Inputs are applied to a component and the outputs compared with those which should occur.

Total 6 marks