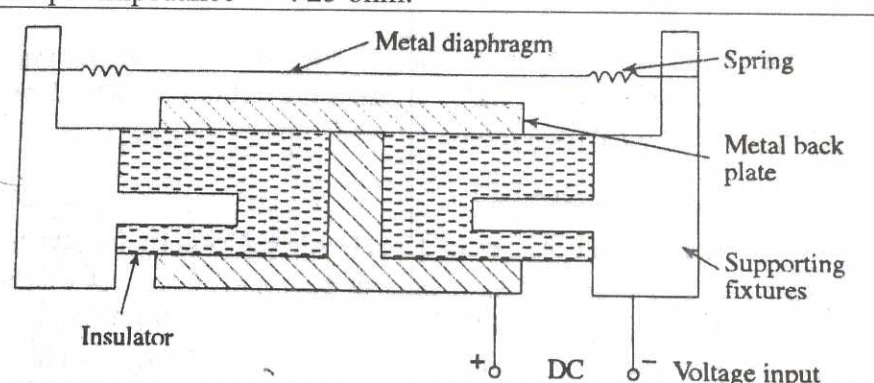

**SCHEME OF VALUATION**  
**(Scoring Indicators)**

Revision : 2015

Course Code: TED (15) – 6046

Course Title : TELEVISION ENGINEERING

Qst. No.	Scoring Indicators	Split up score	Sub Total	Total
<b>Part A</b>				
[I] 1	Dolby system is based on the principle of how human ear processes audio. By focusing on masking, eliminating and reducing the noise, Dolby system reduces the data required to produce high quality audio, but maintains the essential amount of data to ensure good fidelity. Dolby System provided surrounded sound system.	2	2	2
[I] 2	Width to height ratio of a picture frame is called Aspect ratio. Width is kept longer than height because: (i) Horizontal dimension of a scene is generally more than the vertical dimension. (ii) Retina has greater width than height.	2	2	2
[I] 3	MAC stands for Multiplexed Analog component signal, it uses interlaced scanning and the luminance and chrominance information for each line is being scanned and is transmitted simultaneously but in the interleaved form. MAC system the luminance and chrominance signals are multiplexed using TDM technique and send as separated in time domain and send as separate components this will eliminate the interference.	2	2	2
[I] 4	Component video signals contain three different types of information: <i>scan</i> , which tells displays exactly where video lines and frames begin and end; <i>luminance</i> , which specifies how bright each part of the image should be; and <i>chrominance</i> (red, green, blue), which controls the image's colour.	2	2	2
[I] 5	CAS stands for Conditional Access System, which is digital mode of transmitting TV channels through a set-top box (STB). The transmission signals are encrypted and viewers need to buy a STB to receive and decrypt the signal.	2	2	2
<b>Part B</b>				
[II] 1	Sensitivity : 30 micro volts (or 90dB below 1 volt) Signal to noise ratio : 30 dB. Frequency response : 60 Hz to 8000 Hz for $\pm 1$ dB. Distortion : Less than 5% Directivity : Omni directional (directivity angle $90^0$ in the front). Output impedance : 25 ohm.	6 x 1	6	6
[II] 2	 <p>Diaphragm of the microphone acts as one plate of the capacitor. The other plate, called back plate, is fixed. When sound pressure moves the diaphragm in, the capacitance increases, and when it moves out, the capacitance decreases. The change in capacitance results in change in voltage.</p>	Fig - 3 Exp-3	6	6

[II] 3	<p>(i) <u>Luminance</u>: This is the amount of light intensity as perceived by the eye regardless of the colour. In black and white pictures, better lighted parts have more luminance than the dark areas. In black and white pictures, better lighted parts have more luminance than the dark areas. Thus on a monochrome TV screen, dark red color will appear as black, yellow as white and a light blue color as grey.</p> <p>(ii) <u>Hue</u>: This is the predominant spectral colour of the received light. Thus the colour of any object is distinguished by its hue or tint. Different hues result from different wavelengths of spectral radiation and are perceived as such by the sets of cones in the retina.</p> <p>(iii) <u>Saturation</u>: This is the spectral purity of the colour light. Since single hue colours occur rarely alone, this indicates the amounts of other colours present. Thus saturation may be taken as an indication of how little the colour is diluted by white. A fully saturated colour has no white. The hue and saturation of a colour put together is known as chrominance.</p>	3x2	6	6
[II] 4	<p>In subtractive mixing, reflecting properties of pigments are used, which absorb all wavelengths but for their characteristic colour wavelengths. When pigments of two or more colours are mixed, they reflect wavelengths which are common to both. Since the pigments are not quite saturated (pure in colour) they reflect a fairly wide band of wavelengths.</p>	Fig - 3 Exp-3	6	6
[II] 5	<ol style="list-style-type: none"> <li>1. MPEG2 is the encoding methods for DVDs, while MPEG4 is the encoding methods of choice for portable devices, online use and it was developed for use with any device.</li> <li>2. MPEG2 encoded video files are much bigger compared to MPEG4.</li> <li>3. MPEG2 require a lot more bandwidth for streaming compared to MPEG4.</li> <li>4. MPEG4 is its ability to identify and deal with separate audio and video objects in the frame, which allows individual elements to be compressed more efficiently.</li> <li>5. MPEG2's compression is much simpler compared to MPEG4.</li> <li>6. MPEG4 providing higher quality for much lower bit rate compared to MPEG2.</li> <li>7. User controlled interactive sequences that include audio, video, text, 2D, 3D objects and animations are all part of the MPEG4 frame work</li> </ol>	6 x 1	6	6

[II] 6	<p>Cold cathode fluorescent lamps are used to illuminate traditional LCD TVs; the LEDs replace these lamps with hundreds of the smaller LEDs.</p> <p>There are two types of LED illumination one called edge lit which uses LEDs just around the perimeter of the screen and full array lighting which uses the LED's across the entire back of the screen.</p> <p>One of the advantages of the new LED TVs in addition to having a sharper picture and being thinner is that they are more energy efficient than traditionally illuminated LCD and plasma TVs.</p>	6	6	6
[II] 7	<p>In short, DTH refers to the reception of satellite signals on a TV with a personal dish in an individual home. The satellites that are used for this purpose is geostationary satellites. The satellites compress the signals digitally, encrypt them and then are beamed from high powered geostationary satellites. They are received by dishes that are given to the DTH consumers by DTH providers.</p> <p>For a DTH network to be transmitted and received, the following components are needed.</p> <ul style="list-style-type: none"> <li>• Broadcasting Centre</li> <li>• Satellites</li> <li>• Encoders</li> <li>• Multiplexers</li> <li>• Modulators</li> <li>• DTH receivers</li> </ul> <p>The broadcast centre is the main part of the whole system. It is from the broadcast station that the signals are sent to the satellites to be broadcasted. The broadcast station receives the signals from various program channels.</p> <p>The satellite receives the signal from the broadcast centre and compresses the signals and makes them suitable for re-transmission to the ground.</p> <p>The DTH providers give dish receivers for the viewers to receive the signal from the satellites. There may be one or multiple satellites that send the signals at the same time. The receiver receives the signal from them and is passed on to the Set Top Box [STB] receiver in the viewer's house.</p> <p>The STB receiver changes the signal in a form suitable for our television and then passes it on to our TV.</p>	6	6	6
<b>Part C</b>				
III (a)	<p>A compact disk contains record of digital audio signals in the form of pits of 1 <math>\mu\text{m}</math> depth and 0.5<math>\mu\text{m}</math> width but of variable length. Pitch of track is 1.6 <math>\mu\text{m}</math>. Recording is done on a resist master disk (RMD) with the help of powerful laser beam. The laser beam is modulated by digitized audio signal. The audio signal is sampled at the rate of 44.1 kHz. The quantum levels pertain to 16 bits. Thus the bits per second are 705600. To these bits are added bits for correction, controlling and modulating the signals. The digital input signal is so encoded that whenever 1 appears in the signal, it causes transition from ON to OFF and OFF to ON. These pulses are then made to modulate the laser beam in ON-OFF mode. When laser beam is ON, a pit is formed, and when OFF, a flat is formed. The laser beam is focused, and the sharply focused beam is incident on the master disc.</p>	Fig - 4 Exp -4	8	8

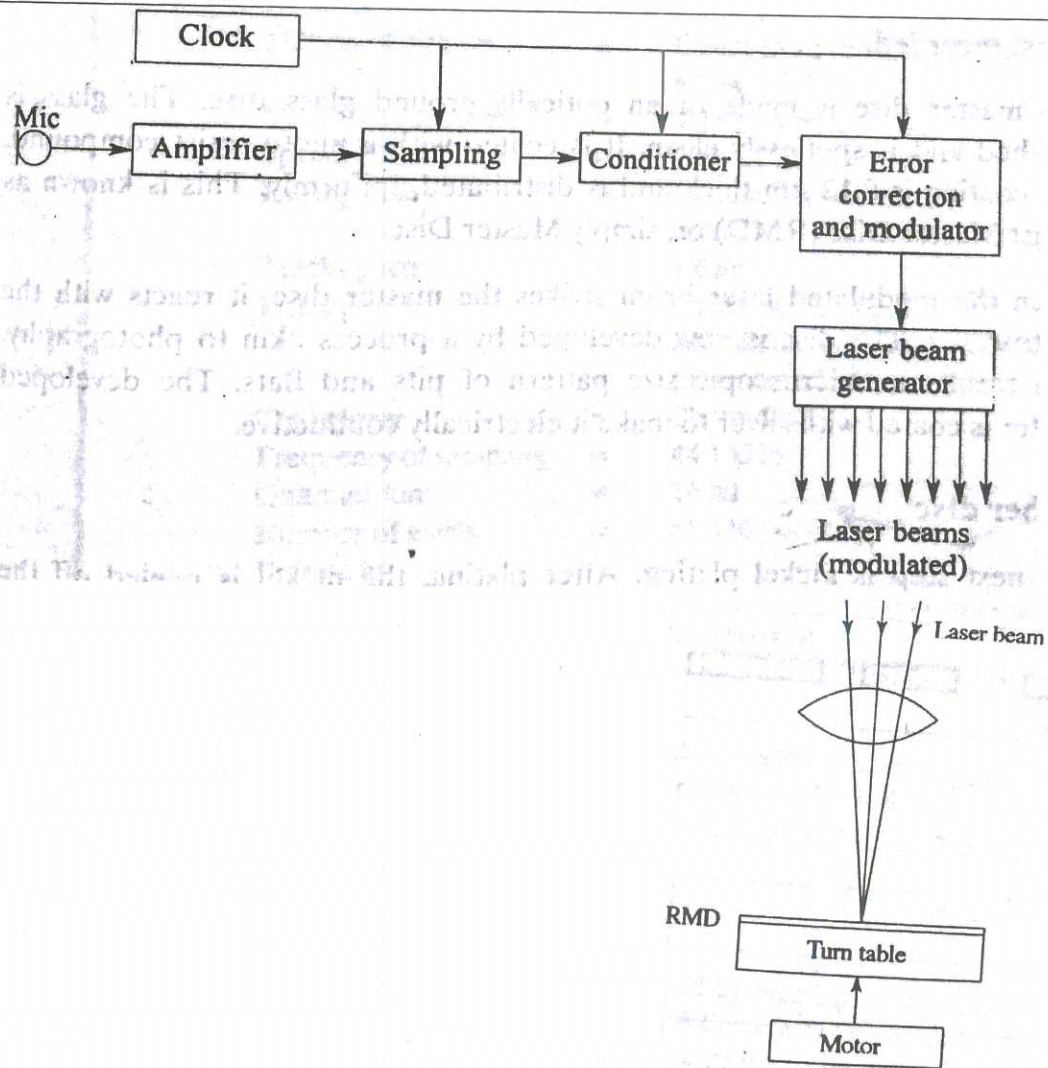

III (b)

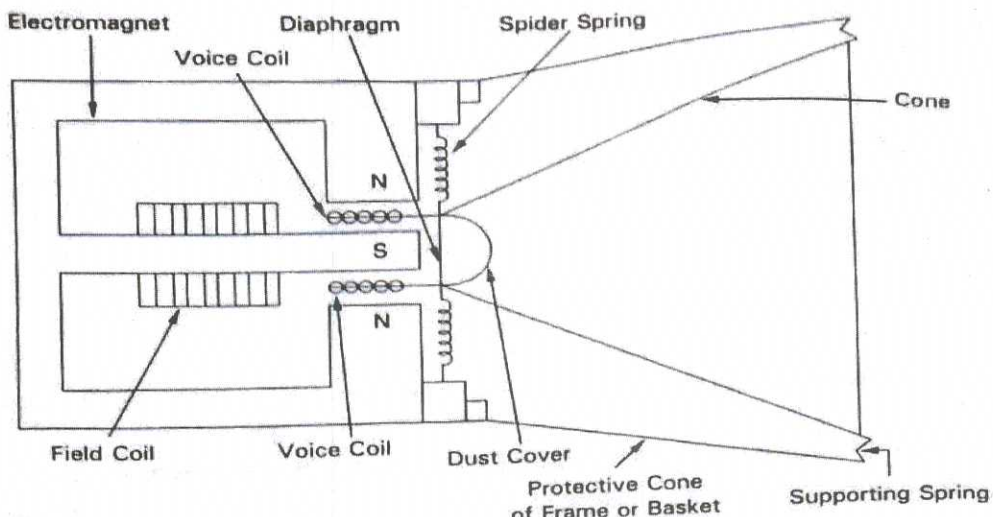
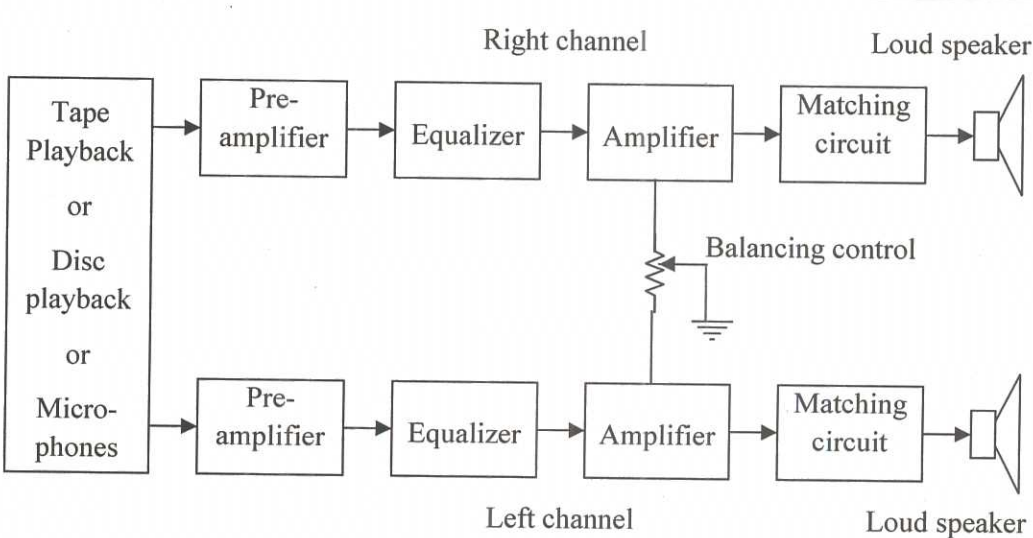
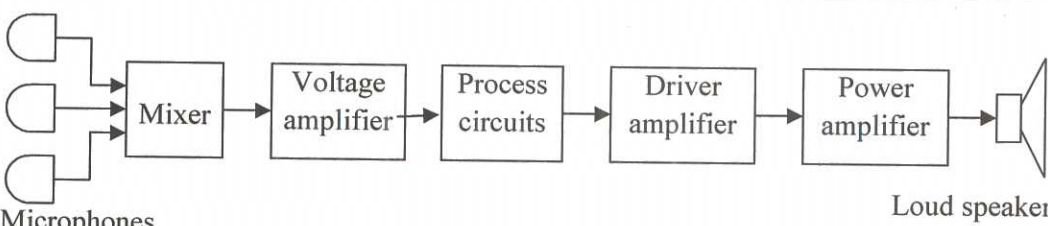

Fig - 4  
Exp- 3

To provide very strong magnetic field for high wattage speakers, electromagnet is used instead of permanent magnet. Loud speakers of more than 25 watt and up to a few hundred watt are of electro-dynamic type. The strong and steady magnetic field is produced by a large field coil wrapped around a core. The shape of the magnet is pot type with south pole in the centre and North pole in the periphery. The voice coil is wound on fibre or aluminum. It is placed in the annular gap.

<p>IV (a)</p>	 <p>High fidelity sound can be obtained from the recorded stereo tape or in live system from microphones. The stereo signal is fed to two independent amplification channels. The amplifier system consists of low noise high gain pre-amplifier, equalizer, well designed amplifiers giving flat frequency response and little distortion by using negative feedback circuit and then the matching transformer. Balancing control to give equal output for the same input. A Hi-Fi system should have a dynamic range of 60dB or more.</p>	<p>Fig-4 Exp-4</p>	<p>8</p>	<p>8</p>
<p>IV (b)</p>	 <p><i>Microphones:</i> It is a electrical transducer used to convert the sound waves into electrical signals  <i>Mixer:</i> Effectively isolate different channels from each other before feeding into the main amplifier.  <i>Voltage amplifier:</i> Amplifies the output of the mixer.  <i>Processing circuits:</i> Master gain control and tone controls.  <i>Driver amplifier:</i> It gives the voltage amplification  <i>Power amplifie:</i> It gives desired power amplification to the signal. It is push-pull type of circuit.</p>	<p>Fig - 4 Exp- 3</p>	<p>7</p>	<p>7</p>
<p>V (a)</p>	<p>Composite video signal consists –</p> <ul style="list-style-type: none"> <li>(i) Luminance (brightness) information</li> <li>(ii) Colour information (chroma signal)</li> <li>(iii) H and V- blanking pulses.</li> <li>(iv) H and V- sync pulses.</li> <li>(v) Colour burst signal</li> </ul> <p>A horizontal synchronizing pulse is needed at the end of each active line period whereas a vertical sync pulse is required after each field is scanned. The level of the video signal when the picture detail being transmitted corresponds to the maximum whiteness to be handled, is referred to as white level. This is fixed 10 to 12.5% of the</p>	<p>Fig-3 Exp-5</p>	<p>8</p>	<p>8</p>

maximum value of the signal while the black level corresponds to approximately 72%.

The sync pulses are added at 75% level called blanking level. The difference between black level and blanking level is known as Pedestal. The composite video signal modulates a video carrier in VHF/UHF band using amplitude modulation.

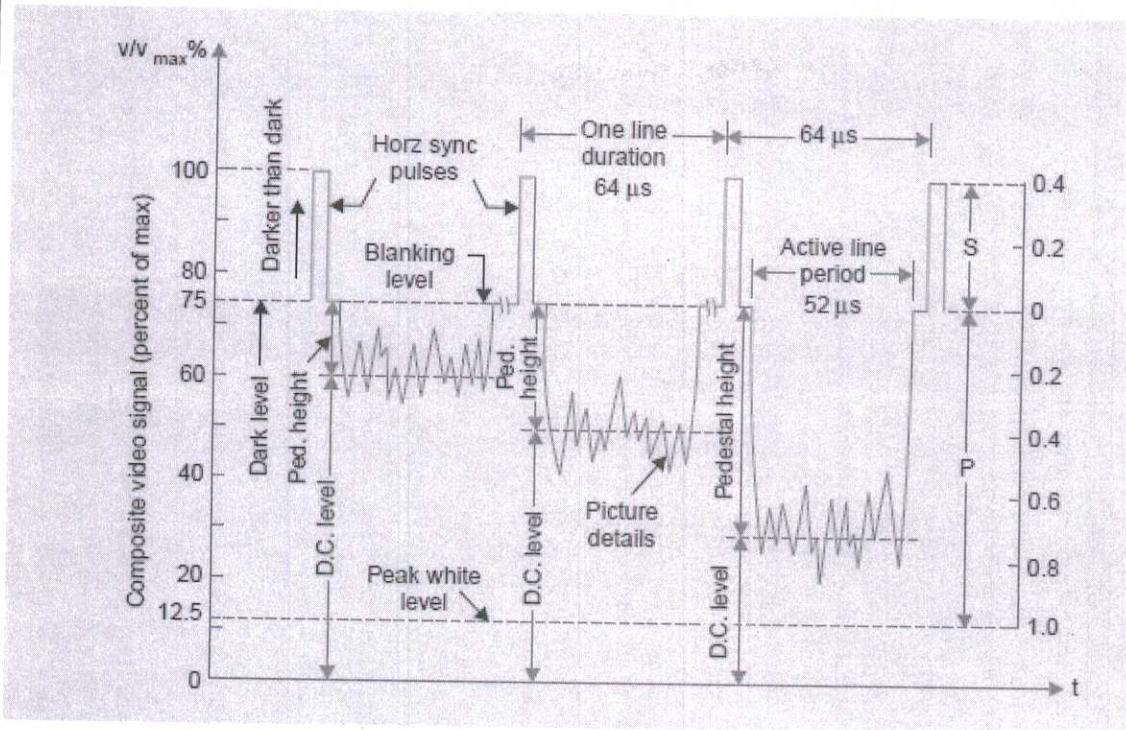

V (b)

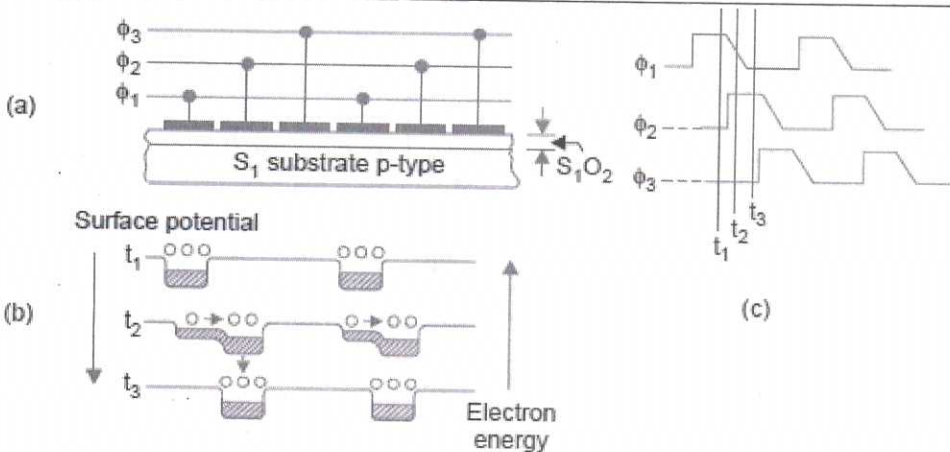

Fig - 3  
Exp- 4

7 7

The operation of solid state image scanners is based on the functioning of charge coupled devices (CCDs) which is a new concept in metal-oxide-semiconductor (MOS) circuitry. The CCD may be thought of to be a shift register formed by a string of very closely spaced MOS capacitors. It can store and transfer analog charge signals—either electrons or holes—that may be introduced electrically or optically. The chip consists P-type substrate which is covered with an insulator SiO<sub>2</sub>. Then the metallic gates are deposited on SiO<sub>2</sub>. Each gate creates one MOS capacitor thus a large number of MOS capacitor can be formed on entire surface of tube.

Now if the potential is applied to any of the gates, the holes in p-type substrate under that gate will be repelled away and a depletion region will be formed, this depletion region is known as potential wells. When light from the scene falls on the wells,

electrons are generated. Within it these electrons are attracts towards the gate and they are accumulated towards the surface. The number of electrons generated depends upon the intensity of light. As a result, the charges at the top of the substrate represents the optical image.

Charge Transfer: The charge of one element is transferred along the surface of silicon chip by applying a more +ve voltage to the adjacent electrodes or gate while reducing the voltage on it. The accumulation of charge carries under the first potential wells of two consecutive trios, where at instant  $t_1$  a potential  $\phi_1$  exists at the corresponding gate electrodes. In practice the charge transfer is effected by multiphase clock voltage pulses, which are applied to the gates in a suitable sequence. The manner in which the transition takes place from potential wells under  $\phi_1$  to those under  $\phi_2$ . A similar transfer moves charges from  $\phi_2$  to  $\phi_3$  and then from  $\phi_3$  to  $\phi_1$  under the influence of continuing clock pulses. Thus, after one complete clock cycle, the charge pattern moves one stage (three gates) to the right. The clocking sequence continues and the charge finally reaches the end of the array where it is collected to form the signal current.

VI (a)

The chroma and burst signals are amplified by the 1<sup>st</sup> chroma amplifier which is gain controlled with the voltage developed by the Automatic Chroma Control amplifier. The 2<sup>nd</sup> chroma amplifier incorporates colour saturation circuit. The delay line and addition and subtraction circuits separates the U and V signals. Burst phase discriminator is sensitive to burst pulse and is designed to detect any difference which might exist between the pase of burst pulse and that of reference oscillator. A second output from the gated burst preamplifier is converted to a dc voltage by a rectifier circuit. The colour killer is a half wave rectifying circuit which produces steady dc potential from the succession of burst pulses.

Fig-5  
Exp-3

8

8

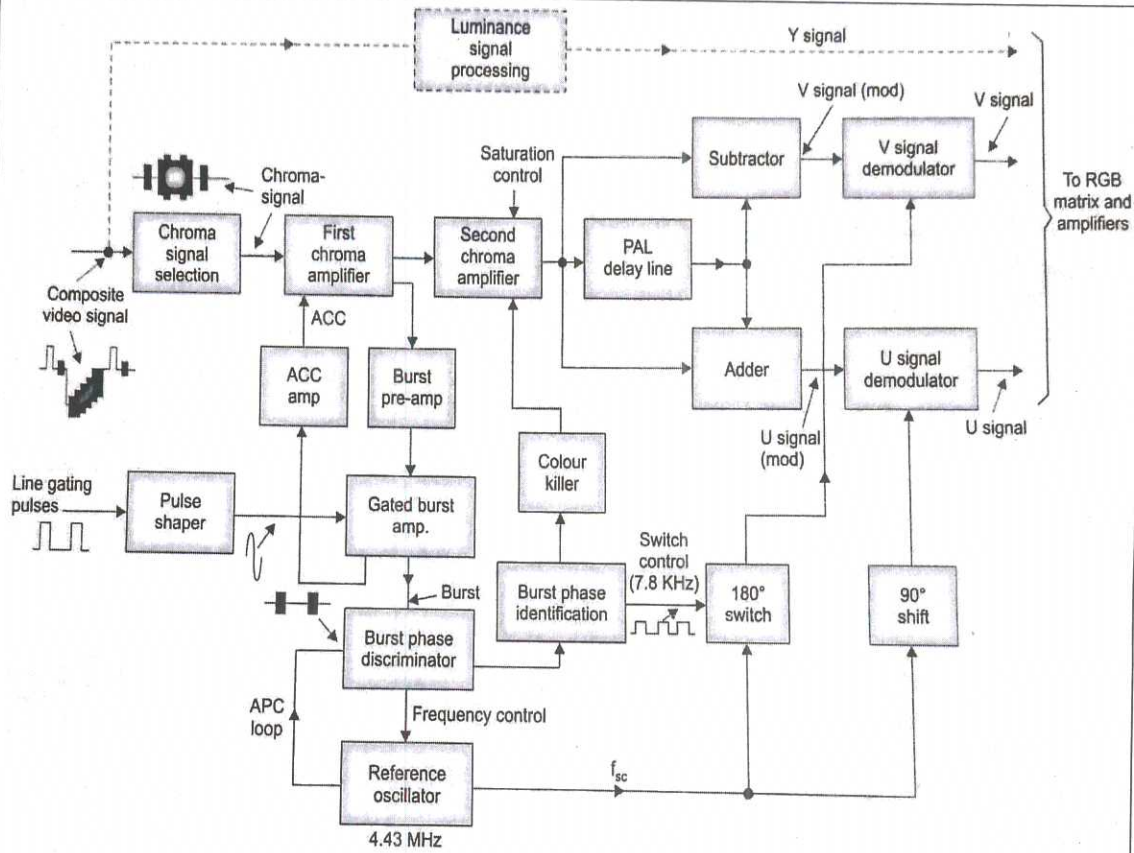

VI (b)

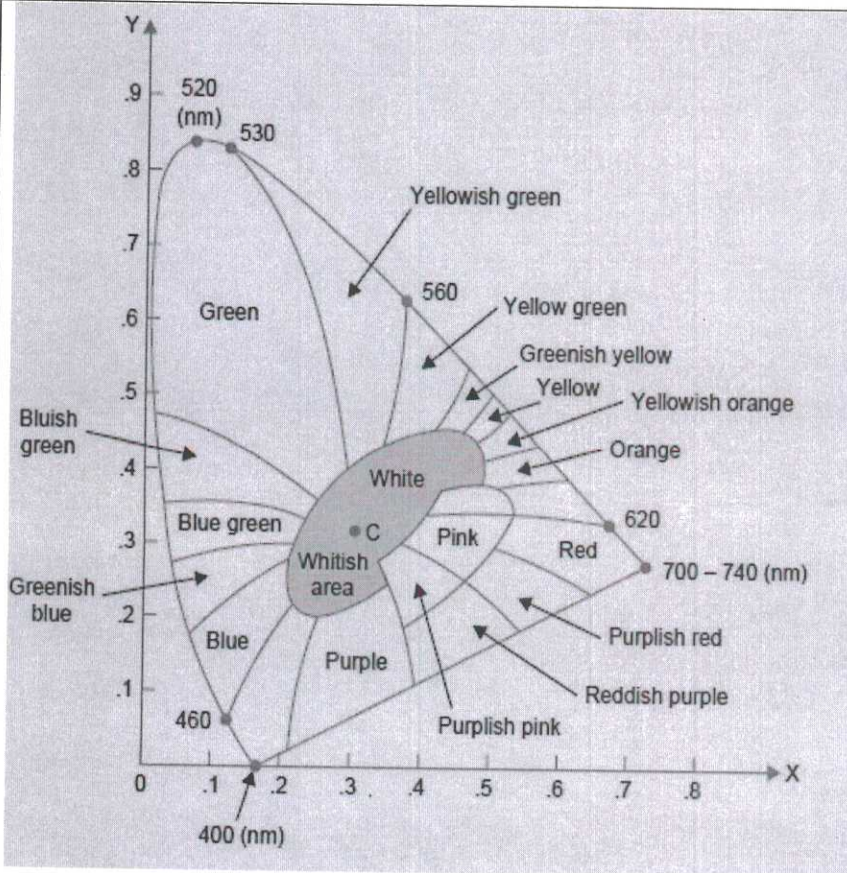

• Chromaticity diagram is a space coordinate representation of all the spectral colours

Fig - 4  
Exp- 3

7 7

and their mixtures.

- Fig. shown is a two dimensional representation of hue and saturation in the X-Y plane. If a three dimensional representation is drawn, the 'Z' axis will show relative brightness of the colour.
- Saturated pure spectral colors are represented along the perimeter of the curve.
- The corners representing the three primary colors—**red, green and blue.**
- As the central area of the triangular curve is approached, the colours become de-saturated representing mixing of colours or a white light.
- The white lies on the central point 'C' with coordinates  $x = 0.31$  and  $y = 0.32$ .
- The illuminant 'C' marked in figure represents a particular white light formed by combining hues.
- A practical advantage of the chromaticity diagram is that, it is possible to determine the result of additive mixing of any two or more colour lights by simple geometric construction.

VII (a)

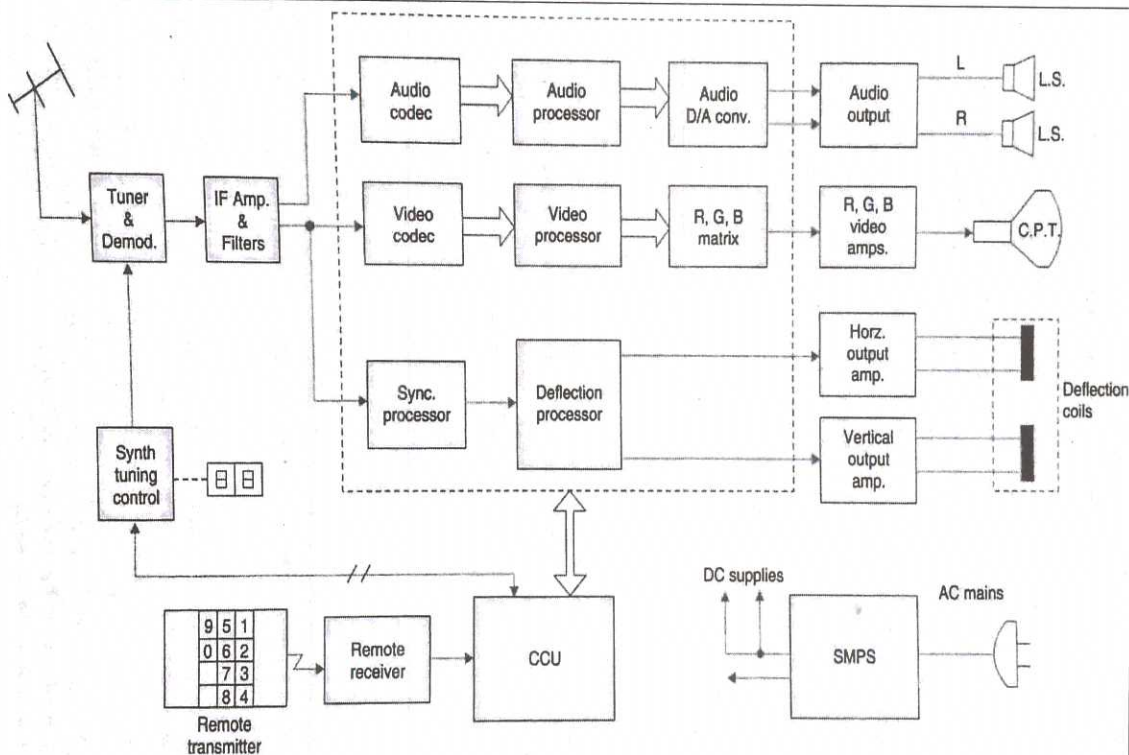

Fig-5  
Exp-3

8 8

*Video codec:* takes signal from the IF stage convert the analog composite video signal by its high speed flash A/D converter into an 8 bit digital signal.

*Video processor:* It takes the video codec output and separates it into two channels- luminance and chrominance.

*Deflection processing unit:* synchronises the vertical and horizontal sweep generators by counting the colour sub carrier and locking to it.

*Audio codec:* A/D converter.

*Audio processor:* Audio processor takes the signal from the converter and splits it into two channels.

*Central Control Unit (CCU):* A control computer that controls other chips and translates the user's instructions from an entry keyboard or from remote transmitter. The control computer also stores factory alignments programmed during manufacturing and feeds these to other chips, each time the set is turned on.

<p>VII (b)</p>	<p>It employs a single gun having three in-line cathodes. This simplifies constructional problems since only one electron gun assembly is to be accommodated. The three phosphor triads are arranged in vertical strips. Each strip is only a few thousandth of a centimetre wide. A metal aperture grille like mask is provided very close to the screen. It has one vertical slot for each phosphor triad. The grille is easy to manufacture and has greater electron transparency. The three beams are bent by an electrostatic lens system and appear to emerge from the same point in the lens assembly. Since the beams have a common focus plane a sharper image is obtained with good focus over the entire picture area. All this simplifies convergence problems and fewer adjustments are necessary.</p>	<p>Fig - 4 Exp- 3</p>	<p>7</p>	<p>7</p>
<p>VIII (a)</p>	<p><i>Data compression:</i> Data compression technique is used to reduce the average data rate to about 3 to 6 Mbps. Similarly audio compression is also done to reduce audio bit rate by eliminating soft sounds that are near to louds.</p> <p><i>Data encryption:</i> To prevent unauthorized reception of channels for which a special fee is to be paid, their video signals are encrypted before up linking by inserting, special data called keys, into the pulse train to disturb its sequence and content with the aim to prevent normal reproduction of pictures on the receiver screen.</p> <p><i>Data packets:</i> Besides video and audio signals, conditional information is also transmitted to the customer which includes conditional access data, PC compatible data and program guide. Before transmission all the data packets are time-multiplexed into serial data before further processing at the transmitting site.</p> <p><i>Clock system:</i> Clock pulses are generated by an electronic digital clock driven by a crystal controlled oscillator.</p>	<p>Fig-4 Exp-4</p>	<p>8</p>	<p>8</p>

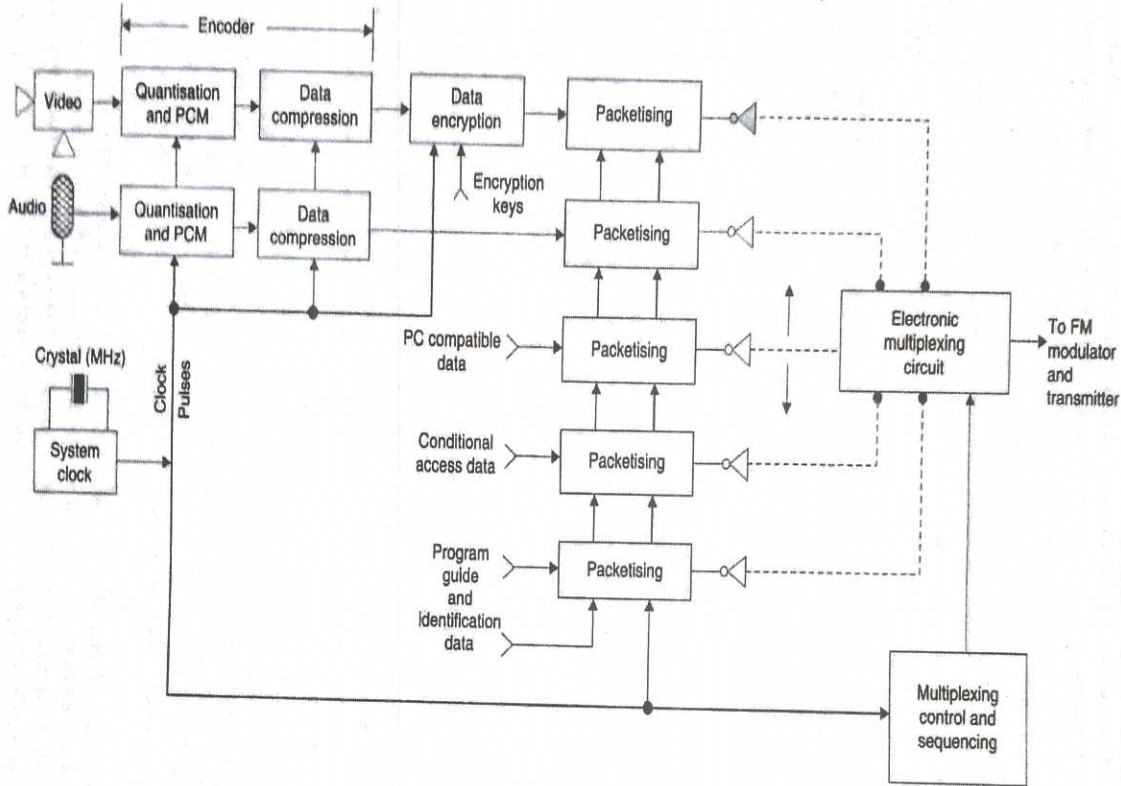

VIII (b)

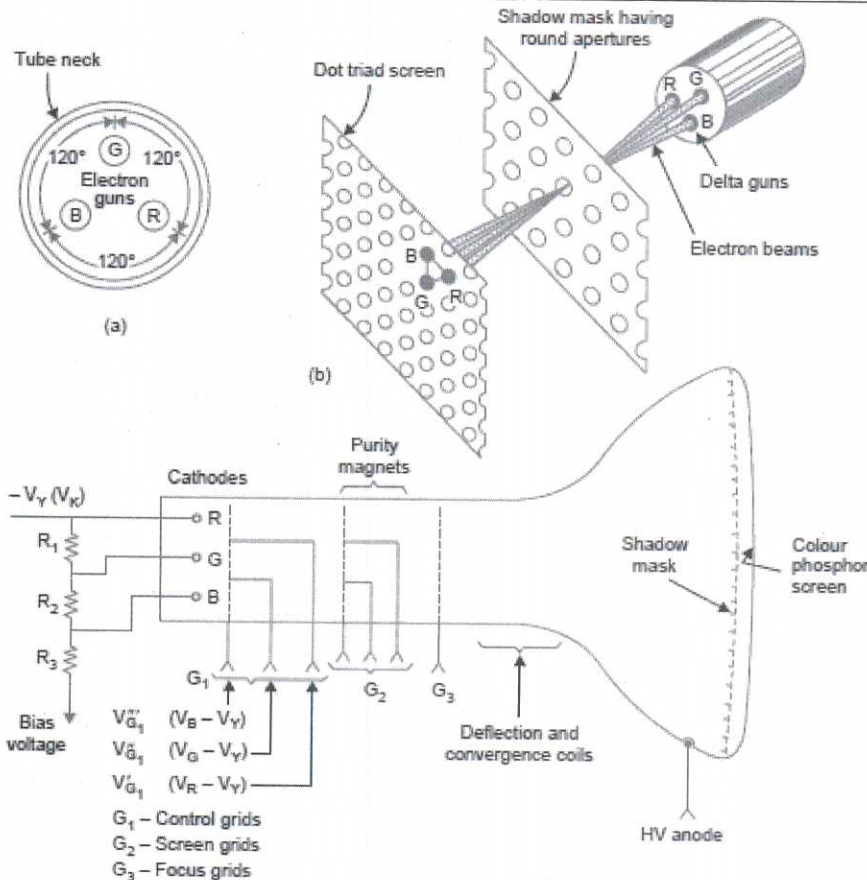

Fig - 4  
Exp- 3

7

7

This tube was first developed by the Radio Corporation of America (R.C.A.). It employs three separate, one for each phosphor. The guns are equally spaced at 120° interval with respect to each other and tilted inwards in relation to the axis of the tube. They form an equilateral triangular configuration. The tube employs a screen where

three colour phosphor dots are arranged in groups known as triads. Each phosphor dot corresponds to one of the three primary colours. The triads are repeated and depending on the size of the picture tube, approximately 1,000,000 such dots forming nearly 333,000 triads are deposited on the glass face plate. About one cm behind the tube screen is located a thin perforated metal sheet known as the shadow mask. The mask has one hole for every phosphor dot triad on the screen. The various holes are so oriented that electrons of the three beams on passing through any one hole will hit only the corresponding colour phosphor dots on the screen.

The overall colour seen is determined both by the intensity of each beam and the phosphors which are being bombarded. The demodulators in the receiver recover  $(B - Y)$  and  $(R - Y)$  video signals. The  $(G - Y)$  colour video signal is obtained from these two through a suitable matrix. The inverted luminance signal  $(- Y)$  is applied at the junction of the three cathodes. The signal voltages subtract from each other to develop control voltages for the three guns.

IX (a)

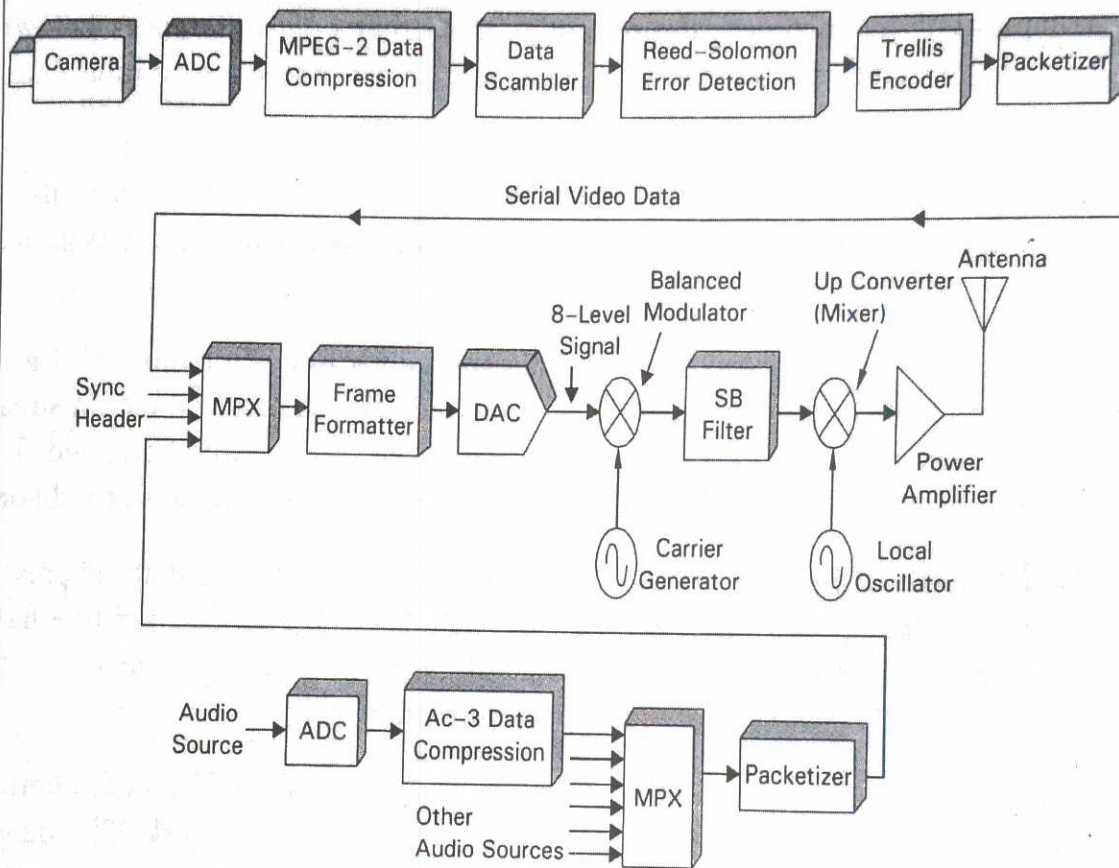

Fig-5  
Exp-3

8 8

In HDTV both the video and the audio signals must be digitized by A/D converters and transmitted serially to the receiver.

The video from the camera consists of the  $R$ ,  $G$ , and  $B$  signals that are converted to the luminance and chrominance signals. These are digitized by A/D converters. The luminance sampling rate is 14.3 MHz, and the chroma sampling rate is 7.15MHz.

The resulting signals are serialized and sent to a data compressor. The purpose of this device is to reduce the number of bits needed to represent the video data and therefore permit higher transmission rates in a limited-bandwidth channel.

The MPEG-2 data compressor processes the data according to an algorithm that effectively reduces any redundancy in the video signal. The algorithm also uses fewer bits to encode the color than to encode the brightness because the human eye is much more sensitive to brightness than to color.

Next the random serial signal is passed through a Reed-Solomon (RS) error detection and correction circuit. This circuit adds extra bits to the data stream so that transmission errors can be detected at the receiver and corrected. This ensures high reliability in signal transmission even under severe noise conditions.

Trellis encoder further modifies the data to permit error correction at the receiver. Each audio sample is converted to an 18-bit digital word. The audio information is time multiplexed and transmitted as a serial bit stream at a frequency of a data compression technique designated AC-3 is used to speed up audio transmission.

Next the video and audio data streams are packetized; i.e., they are converted to short blocks of data bytes that segment the video and audio signals. These packets are multiplexed along with some synchronizing signals to form the final signal to be transmitted. The result is a 188-bit packet containing both video and audio data plus 4 bytes of synchronizing bytes and a header.

The header identifies the number of the packet and its sequence as well as the video format. Next the packets are assembled into frames of data representing one frame of video. The complete frame consists of 626 packets transmitted sequentially. The final signal is sent to the modulator.

The modulation scheme used in HDTV is 8-VSB, or eight-level vestigial sideband, amplitude modulation. The carrier is suppressed, and only the upper sideband is transmitted.

The serial digital data is sent to a D/A converter where each sequential 3-bit group is converted to a discrete voltage level. The VSB signal can be created with a balanced modulator to eliminate the carrier and to generate the sidebands.

One sideband is removed by a filter or by using the phasing system. The modulated signal is up-converted by a mixer to the final transmission frequency, which is one of the standard.

IX (b)

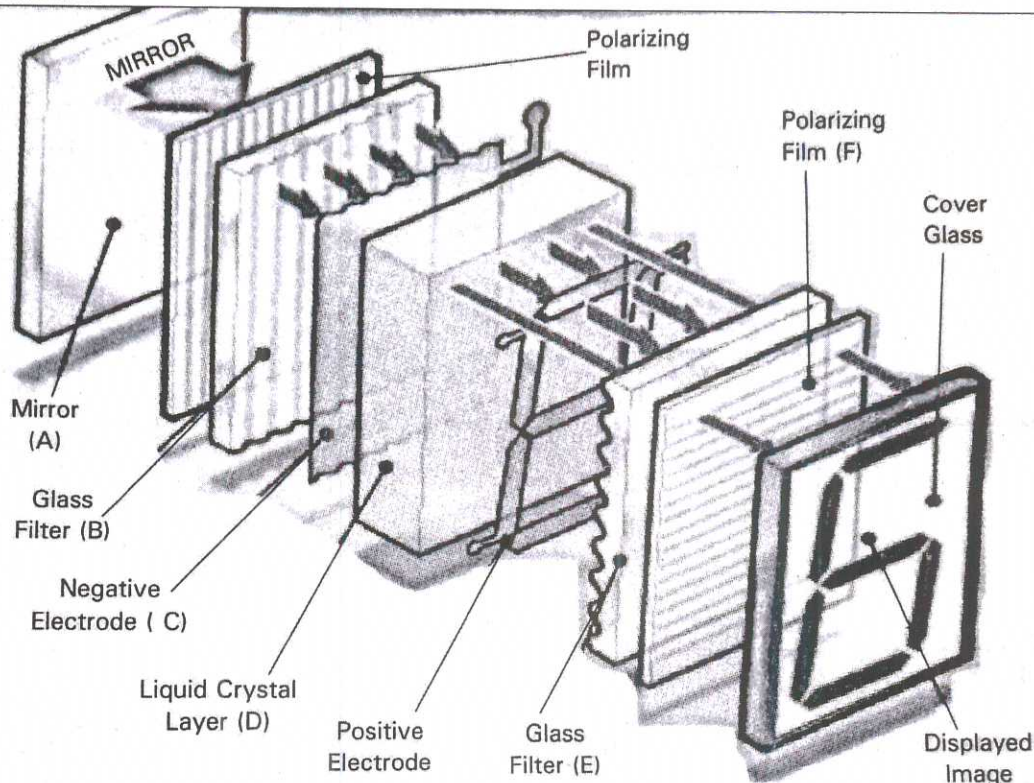

Fig - 3  
Exp- 4

7

7

**LCD TV** is a television display technology based on a liquid crystal display. LCD TVs consume much less power because they work on the principle of blocking light rather than emitting it.

- Consists of an array of tiny segments (called pixels) that can be manipulated to present information.
- Using polarization of lights to display objects.
- Use only ambient light to illuminate the display.

*Construction of Liquid Crystal Display*

- Two bounding plates (usually glass slides), each with a transparent conductive coating (such as indium tin oxide) that acts as an electrode;
- A polymer alignment layer: undergoes a rubbing process as grooves.
- Spacers to control the cell gap precisely;
- Two crossed polarizers (the polarizer and the analyzer);
- Polarizers are usually perpendicular to each other.

*Operating Principal* :The parallel arrangement of liquid crystal molecules along grooves, when coming into contact with grooved surface in a fixed direction, liquid crystal molecules line up parallel along the grooves. Molecules movement

*Offline (no voltage is applied)*

- Light travels through the spacing of the molecular arrangement.
- The light also "twists" as it passes through the twisted liquid crystals.
- Light bends 90 degrees as it follows the twist of the molecules.
- Polarized light pass through the analyzer(lower polarizer)

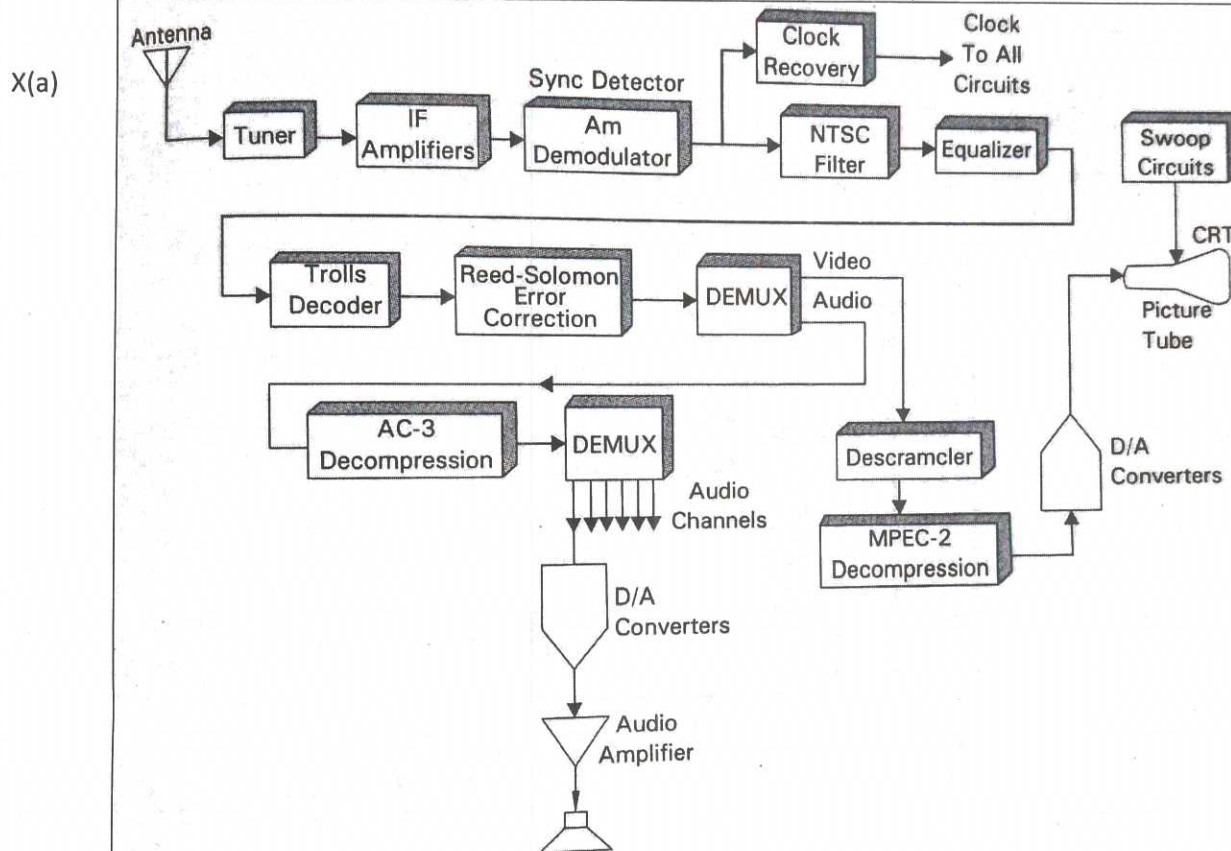

Fig-5  
Exp-3

8 8

An HDTV receiver picks up the composite signal and then demodulates and decodes the signal into the original video and audio information.

- The tuner and IF systems are similar to those in a standard TV receiver. From there the 8- VSB signal is demodulated (using asynchronous detector) into the original bit stream. A balanced modulator is used along with a carrier signal that is phase-locked to the pilot carrier to ensure accurate demodulation.
- □ A clock recovery circuit regenerates the clock signal that times all the remaining

digital operations. The signal then passes through an NTSC filter that is designed to filter out any one channel or adjacent channel interference from standard TV stations.

- □The signal is also passed through an equalizer circuit that adjusts the signal to correct for amplitude and phase variations encountered during transmission. The signals are de-multiplexed into the video and audio bit streams.
- □Next, the trellis decoder and RS decoder ensure that any received errors caused by noise are corrected. The signal is descrambled and decompressed. The video signal is then converted back to the digital signals that will drive the D/A converters that, in turn, drive the red, green, and blue electron guns in the CRT.
- □The audio signal is also de multiplexed and fed to AC-3 decoders. The resulting digital signals are fed to D/A converters that create the analog audio for each of the six audio channels.

X (b)

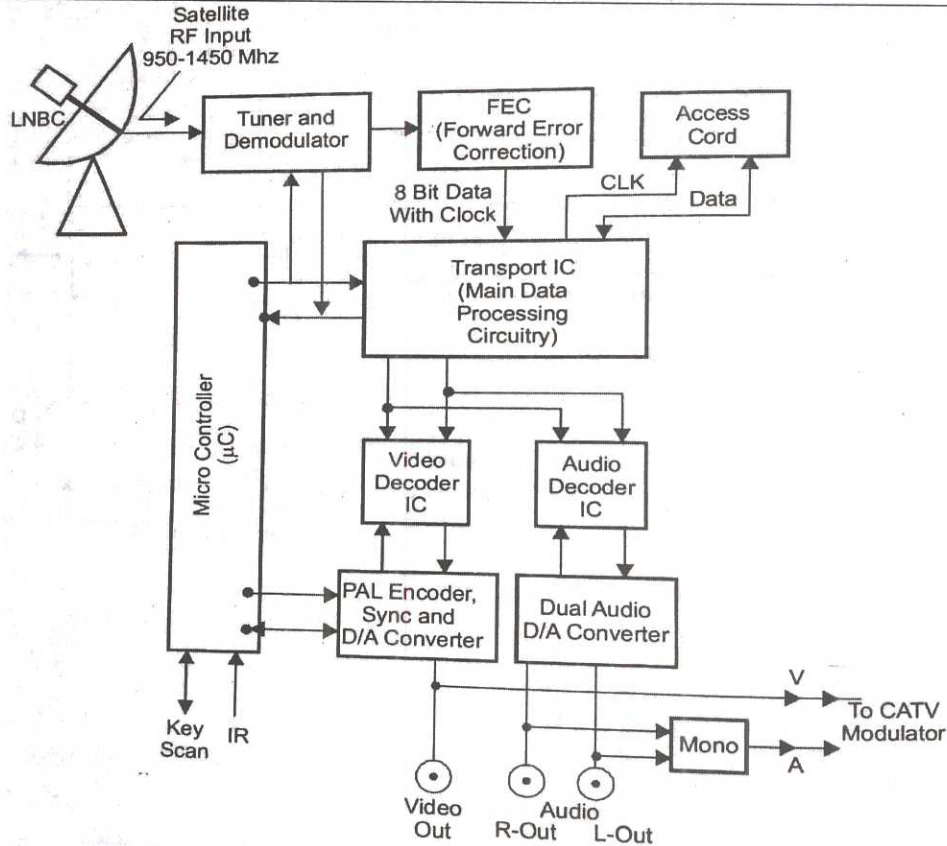

Fig - 4  
Exp- 3

7 7

*Tuner Demodulator:* The tuner is controlled by the micro controller on receipt of specific code pulses for each channel from the remote control unit. The separated channel signal is demodulated by the demodulator to obtain original digital data stream.

*Forward Error Correction:* This section reassembles the received data and corrects it if any error is detected.

*Transport IC:* It functions under the control of micro controller and isolates video, audio and associated data packets.

*Video and Audio Decoder:* Video and Audio Decoder IC separately decode the compressed video and audio data and send these to corresponding PAL video and audio encoders cum D/A converters.